

# 9200 and 74712 Seismoprobe Velocity Transducers

## Datasheet

Bently Nevada Machinery Condition Monitoring

141626 Rev. N



### Description

Bently Nevada Seismoprobe Velocity Transducer Systems are designed to measure absolute (relative to free space) bearing housing, casing, or structural vibration. The two-wire systems consist of a transducer and appropriate cable.

The Seismoprobe family of velocity transducers is a two-wire design that uses moving-coil technology. It provides a voltage output directly proportional to the transducer's vibration velocity.

Moving-coil transducers are less sensitive to impact or impulsive excitation than solid-state velocity transducers, which are inherently accelerometers with embedded integration electronics.

Moving-coil transducers are less sensitive to impact or impulsive excitation and can represent a good choice for certain applications. Because they don't require external power, they are convenient for portable measurement applications.



For most installations, Bently Nevada's Velomitor family of velocity transducers, which incorporate solid-state technology, provide improved performance and ruggedness for casing velocity measurement applications.



## Available Types

Two types of Seismoprobe Velocity Transducer are available:

- 9200: The 9200 is a two-wire transducer suitable for continuous monitoring or for periodic measurements in conjunction with test or diagnostic instruments. When ordered with the integral cable option, the 9200 has excellent resistance to corrosive environments without need of additional protection.
- 74712: The 74712 is a high temperature version of the 9200.

Interconnect cables are available for connecting the 9200 and 74712 transducers to other instruments. These cables are available in various lengths with or without stainless steel armor.

When ordering the 9200 and 74712 Seismoprobe Velocity Transducers, expect approximately a six (6) week lead time. That lead time can vary based on component availability and configuration. Contact your local Bently Nevada representative for projected lead times for your specific order.

## Measuring Housings for Transducer Placement

If you are measuring a machine housing to determine where to place transducers, consider the types of measurements you want to obtain. Most common machine malfunctions like imbalance or misalignment originate at the rotor and cause a change—usually an increase—in rotor vibration.



If you integrate the 330500 Velomitor output to measure displacement, electrical noise from interference and the transducer circuit can be amplified. The noise can degrade performance of 330500 transducers and produce inaccurate displacement data.

To obtain high quality data, plan on locating the transducer in a location where it can best detect machine



vibration through the bearing housing or machine casing. Select a location, grounding, and shielding that maximizes amplitude and frequency response and lessens data that doesn't represent actual machine vibration.

Bently Nevada provides engineering services to determine the optimum location to place transducers. We also can install transducers if needed. For assistance, contact your local customer care representative or **Bently.com**.

## Specifications

Specifications are at approximately +22°C (+72°F) with 25 mm/s (1 in/s) of machine casing vibration at 100 Hz (6000 cpm) with a 10 kΩ load unless otherwise specified.

### Electrical

Sensitivity	20 mV/mm/s (500 mV/in/s), ±5% when properly terminated and oriented at the angle of calibration.
Calibration Load	10 kΩ Terminal "A" to "B" Output taken across pins "A" and "B"
Sensitivity Temperature Coefficient	0.2%/°C
Frequency Response - <a href="#">See Theoretical Velocity Seismoprobe Frequency Response on page 10.</a>	4.5 to 1000 Hz (270 to 60,000 CPM); +0, -3dB typical. 10 to 1000 Hz (600 to 60,000 CAM); +0, -3dB typical. 15 to 1000 Hz (900 to 60,000 CPM); +0, -3dB typical.
Frequency response	From minimum operating frequency (see ordering information) to 1 kHz (60,000 cpm); +0, -3dB typical. Please contact Bently Nevada LLC. for detailed calibration data.
Dynamic operating range	2.54 mm (0.100 in) peak to peak maximum displacement.
Velocity Range	25 mm/s (1 in/s) (at +22 °C of casing vibration at 100 Hz with a 10 kΩ load.
Coil Resistance	1.25 kΩ ±5%
Locked Coil	125 mH, Typical

Inductance	
Amplitude Linearity	±5% from 0.01 to 5.0 in/s (0.254 to 127 mm/s) at 100Hz (6000CPM)
Shock resistance	Withstands 50 g peak maximum acceleration along non-sensitive axis.
Transverse sensitivity	±10% maximum of the sensitive axis sensitivity at 100 Hz and 1.0 in/s (2.54 cm/s)
Polarity of output signal	Pin A goes positive with respect to Pin B when the transducer case velocity is towards the connector.
Lead wire length	305 meters (1,000 feet) maximum between Seismoprobe Velocity Transducer and 3300 or 3500 Monitor. Consult manual for frequency roll-off at longer lengths.

### Environmental Limits

Operating and Storage Temperature:	9200: -29°C to +121°C (-20°F to +250°F). 74712: -29°C to +204°C (-20°F to +400°F):.
Environment	Dust and moisture resistant.  Note: Contact your Sales Professional regarding transducer operation in a radiation environment.
Relative Humidity	To 95%, noncondensing. 100%, non-submerged, when ordered with integral cable.

## Mechanical

Case and Adapter Material	Anodized aluminum A204
Gasket Material	9200: Neoprene 74712: Silicone

### Connector Material

Top and Side Mount Options	Cadmium-plated aluminum, neoprene, and silver-plated copper
Terminal Block Option	Polyphenylene Sulfide with nickel-plated copper contacts.

### Mounting Torque

½-20, ¼-20, ¼-28, 5/8-18, or M10x1 mounting base options:	5.6 Nm (50 in lb)
8-32 threaded studs	1.41 Nm (12.5 in lb)

## Physical

Height	102 mm (4 in) typical (depending on connector option).
Diameter	41 mm (1.6 in) typical.
Weight	9200 = 300 grams (10.5 ounces) typical. 74712 = 480 grams (17 ounces) typical.
Seismoprobe Velocity Transducer orientation	All Seismoprobe Velocity Transducers are specified for mounting orientation, <a href="#">see "Graphs and Figures" on page 1.</a>

## Compliance and Certifications

### FCC

This device complies with part 15 of the FCC Rules. Operation is subject to the following two conditions:

- This device may not cause harmful interference.
- This device must accept any interference received, including interference that may cause undesired operation.

### EMC

EN 61326-1

EMC Directive 2014/30/EU

### RoHS

RoHS Directive 2011/65/EU

### ATEX (where the applicable dash option has been ordered)

EN 60079-0

EN 60079-11

EN 60079-15

ATEX Directive 2014/34/EU

## Hazardous Area Approvals

### ATEX/IECEx

#### 74712 and 9200


---


 II 1 G Ex ia IIC T6 Ga  
II 3 G Ex nL IIC T6 Gc

T6 @ Ta = -20°C to +40°C

---

## Ordering Information

 For the detailed listing of country and product specific approvals, refer to the Approvals Quick Reference Guide (document 108M1756) at Bently.com.

 An isolated base ('06' thru '09', or '11', '12' in Mounting Base Option) is required when '04' Agency Approval Option is selected.

## Two-wire Transducer

### 9200 - AA-BB-CC-DD

#### A: Transducer Mounting Angle/Minimum Operating Frequency Option

<b>01</b>	0 ±2.5, 4.5 Hz (270 cpm)
<b>02</b>	45 ±2.5, 4.5 Hz (270 cpm)
<b>03</b>	90 ±2.5, 4.5 Hz (270 cpm)
<b>06</b>	0 ±100, 10 Hz (600 cpm)
<b>09</b>	0 ±180, 15 Hz (900 cpm)

#### B: Connector/Cable Option

<b>01</b>	Top Mount (no cable)
<b>02</b>	Side Mount (no cable)
<b>05</b>	Terminal block top mount (no cable)

#### 10 through 50

Integral hardline cable (see Figure 7 for example). Option number corresponds to cable length in feet. Standard cable lengths are shown below. Other cable lengths between 7 feet and 50 feet may be available through custom products. When ordering for hazardous area

<b>10</b>	10 feet (3.0 metres)
<b>15</b>	15 feet (4.6 metres)

<b>22</b>	22 feet (6.7 metres)
<b>32</b>	32 feet (9.8 metres)
<b>50</b>	50 feet (15.2 metres)

#### C: Mounting Base Option

<b>01</b>	Circular; 1/4-in 20 UNC stud
<b>02</b>	Circular; 1/4-in 28 UNF stud
<b>03</b>	Rectangular flange
<b>04</b>	Circular; with three 8-32 threaded studs on a 44 mm (1.75 in) diameter bolt circle
<b>05</b>	No base; 1/2-in 20 UNF-3A stud
<b>06</b>	Isolated circular 1/4-in 20 UNC stud
<b>07</b>	Isolated circular 1/4-in 28 UNF stud
<b>08</b>	Isolated rectangular flange
<b>09</b>	Isolated circular 5/8-in 18 UNF stud
<b>10</b>	Circular; M10X1 stud
<b>11</b>	Isolated circular M10X1
<b>12</b>	Isolated circular 1/2-in 20 UNF-2A

#### D: Agency Approval Option

<b>00</b>	No Approvals
<b>01</b>	CSA
<b>04</b>	ATEX/IECEX

## High-temperature Two-wire Transducer

### 74712 - AA-BB-CC-DD

#### A: Transducer Mounting Angle/Minimum Operating Frequency Option

<b>01</b>	0 ±2.5, 4.5 Hz (270 cpm)
<b>02</b>	45 ±2.5, 4.5 Hz (270 cpm)
<b>03</b>	90 ±2.5, 4.5 Hz (270 cpm)
<b>06</b>	0 ±100, 10 Hz (600 cpm)
<b>07</b>	0 ±180, 15 Hz (900 cpm)

#### B: Mounting Base Option

<b>01</b>	Circular; 1/4-in 20 UNC stud
<b>02</b>	Circular; 1/4-in 28 UNF stud
<b>03</b>	Rectangular flange
<b>04</b>	Circular; with three 8-32 threaded studs on a 44 mm (1.75 in) diameter bolt circle
<b>05</b>	No base; 1/2-in 20 UNF-3A stud
<b>06</b>	Isolated circular 1/4-in 20 UNC stud
<b>07</b>	Isolated circular 1/4-in 28 UNF stud
<b>08</b>	Isolated rectangular flange
<b>09</b>	Isolated circular 5/8-in 18 UNF stud
<b>10</b>	Circular; M10X1 stud
<b>11</b>	Isolated circular M10X1
<b>12</b>	Isolated circular 1/2-in 20 UNF-2A

#### C: Connector Option

<b>02</b>	Top Mount
<b>03</b>	Terminal block top mount
<b>04</b>	Side mount

#### D: Agency Approval Option

<b>00</b>	No Approvals
<b>01</b>	CSA
<b>04</b>	ATEX/IECEX

## Interconnection Cables

The standard cable lengths below are available. You can order custom cable lengths in increments of one foot at additional cost. Some cables have a minimum and maximum length. For details, see each part description below.

### Standard Cable Lengths

Feet	Meters (approximate)
6 ft	1.8 m
8 ft	2.4 m
10 ft	3.0 m
12 ft	3.6 m
15 ft	4.5 m
17 ft	5.0 m
20 ft	6.0 m
25 ft	7.6 m
30 ft	9.0 m
33 ft	10.0 m
50 ft	15.2 m
99 ft	30.0 m

## Cable Part Numbers

Part Number	Description
-------------	-------------



NOTE: Use 'NN' in these part numbers to specify the length (in feet) of the cable you want to order.

### Standard Cables

9571-NN	<p>2-conductor twisted, shielded 22 AWG (0.5 mm<sup>2</sup>) cable with 2-socket moisture-resistant female connector at one end, terminal lugs at the other end. (Used with monitors or vibration data collectors).</p> <p>Cable operating temperature is -50°C to 120°C.</p> <p>Minimum length of 2.0 ft (0.6 m); maximum length of 99 ft (30 m).</p>
84661-NN	<p>2-conductor twisted, shielded 22 AWG (0.5 mm<sup>2</sup>) armored cable with 2-socket moisture-resistant female connector at one end, terminal lugs at the other end. (Used with monitors or vibration data collectors).</p> <p>Cable operating temperature is -50°C to 120°C.</p> <p>Minimum length of 3.0 ft (0.9 m); maximum length of 99 ft (30 m).</p>
9755-NN	<p>2-wire shielded 22 AWG (0.5 mm<sup>2</sup>) cable with 2-pin female connectors at each end. (Connects 9200 or 74712 Seismoprobe Velocity Transducers to Bently Nevada test kits).</p> <p>Cable operating temperature is -70°C to 150°C.</p> <p>Minimum length of 1.0 ft (0.3 m); maximum length of 99 ft (30 m).</p>

Part Number	Description
83968-NN	<p>2-wire straight cable with 2-pin female connector at one end and coaxial connector in the other end (used with instruments with BNC connector input jacks).</p> <p>Minimum length of 2.0 ft (0.6 m); maximum length of 99 ft (30 m).</p>

### High-Temperature Cables

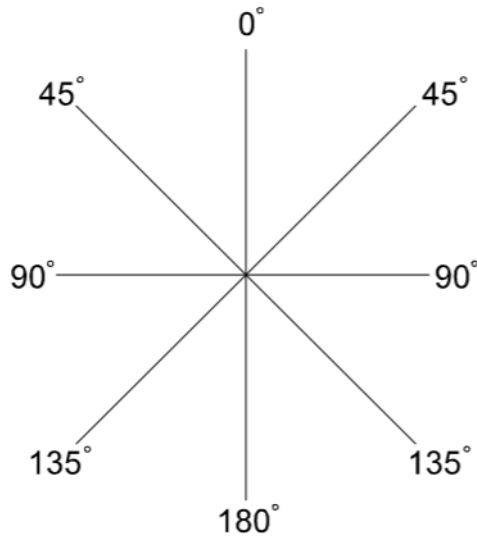
84508-NN	<p>2-wire shielded 22 AWG (0.5 mm<sup>2</sup>) cable with terminal lugs at each end.</p> <p>Minimum length of 1.0 ft (0.3 m); maximum length of 99 ft (30 m).</p>
84509-NN	<p>2-wire shielded 22 AWG (0.5 mm<sup>2</sup>) armored cable with terminal lugs at each end.</p> <p>Minimum length of 3.0 ft (0.9 m); maximum length of 70 ft (21 m).</p>
84660-NN	<p>2-wire shielded 22 AWG (0.5 mm<sup>2</sup>) cable with 2-socket female connector at one end, terminal lugs at the other end.</p> <p>Minimum length of 3.0 ft (0.9 m); maximum length of 99 ft (30 m).</p>
84510-NN	<p>2-wire shielded 22 AWG (0.5 mm<sup>2</sup>) armored cable with 2-socket female connector at one end, terminal lugs at the other end.</p> <p>Minimum length of 3.0 ft (0.9 m); maximum length of 70 ft (21 m).</p>
87143-NN	<p>2-wire shielded 18 AWG (1.0 mm<sup>2</sup>) cable with terminal lugs at each end. Withstands 200 °C (392 °F).</p> <p>Minimum length of 3.0 ft (0.9 m); maximum length of 99 ft (30 m).</p>



## Accessories

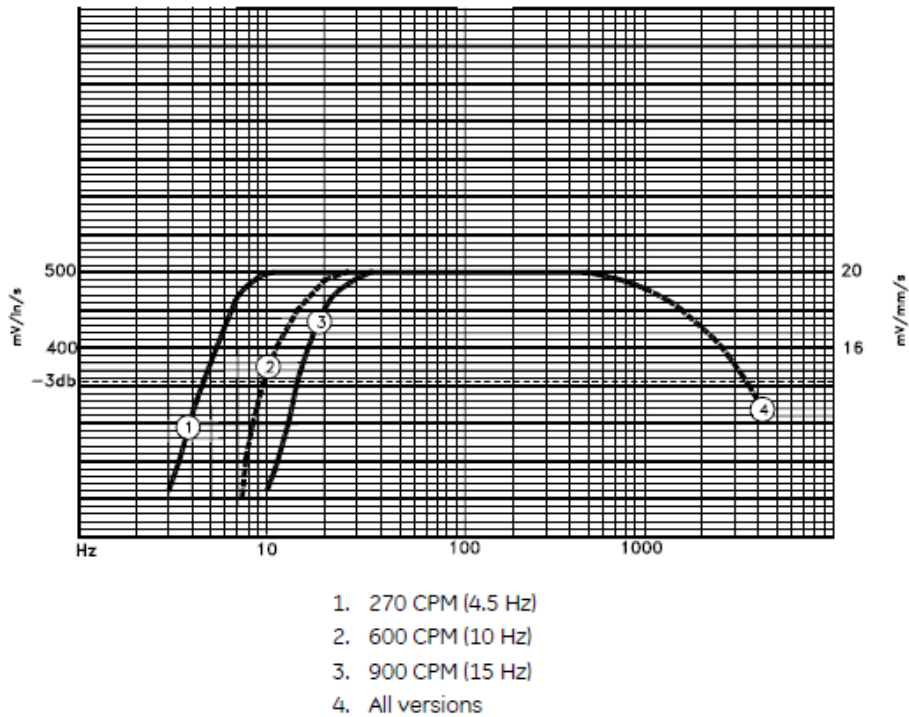
Part number	Description
46000-01	Magnetic Base for portable mounting of Seismoprobe Velocity Transducers.
46122-01	Quick connect for semi-permanent mounting of Seismoprobe Velocity Transducers.
02173006	Bulk cable; 2-conductor, twisted, shielded. 18 AWG (1.0 mm <sup>2</sup> ) cable without connectors or terminal lugs. Specify number of feet. Withstands +200°C (+392°F).
00531061	Mating connector for 9200 and 74712 Seismoprobe Velocity Transducers.
00530574	Cable Mounting Clamp

## Graphs and Figures

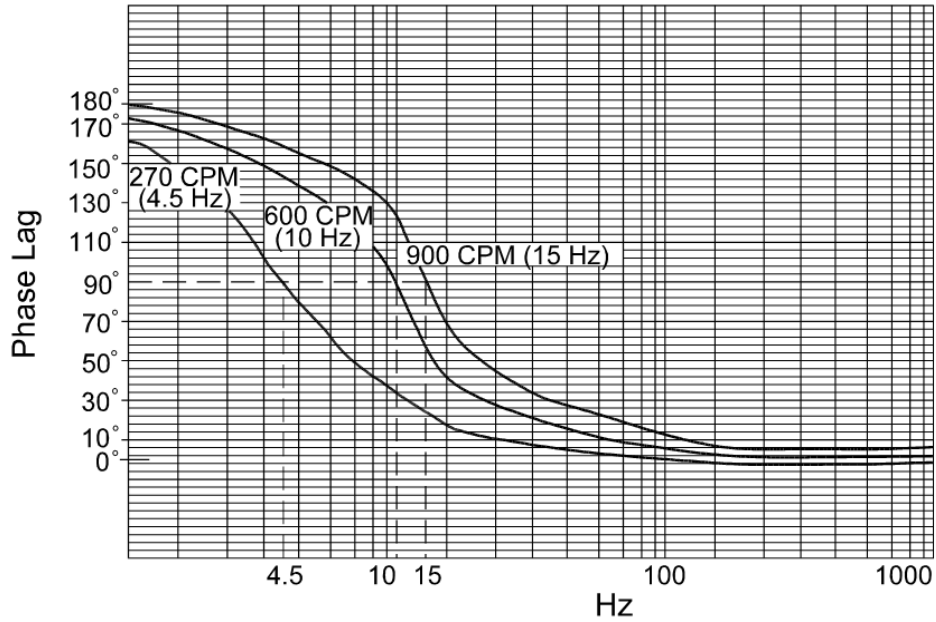


**Figure 1: Seismoprobe Orientation**

All Seismoprobe Velocity Transducers are specified for the mounting orientations shown here. 0° is vertical, as viewed from driver end of the monitored machine.



**Figure 2: Theoretical Velocity Seismoprobe Frequency Response**

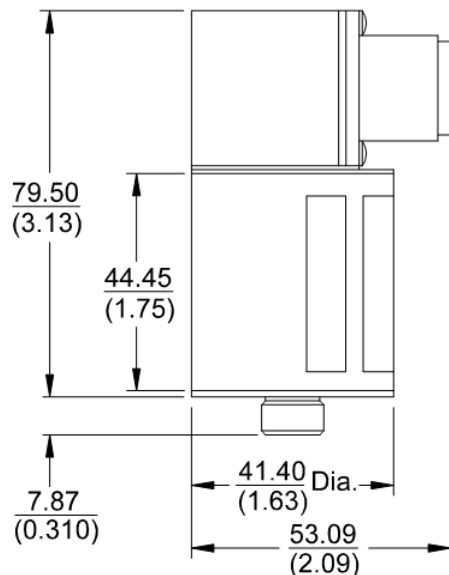


**Figure 3: Theoretical Phase Shift between Output and Case Velocity**

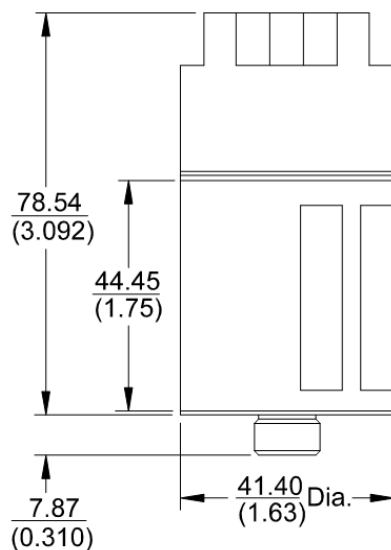


**Figure 4: Top Mounted Connector**

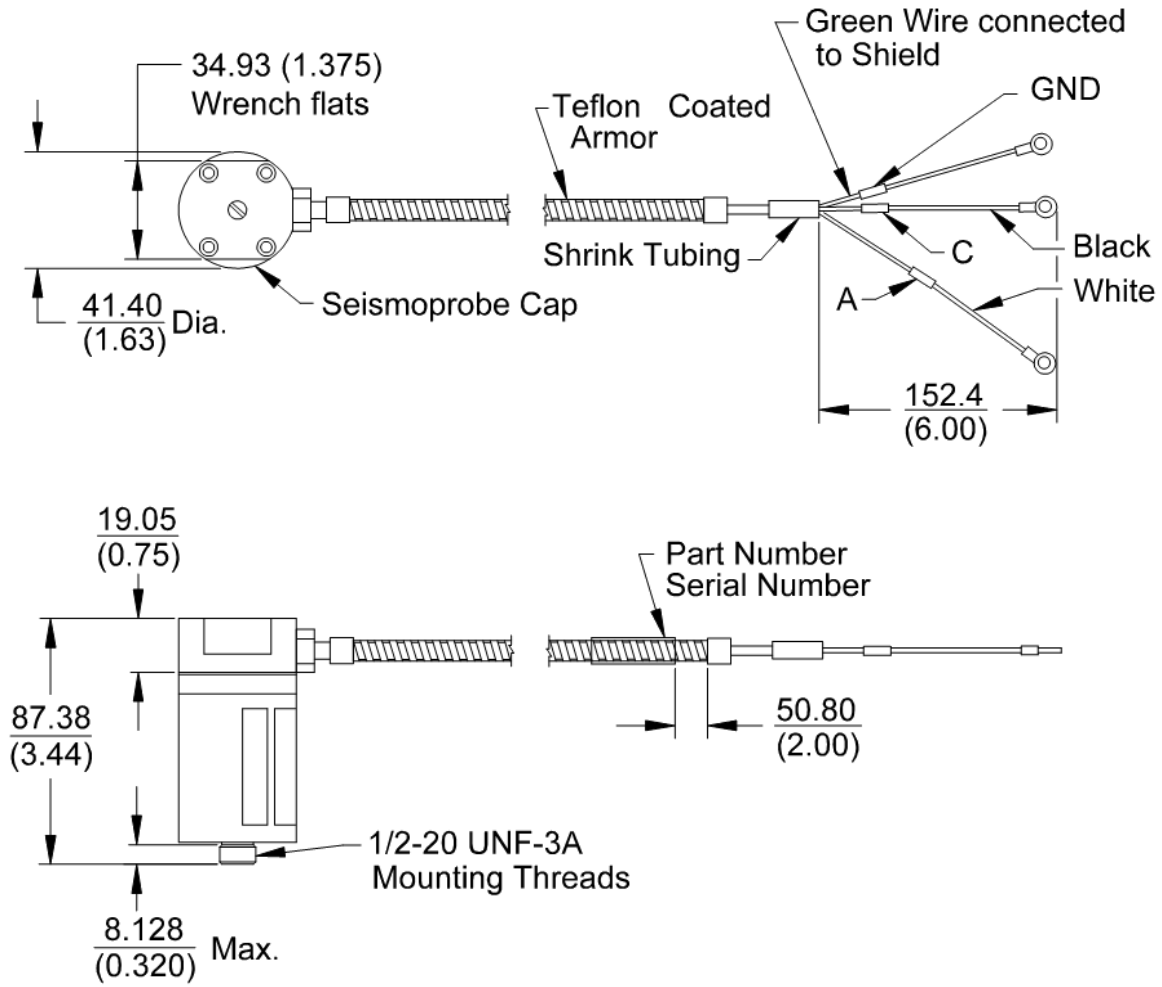
(9200 Option B-01 or 74712 Option C-02)  
 Note: All dimensions are shown in millimeters (inches)



**Figure 5: Side Mounted Connector**  
(9200 Option B-02 or 74712 Option C-04)

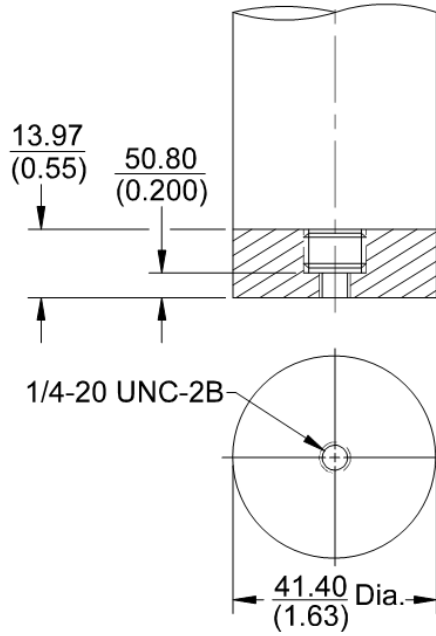


**Figure 6: Terminal Block Connector**  
(9200 Option B-05 or 74712 Option C-03)



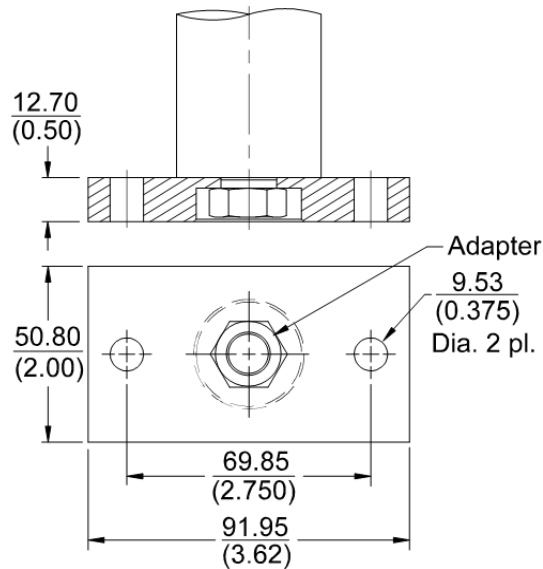
**Figure 7: 9200 Standard Integral Cable Options B-10 through B-50**

Integral cable is not available with the 74712 High Temperature Seismoprobe.



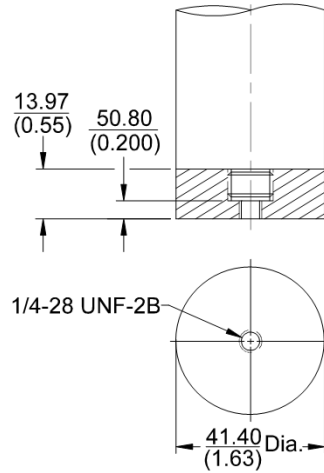
**Figure 8: 9200 (C) and 74712 (B) Mounting Base**

Option -01 Circular base for 1/4-20 UNC-2B stud, or  
Option -06 Isolated circular base for 1/4-20 UNC-2B stud.



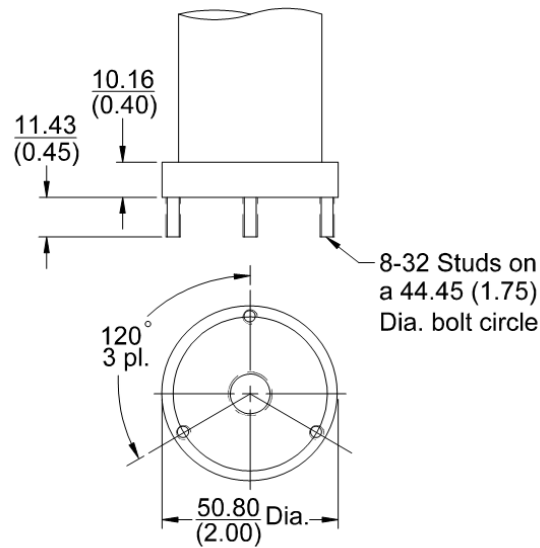
**Figure 9: 9200 (C) and 74712 (B) Mounting Base**

Option -03 Rectangular Flange, or  
Option -08 Isolated Rectangular Flange



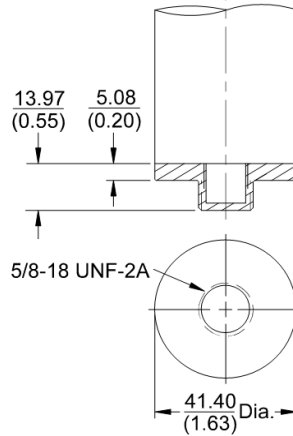
**Figure 10: 9200 (C) and 74712 (B) Mounting Base**

Option -02 Circular base for 1/4-28 UNF-2B stud, or  
Option -07 Isolated circular base for 1/4-28 UNF-2B stud



**Figure 11: 9200 (C) and 74712 (B) Mounting Base**

Option -04: Circular base with three 8-32 studs.



**Figure 12: 9200 (C) and 74712 (B) Mounting Base**

Option -09 Isolated circular base with 5/8-18 UNF-2A stud.

Copyright 2020 Baker Hughes Company. All rights reserved.



Bently Nevada, Orbit Logo and Velomitor are registered trademarks of Bently Nevada, a Baker Hughes Business, in the United States and other countries. The Baker Hughes logo is a trademark of Baker Hughes Company. All other product and company names are trademarks of their respective holders. Use of the trademarks does not imply any affiliation with or endorsement by the respective holders.

Baker Hughes provides this information on an "as is" basis for general information purposes. Baker Hughes does not make any representation as to the accuracy or completeness of the information and makes no warranties of any kind, specific, implied or oral, to the fullest extent permissible by law, including those of merchantability and fitness for a particular purpose or use. Baker Hughes hereby disclaims any and all liability for any direct, indirect, consequential or special damages, claims for lost profits, or third party claims arising from the use of the information, whether a claim is asserted in contract, tort, or otherwise. Baker Hughes reserves the right to make changes in specifications and features shown herein, or discontinue the product described at any time without notice or obligation. Contact your Baker Hughes representative for the most current information.

The information contained in this document is the property of Baker Hughes and its affiliates; and is subject to change without prior notice. It is being supplied as a service to our customers and may not be altered or its content repackaged without the express written consent of Baker Hughes. This product or associated products may be covered by one or more patents. See [Bentley.com/legal](https://www.bentley.com/legal).

1631 Bently Parkway South, Minden, Nevada USA 89423  
Phone: 1.775.782.3611 or 1.800.227.5514 (US only)  
[Bentley.com](https://www.bentley.com)