



PCTR

Resin Impregnated Paper Bushing Oil-oil Application

Grid Solutions' bushing excellence centre, former Passoni & Villa, has been synonymous with excellence, quality and competence in the field of high voltage for more than 80 years.

Around the world, the Passoni & Villa name represents a guarantee of excellent quality in the high voltage field. The company acquired this impressive reputation thanks to the constant and enthusiastic dedication of its human and technical resources.

Passoni & Villa began producing capacitance-graded bushings in 1924. Today it is acknowledged as one of the world's most reputable manufacturers. The accumulated experience and expertise of Passoni & Villa has now been applied to the design and manufacture of PCTR bushings.

A wealth of benefits and value-added features

The design, components and manufacturing technology of RIP bushings perform over an average lifetime in excess of 30 years under normal operating conditions. RIP bushings offer an array of benefits over conventional bushings (oil, gas, etc), including:

Increased Safety for Staff, the Substation and the Environment

RIP bushings are fire and explosion-proof. No oil and no SF₆ mean no environmental costs on end-of-life disposal and no leakage issues. No porcelain.

Installation Flexibility

Ease of transport, handling, storage and installation; installation and operation are possible in any position.

Seismic Solution

RIP bushings offer flexible retrofitting possibilities without concern for seismic withstand.

Maintenance Free

Passoni & Villa RIP bushings are 100% oil and pressure-free, so no specific maintenance or on-site verification are needed.

Superior Design for Increased Efficiency

- Compact, robust and reliable dry design. RIP solutions suitable for all transformer types and installation configurations are available
- Partial discharge-free up to double rated nominal voltage
- Excellent mechanical strength
- High thermal strength (class E, 120°C)
- Low dielectric losses (tg delta 0.35%)





Offering GE's Customers Decades of Experience and Expertise

Mario Villa and Carlo Passoni created the company in 1923 and started the production of bakelised paper tubes, never realising that it was destined to become a world leader in the high voltage field.

In their first 10 years of activity, the company built its reputation in Italy and in the 1940s their reputation spread to other European countries. It was only after World War II that the name began to be known outside Europe.

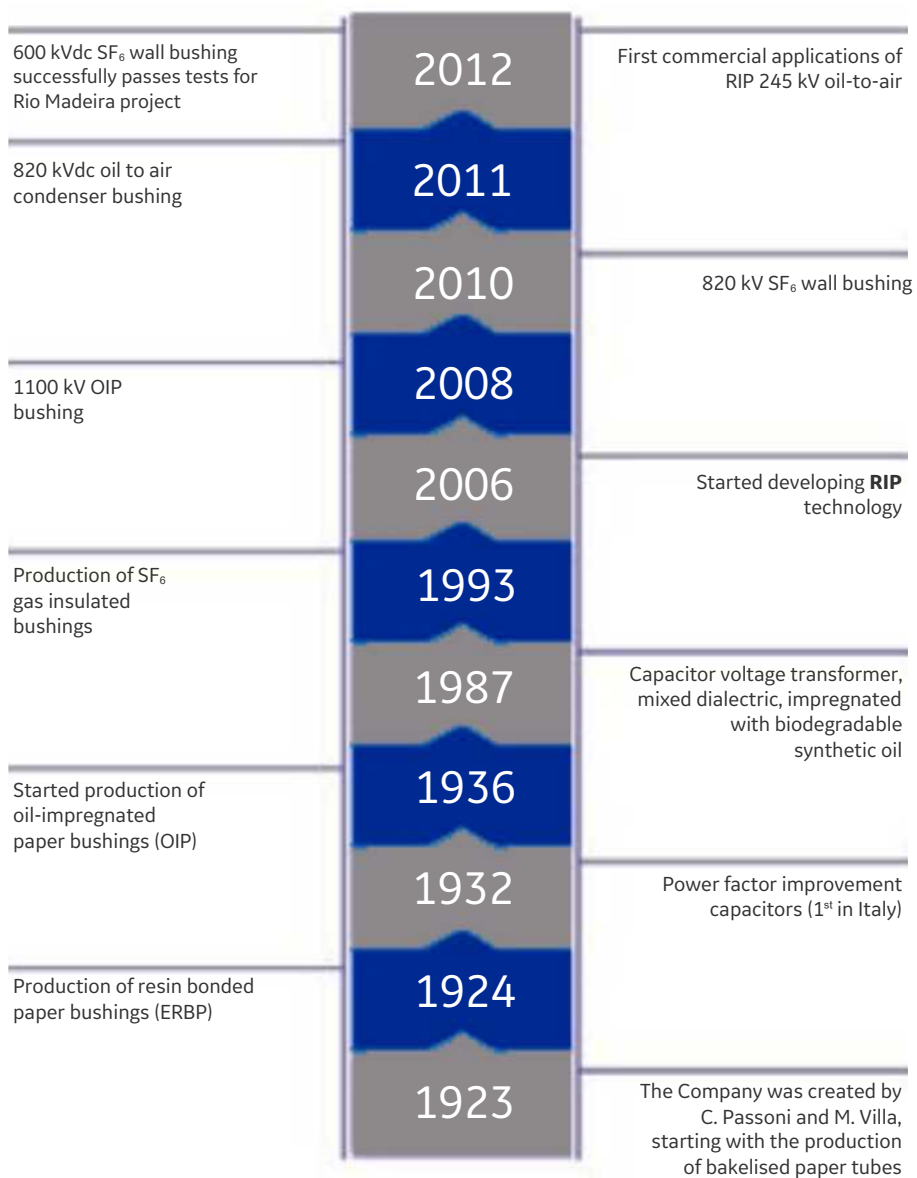

The company's mission has always been to invest all their energies into the search for product excellence in the worldwide high voltage market; a fascinating challenge that was awarded with an Honoris Causa degree in Electrical Engineering.

Since the early days, the company has grown in step with the market, reaching a leading position in its three sectors of production:

- High voltage transmission and distribution components
- Test equipment for high voltage laboratories
- Special high voltage applications

Key Benefits

- Longer lifetime and higher reliability
- Easy transport, handling, storage and installation
- Operational security
- Maintenance-free and environmentally-friendly
- Tailored to customer needs
- IEC 60137 and IEEE C57.19.01-2000 compliant



PCTR Bushings

Longer lifetimes and higher reliability

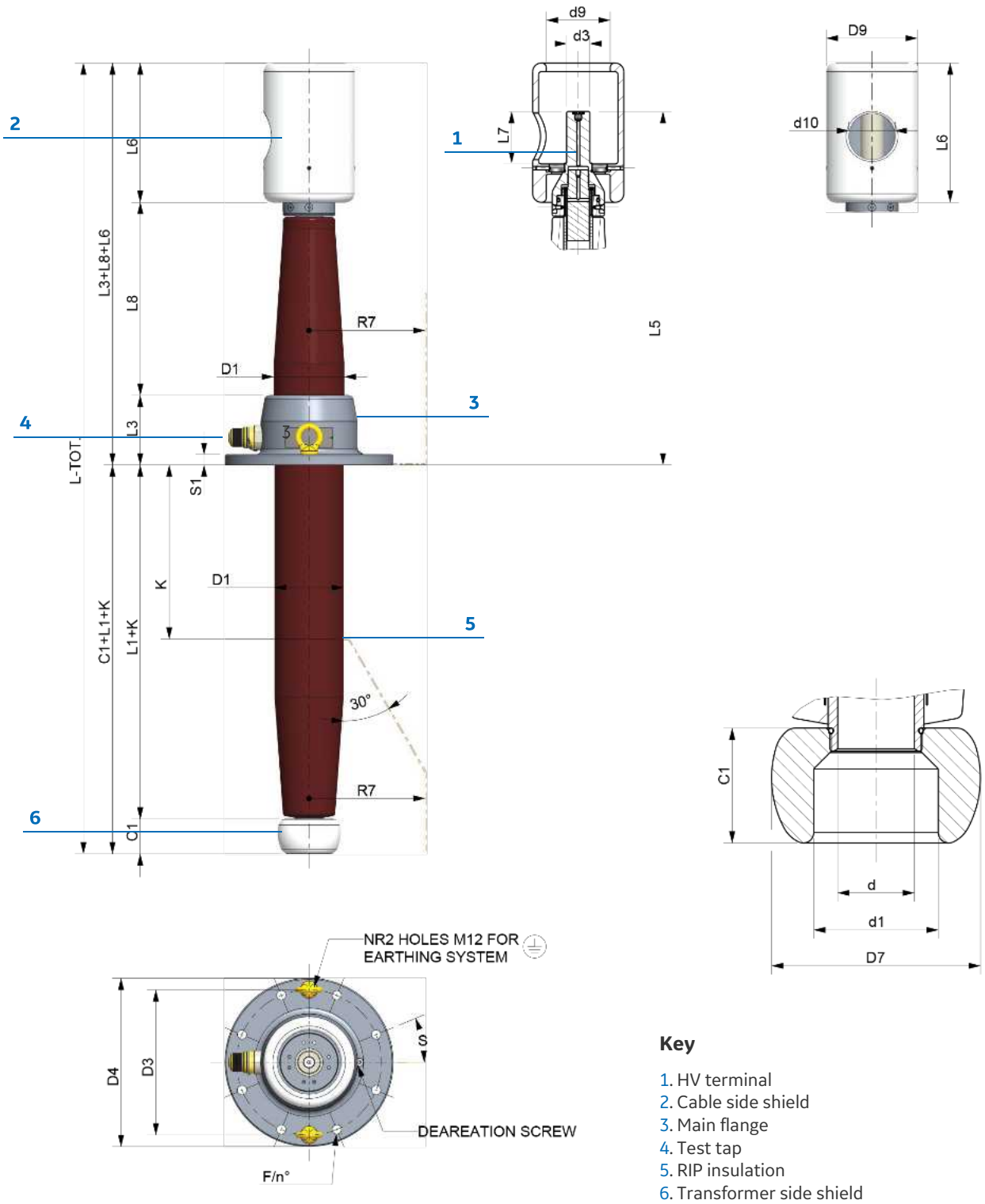

Electrical and Mechanical Data

Type and Current

RIP Type		72.5 kV		123 kV		145 kV		170 kV		245 kV	
Rated current	A	1250	*2000	1000	*2000	800	*1600	800	*1600	1600	*2000
Rated voltage	kV	72.5		123		145		170		245	
RATING acc.IEC 60137											
Rated phase to ground voltage	kV	42		71		84		98		141	
Power frequency withstand voltage for 60 sec	kV	155		255		305		355		505	
Lightning impulse withstand voltage	kV	325		550		650		750		1050	

Rating acc. IEEE C57.19.01 2000 annex A

Rated phase to ground voltage	kV	44	73	88	102	145
Power frequency withstand voltage for 60 sec	kV	160	260	310	365	425
Lightning impulse withstand voltage	kV	350	550	650	750	900

Bushing Dimensions

Cantilever load	N	1250	2000	3150	4000	3150	4000	4000			
CT extension	mm	0/300**		0/300**		0/300**		0/300**			
Weight	kg	13	23	22	36	30	44	35	49	38	110
L1	mm	175		310		360		422		596	
L3	mm	120		120		120		120		120	
L5	mm	477		609		662		722		966	
D1	mm	87		119		129		159		202	
D3	mm	185		250		290		290		400	
D4	mm	225		290		335		335		450	
D7	mm	109		109		150		150		203	
d1	mm	65		65		75		75		108	
c1	mm	60		60		90.5		90.5		163	
D9	mm	157		157		157		157		167	
L6	mm	240		240		240		240		280	
d	mm	40		40		40		40		65	
L7	mm	80		80		80		80		125	
d9	mm	110		110		110		110		135	
s1	mm	18		18		18		18		25	
F/n°	mm/n°	16/6		16/8		16/12		16/12		16/12	
s	mm	30		22.5		15		15		15	
R7	mm	125		200		225		260		350	
d10	mm	80		80		80		80		100	
d3	mm	40		40		40		40		60	
L8	mm	201		333		390		446		628	

Rated Current

Draw lead	A	1250	1000	800	800	1600
Draw rod	A	2000	2000	1600	1600	2000

* draw-rod application

** standard values; other dimensions available upon request

Components

Flange

The flange is made of aluminium and equipped with lifting holes, deaeration screw and a power factor tap (tested at 3 kV for 60 s.).

Top Terminal

The standard bushing top terminal is made of aluminium with no surface treatment. On request, it can be supplied in tinned or silvered copper. Draw-lead or draw-rod type bushings (rated current up to 2,000 A) have a removable top terminal. This terminal is connected to the copper inner terminal lug or the draw rod by means of multi-blade contacts and is screwed to the bushing head. In bottom-connected bushings, the inner non-removable rod also acts as the top terminal.

Top Terminal Shield (Cable Side)

Depending on the design, the transformer side as well as the cable side can be shielded by electrical screens. The transformer side screen is equipped with a fixation system which allows moving the shield top and down side as well as a specific fixation radial side wise. The cable side screen is designed as coated aluminium screen inclusive, with a 90° entrance for the cable connection.

Power Factor Measuring Tap

The PF tap is the connection to the outer conducting layer of a capacitance graded bushing. It is accessible from outside the bushing, insulated from the flange or other fixing device and measures the dissipation factor, capacitance and partial discharge while the bushing flange is earthed. A suitable fully mounted PF measuring tap is supplied with all RIP bushings.

Power Factor Tap Extension

The test tap can be led out as insulated flexible wire and is equipped with a traction relief in the flange. If the bushing is dispatched, this flexible wire is screwed to the flange with a cable lug which is grounded.

Note 1: the cable is led outside of the transformer and fixed on a standard test tap.

Note 2: this device is an accessory and not part of the standard delivery.



Remote PF tap with cable

Cable side shield

Flange assembly

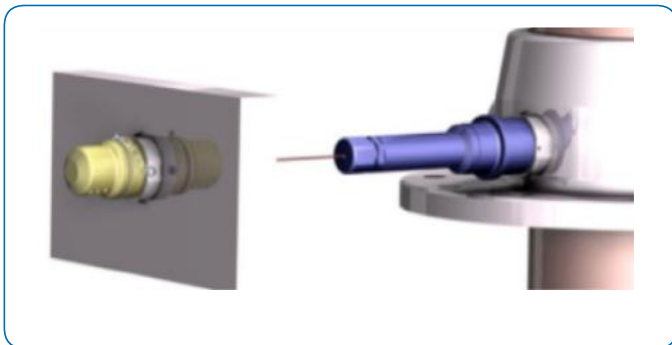

Mounting of remote PF tap with cable

Grid Solutions dry bushings
Long life, excellent reliability

Packing and Transportation

After testing and before packing, the bushing is cleared of any dust. Dry insulated bushings are easy to transport and handle. There is no risk of oil or gas leakage during handling.

Name Plate

Each bushing is provided with a name plate containing complete electrical data and its serial number in accordance with IEC/IEEE requirements. The aluminium name plate is secured to the flange with rivets and carries the following information:

PASSONI VILLA	MILAN ITALY	SERIAL NR.	<input type="text"/>
PASSANTE-BUSHING-TRAVERSEE-DURCHFUEHRUNG			
TYPE <input type="text"/>			
⊙	STD REF. <input type="text"/>	50-60Hz	⊙
Um	<input type="text"/> kV	BIL/SIL/AC	<input type="text"/> kV Ir <input type="text"/> A
C1	<input type="text"/> pF	C2	<input type="text"/> pF P.F. <input type="text"/> % AT 10kV/20°C
<input type="text"/>	<input type="text"/> kg	<input type="text"/>	

Identification name plate



Self-checking process during production



Onsite Bushing Renovation and Replacement

The regular measurement of main electrical parameters and oil conditions can drastically reduce the risk of catastrophic failures. The assessment of bushing conditions allows us to define the appropriate service to undertake to ensure transformers are operating safely and efficiently.

Our experts conduct diagnostics onsite for bushings of any brand and any type of technology: measurement of C and Pf % in a frequency range of 0 to 1 kHz, thermal scan and visual inspections. When necessary, we can also carry-out inspections at our factory and laboratory, including: repetition of complete routine test, dissolved gas analysis of insulating oil, failure analysis.

Based on the situation and customer requirements, our experts recommend either renovation or the replacement of the bushing:

Onsite Renovation

Replacement of small components (oil level indicators, test taps, top terminals, pressure gauges, etc.), restoration of correct oil level or pressure for pressurised bushings.

Workshop Renovation

Disassembling of the complete bushings for replacement of main components (porcelain, flanges, condenser, cores, etc.) and replacement of insulating oil.

Replacement

Supply of new bushings fully interchangeable with the old ones.



Following the acquisition of PASSONI & VILLA, Grid Solutions now offers a large portfolio of condenser bushings for AC or DC operation. If you require any further information, please address your queries to rpv@ge.com

For more information please contact
GE
Grid Solutions

Worldwide Contact Center

Web: www.GEGridSolutions.com/contact
Phone: +44 (0) 1785 250 070

GEGridSolutions.com

IEC is a registered trademark of Commission Electrotechnique Internationale. IEEE is a registered trademark of the Institute of Electrical Electronics Engineers, Inc.

GE and the GE monogram are trademarks of General Electric Company.

GE reserves the right to make changes to specifications of products described at any time without notice and without obligation to notify any person of such changes.

PCTR-Brochure-EN-2019-03-Grid-PTR-0233. © Copyright 2019, General Electric Company. All rights reserved.



Imagination at work