

PNR

Resin Impregnated Paper Bushing 72,5 to 420 kV

The design, components and manufacturing technology of RIP bushings add up to an average lifetime in excess of 30 years under normal operating conditions.

Dry bushings They last and last

GE, a company you can trust to harness your power: following the acquisition of Passoni and Villa in 2008, former Alstom Grid now Grid Solutions offers a wide range of condenser bushings for AC or DC applications. Today it is acknowledged as one of the world's most reputable bushing manufacturers. Its accumulated experience and expertise have been applied to the design and manufacture of PNR bushings.

A Wealth of Benefits

The design, components and manufacturing technology of RIP bushings perform over an average lifetime in excess of 30 years under normal operating conditions. RIP bushings offer an array of benefits over conventional bushings (oil, gas, etc).

RIP solutions suitable for all transformer types and installation configurations are available.

Installation Flexibility

Ease of transport, handling, storage and installation; installation and operation are possible in any position.

Seismic Solution

RIP bushings offer flexible retrofitting possibilities without concern for seismic withstand.

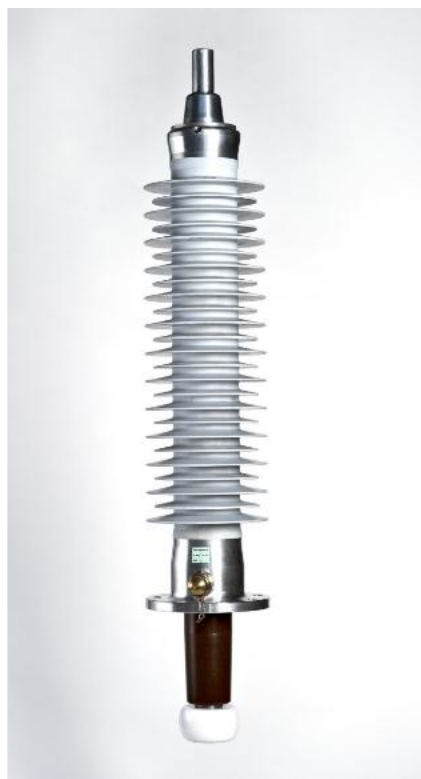

Superior Design for Increased Efficiency

- Compact, robust and reliable dry design.
- Partial discharge-free up to double rated nominal voltage
- Excellent mechanical strength
- High thermal strength (class E, 120°C)
- Low dielectric losses (tgΔ 0.35%)

Increased Safety

- For Staff, the Substation and its Environment
- RIP bushings are fire and explosion-proof
- No oil and no SF₆ mean no environmental costs on end-of-life disposal and no leakage issues. No porcelain.

Maintenance Free

GE RIP bushings are 100% oil and pressure-free, so no specific maintenance or on-site verification are needed.



PNR Components

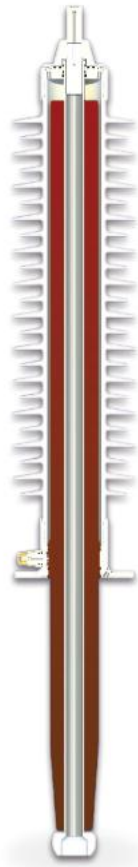

Construction

1. HV terminal
2. Conductor
3. RIP condenser core
4. Polyurethane filling
5. Composite insulator
6. Test tap
7. Main flange

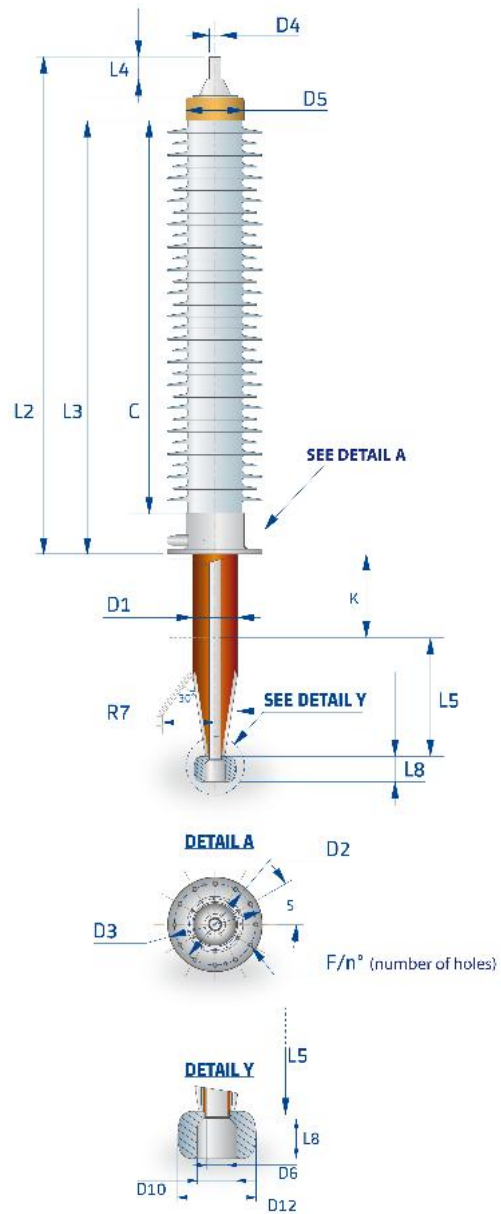

Name Plate

Each bushing is provided with a name plate containing complete electrical data and its serial number in accordance with IEC/IEEE requirements. The aluminium name plate is secured to the flange with rivets and carries the following information:

PASSANTE-BUSHING-TRAVERSEE-DURCHFÜHRUNG		MILAN ITALY		SERIAL NR. <input type="text"/>
TYPE <input type="text"/>				
STD REF. <input type="text"/>	50-60Hz			
Um <input type="text"/> kV	BIL/SIL/AC <input type="text"/>	kV	Ir <input type="text"/>	A
C1 <input type="text"/> pF	C2 <input type="text"/> pF	P.F. <input type="text"/>	% AT 10kV/20°C	
<input type="text"/> kg	<input type="text"/>			

Electrical and Mechanical Data

RIP Type		PNR	72.5 kV	123 kV	145 kV	170 kV	245 kV	420 kV
Rated current ¹	- Draw-lead	A	1000	800	800	800	1250	1250
	- Draw-rod ²	A	1600	1600	1250	1250	1600	
Rated voltage		kV	72.5	123	145	170	245	420

Rating acc. IEC 60137

Rated phase to ground voltage		kV	42	71	84	98	142	242
Power frequency withstand voltage for 60 s.		kV	155/140	255/230	305/275	355/325	505/460	750
Lightning impulse withstand voltage		kV	325	550	650	750	1050	1550

Rating acc. IEEE C57.19.01 2000 annex A

Rated phase to ground voltage		kV	44	73	88	102	146	
Power frequency withstand voltage for 60 s		kV	160/140	260/230	310/275	365/315	425/350	
Lightning impulse withstand voltage		kV	350	550	650	750	900	

Technical Characteristics

Colour of insulator		RAL	7047	7047	7047	7047	7047	7047
Creepage distance		mm	2450	3880	5250	5500	8200	14447
Arcing distance		mm	710 ±5	1035 ±5	1360 ±5	1460 ±5	2190 ±5	3750 ±5
Cantilever test load 1 min.		N	2000	3150	3150	4000	4000	4000
Partial discharge at double rated voltage		pC				< 5		
Installation						Vertical up to horizontal		
Test voltage of P.F. tap		kV				1 min. 3 kV		
Installation altitude		m				1000		
Operation temperature		°C				-25 up to + 80		

¹ Higher ratings available on request ; ² Details will be provided upon request

Dimensions

C		mm	663	1002	1310	1390	2146	3750
L2		mm	1003	1378	1670	1773	2653	4400
L3		mm	794	1150	1445	1545	2353	4060
L4		mm	80	80	80	80	125	80
L5		mm	173	310	360	422	597	757
L8		mm	48	48	79	79	161	255
K*		mm	0/300	0/300	0/300	0/300	0/300	0/300
D1		mm	87	119	129	159	202	319
D2		mm	185	250	290	290	400	450
D3		mm	225	290	335	335	450	500
D4		mm	40	40	40	40	40	40
D5		mm	135	177	177	207	275	500
F/n°		mm/n°	16/6	16/8	16/12	16/12	23/12	23/12
D6		mm	40	40	40	40	65	65
D10		mm	65	65	75	75	110	166
D12		mm	109	109	150	150	201	291
S		°	60	45	30	30	30	30
R7		mm	125	200	225	260	350	500
Weight								
K0 (Draw-lead /Draw-rod)		kg	33/42	71/86	93/117	110/135	286/290	975/-
K300 (Draw-lead /Draw-rod)		kg	35/48	77/95	96/121	119/145	298/350	1000/-

*: Standard

GE Dry Bushings- Long life, Excellent Reliability

Flange

The flange is made of aluminum and equipped with lifting holes and a power factor tap (tested at 3 kV for 60 s) and/or voltage tap, on request.

Polyurethane Filling

The hollow space between the RIP core and the housing is dry-filled with polyurethane. Dry filling totally removes the risk of pollution (as in SF6 filling) and is totally leakage proof should any damage exceptionally occur. Polyurethane was chosen for its high mechanical and electrical properties. High compressibility polyurethane makes the bushings more resistant to mechanical stress caused by thermal variation.

Top Terminal

The standard bushing top terminal is made of aluminium with no surface treatment. On request, it can be supplied in tinned or silvered copper. Draw-lead or draw-rod type bushings (rated current up to 2,000 A) have a removable top terminal. This terminal is connected to the copper inner terminal lug or the draw rod by means of multi-blade contacts and is screwed to the bushing head. In bottom-connected bushings, the inner non-removable rod also acts as the top terminal.



High voltage terminal

Packing and Transportation

After testing and before packing, the bushing is cleared of any dust. Dry insulated bushings are easy to transport and handle. There is no risk of oil or gas leakage during handling.

Power Factor Measuring Tap

The PF tap is the connection to outer conducting layer of a capacitance - graded bushing. It is accessible from outside the bushing, insulated from the flange or other fixing devices, and measures the dissipation factor, capacitance and partial discharge while the bushing flange is earthed. A suitable fully mounted PF measuring tap is supplied with all RIP bushings.

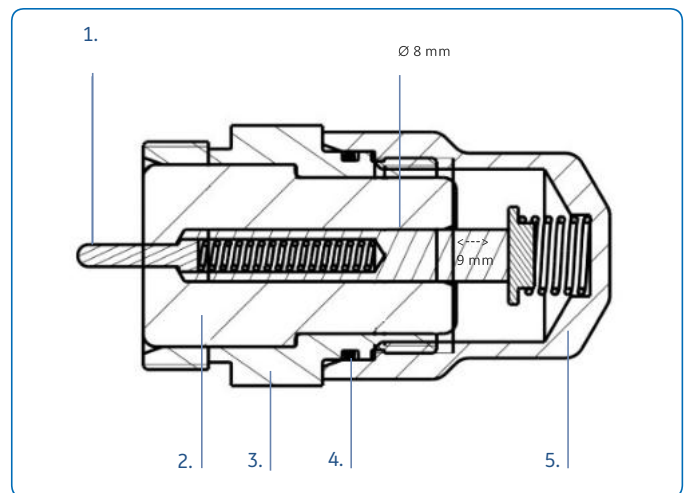

1. Measurement electrode
2. Insulating bushing
3. Tap body
4. Gasket
5. Closing and grounding cap

For more information please contact
GE
Grid Solutions

Worldwide Contact Center

Web: www.GEGridSolutions.com/contact
Phone: +44 (0) 1785 250 070

GEGridSolutions.com

IEC is a registered trademark of Commission Electrotechnique Internationale. IEEE is a registered trademark of the Institute of Electrical Electronics Engineers, Inc.

GE and the GE monogram are trademarks of General Electric Company.

GE reserves the right to make changes to specifications of products described at any time without notice and without obligation to notify any person of such changes.

PNR-Brochure-EN-2019-07-Grid-PTR-0307. © Copyright 2019, General Electric Company. All rights reserved.



Imagination at work