



PTFR

High Current Condenser Bushing 24-36 kV Oil-to-Air - Resin Impregnated Paper

PTFR are capacitance graded bushings with resin impregnated paper insulation. They are designed for use on power transformers, installed in any position, in compliance with the latest edition of IEC 60137. Design, components and manufacturing technology guarantee an average life time longer than 30 years under normal operating conditions.

Manufacturing of Capacitance Graded Bushings

The main electrical component is the condenser body that is manufactured using resin-impregnated paper (RIP) technology. This technology utilizes a continuous sheet of pure crepe paper, wound around a support tube. During the winding process, the first step is to reduce its water content to 1% maximum by drying the paper with heated cylinders and infrared rays. During winding, a series of aluminum foils are coaxially inserted between the layers of the paper in order to grade the best possible distribution of radial and longitudinal electrical gradients between the central conductor and the grounded flanges. The winding and foil placement is made by computer-controlled machines. After winding, each condenser core is placed into an autoclave for resin impregnation under vacuum. Each core is then machined to achieve the final shape.

Standards

- IEC 60137

Key Benefits

- Bushings with longer lifetime and higher reliability
- Possibility to use bushings under extreme weather condition
- No performance reduction with age
- Partial discharge free
- Installation in any position



PTFR Bushings Main Features

Resin Impregnated Paper High current IEC Standards

- Rated voltages 24 and 36 kV
- Air side : porcelain insulator
- Oil side : resin impregnated paper winding
- Inner conductor made of cast aluminum
- Dry filling of the interspace between porcelain and condenser body
- Installation in any position
- Flange of aluminum alloy casting
- Maximum current rating up to 24.000 A
- Flange provided with power factor tap and Buchholz relay connection

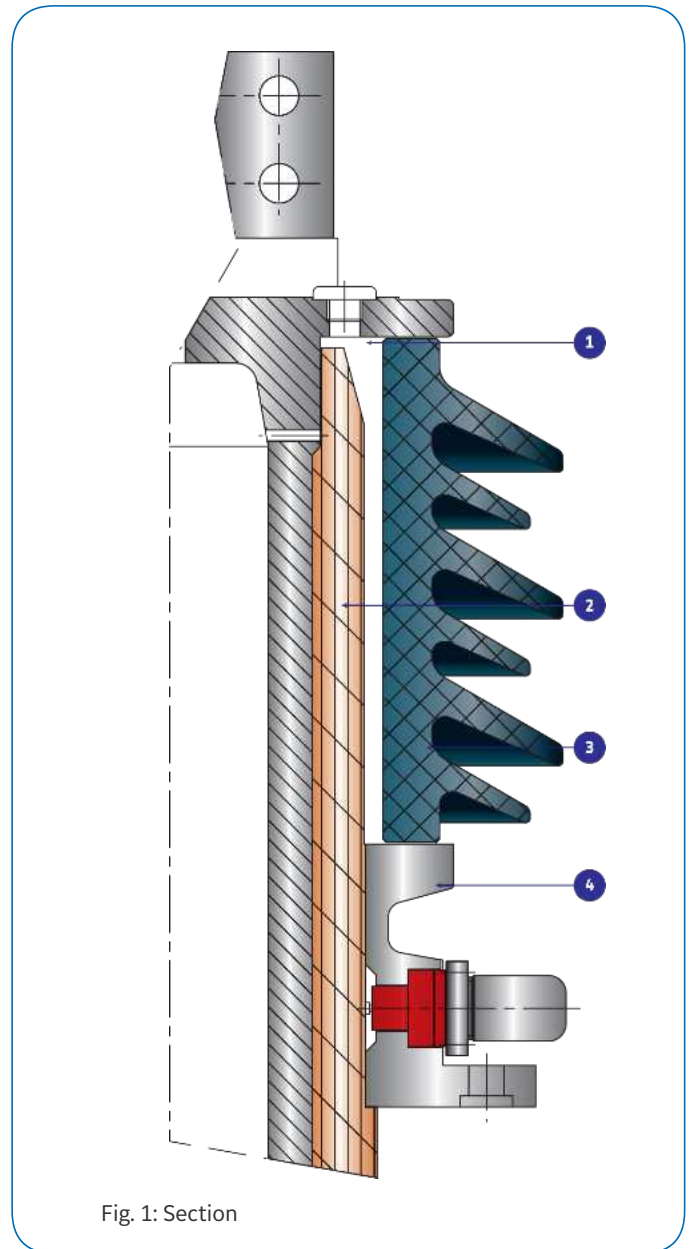

Fig. 1: Section

Fig. 1: Section

1. Dry filling
2. Condenser body
3. Porcelain insulator
4. Flange

Bushing Designation

PTFR.24.125.12000

PTFR	Condenser bushings, transformer (for use on), high current, Resin impregnated Paper (RIP) technology
24	Insulation class in kV
125	BIL in kV
12000	Rated current in A

Air Side

The air side envelope is made of brown colored porcelain. The creepage distance is for a very high polluted atmosphere (VhP) equivalent to 31 mm/kV. The shed configuration is alternate-type (small-large sheds). This is the most effective solution, proven by salt tests and the profile of sheds complies with the recommendations of IEC 60815.

The air extremity of the bushing inner conductor is provided by two or more palms for the connections of the bus bars, which are normally enclosed in a metal clad duct.

Oil Side

The condenser body is immersed in the transformer oil and is hermetically sealed to the flange. The springs, located on the oil side, are used for mechanical coupling of all bushings parts and to avoid shifting due to the thermal variations. The oil extremity of the inner conductor is provided with one or more palms for the connection to the transformer windings.

Current Ratings

The acceptable operating currents versus oil temperatures and busduct air compared to conductor can be calculated using the following formula:

$$I_{na} = I_n \times \alpha \times \beta$$

where:

- I_{na} continuous admissible current [A]
- I_n nominal bushing current [A]
- α temperature coefficient
- β CT space coefficient

α and β can be determined using the tables here below, where:

- T_c admissible conductor temperature (120°C)
- T_a ambient (bus duct) air temperature (°C)
- T_o transformer oil temperature (°C)
- K CT space (mm)

$T_c - T_a$ (°C)		Coefficient α (36 kV Type)				
90	0.76	0.83	0.92	0.99	1.06	
80	0.72	0.79	0.88	0.96	1.03	
70	0.67	0.76	0.85	0.93	1.01	
60	0.63	0.73	0.82	0.91	1.00	
50	0.59	0.70	0.79	0.89	0.99	
40	0.55	0.66	0.76	0.86	0.96	
30	0.50	0.63	0.73	0.84	0.95	
20	0.46	0.59	0.70	0.81	0.93	
10	0.43	0.56	0.67	0.79	0.91	
$T_c - T_o$ (°C)	10	20	30	40	50	

CT Space K (mm)	Coefficient β			
	24 kV Type		36 kV Type	
	$T_a = 40^\circ\text{C}$	$T_a = 80^\circ\text{C}$	$T_a = 40^\circ\text{C}$	$T_a = 80^\circ\text{C}$
0	1.00	1.00	1.00	1.00
100	0.94	0.99	0.97	0.99
200	0.87	0.97	0.90	0.95
300	0.81	0.95	0.84	0.91
400	0.75	0.91	0.79	0.87
500	0.68	0.87	0.75	0.83
600	0.61	0.81
700	0.55	0.75

Conductor and terminals

Both sides of the conductor and terminals are made from a unique cast aluminum alloy, which has an IACs 55% conductivity. Terminal surfaces are not treated. upon request it is possible to provide them with 10 micron silver plating.

Flange

The flange is made from cast aluminum, and is equipped with lifting holes, a power factor tap (tested at 2 kV for 60 s) (fig. 2) and Buchholz relay connection (1/2" gas outlet plug) (fig. 6).

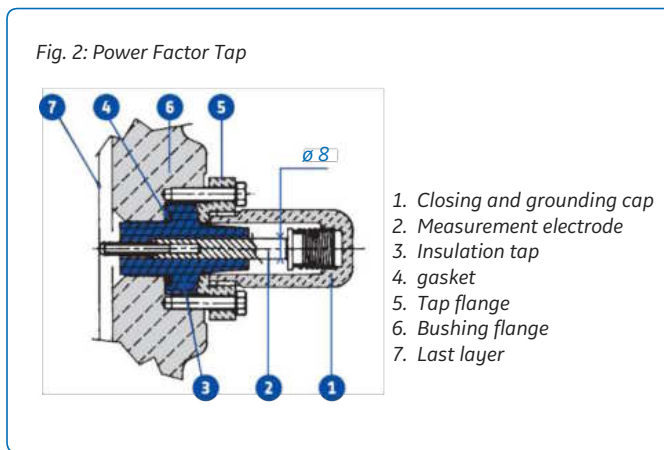

$T_c - T_a$ (°C)		Coefficient (24 kV Type)				
90	0.83	0.91	1.01	1.09	1.16	
80	0.80	0.87	0.97	1.05	1.13	
70	0.74	0.83	0.93	1.02	1.11	
60	0.69	0.80	0.90	1.00	1.10	
50	0.65	0.77	0.87	0.98	1.09	
40	0.61	0.73	0.84	0.96	1.08	
30	0.57	0.70	0.82	0.94	1.07	
20	0.53	0.66	0.79	0.92	1.06	
10	0.50	0.63	0.76	0.90	1.05	
$T_c - T_o$ (°C)	10	20	30	40	50	

Assembling

The coupling between porcelains and metal parts (flange and inner conductor) is achieved with helicoidal springs, placed in the oil side of the bushings.

Gaskets

Made of Viton® a fluorocarbon rubber elastomer (FPM), o-ring type. They are compatible with all the fluids they are in contact with (transformer mineral oil). Air side gaskets are carefully protected, by means of a sealing, against influence of polluting weather elements. For special requirements, such as low ambient temperatures (down to -55°C), special o-rings are used.



Fig. 3 Cross-section

Dry filling

PTFR bushings can be installed in any position because the interspace between porcelain and condenser body is filled with a dry mass (polyol-isocyanate).

This material offers:

- Low dielectric losses
- Good level of partial discharges
- Good thermal resistance
- Constant characteristics versus time

Dry filling improves reliability in comparison with oil filled type and makes installation simpler: no oil leakage and, if horizontal installation, no oil reservoir.

Tests

All bushings have electrical characteristics that are tested in compliance with the last edition of IEC 60137-Publication insulated bushings for alternating voltages above 1000 V, and Main National standards.

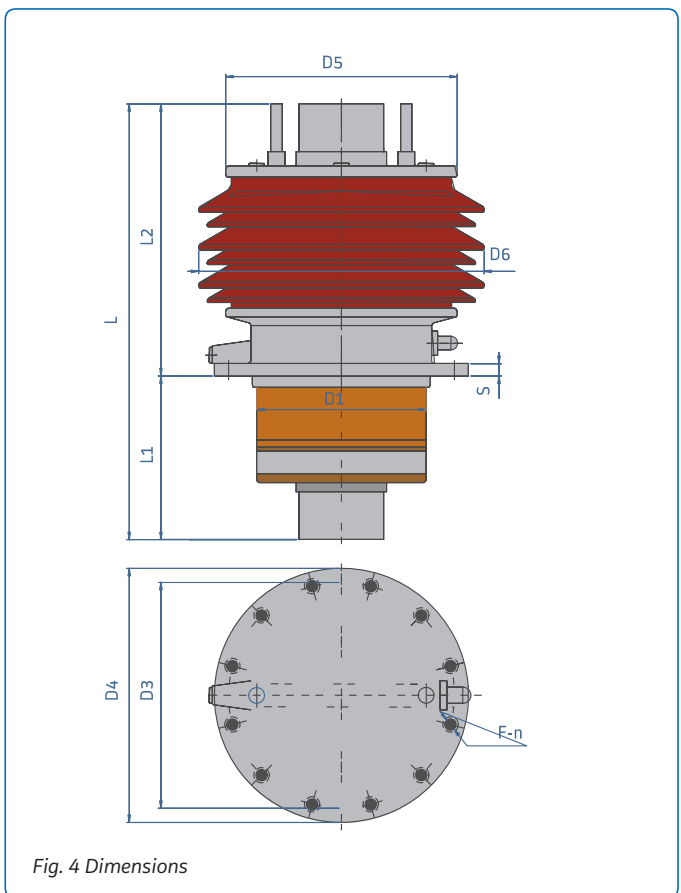

Fig. 4 Dimensions

PTFR Range - 24 / 36 kV: Ratings / Dimensions

Type	Rated Voltage	Rated phase to earth voltage BIL	Dry power frequency withstand voltage (60")	Wet power frequency withstand voltage (60")	Dry lightning impulse withstand voltage	Rated current	Free insulation length in air	Min. nominal creepage distance	Pair of sheds (small + large)	Cantilever load	Weight*	Max. operating altitude
Type	kV	kV	kV	kV	kV	A	mm	mm	n°	N	kg	m
24.150.7500	24	14	60	50	150	7500	230	828	3	3150	60	1000
24.150.9000	24	14	60	50	150	9000	230	828	3	3150	78	1000
24.150.12000	24	14	60	50	150	12000	230	828	3	3150	85	1000
24.150.15000	24	14	60	50	150	15000	230	828	3	3150	119	1000
24.150.19000	24	14	60	50	150	19000	230	828	3	3150	134	1000
24.150.24000	24	14	60	50	150	24000	230	828	3	3150	155	1000
36.200.7500	36	21	80	75	200	7500	460	1650	6	3150	90	1000
36.200.9000	36	21	80	75	200	9000	460	1650	6	3150	110	1000
36.200.12000	36	21	80	75	200	12000	460	1650	6	3150	126	1000
36.200.15000	36	21	80	75	200	15000	460	1590	6	3150	154	1000
36.200.19000	36	21	80	75	200	19000	460	1650	6	3150	215	1000
36.200.24000	36	21	80	75	200	24000	460	1650	6	3150	235	1000

Type	L*	L1*	L2	D1	D3	D4	D5	D6	NR	F	S	Top Palm Fig.	Bottom Palm Fig.
Type	mm	mm	mm	mm	mm	mm	mm	mm	N°	mm	mm	Fig.	Fig.
24.150.7500	770	290	480	190	290	335	260	360	12	16	19	7	8
24.150.9000	770	290	480	218	290	335	345	445	12	16	19	9	10
24.150.12000	770	290	480	255	350	400	345	445	12	20	21	11	12
24.150.15000	770	290	480	300	400	450	410	525	12	20	22	13	14
24.150.19000	770	290	480	360	450	500	460	555	12	20	22	15	16
24.150.24000	860	290	480	435	535	590	530	625	16	22	23	17	18
36.200.7500	1030	320	710	190	290	335	260	360	12	16	19	7	8
36.200.9000	1030	320	710	218	290	335	345	445	12	16	19	9	10
36.200.12000	1030	320	710	255	350	400	345	445	12	20	21	11	12
36.200.15000	1030	320	710	300	400	450	410	525	12	20	22	13	14
36.200.19000	1030	320	710	360	450	500	460	555	12	20	22	15	16
36.200.24000	1030	320	710	435	535	590	530	625	16	22	23	17	18

(*) Only for min. CT space = 0 mm
Other available standard CT space: 300 mm

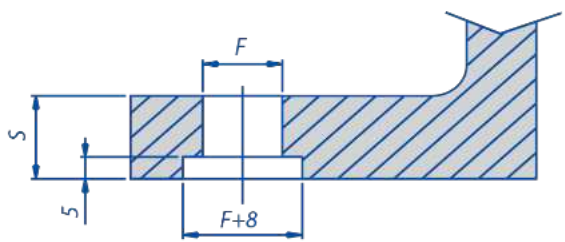

Fig. 5: Flange fixing holes

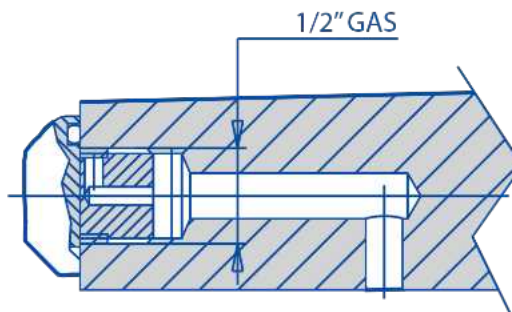

Fig. 6: Buchholz relay connection

Top Palms

7500 A

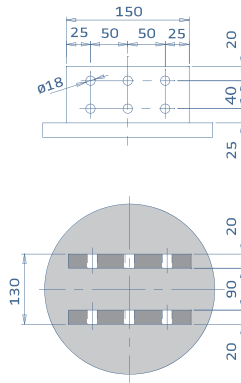

Fig. 7

9000 A

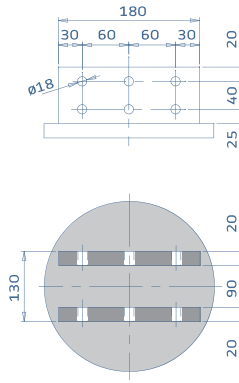

Fig. 9

12000 A

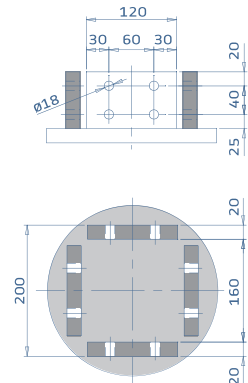

Fig. 11

Bottom palms

7500 A

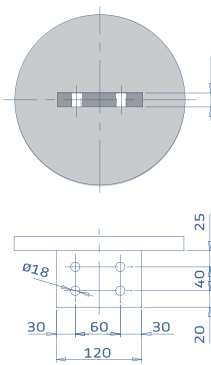

Fig. 8

9000 A

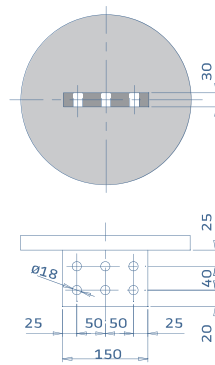

Fig. 10

12000 A

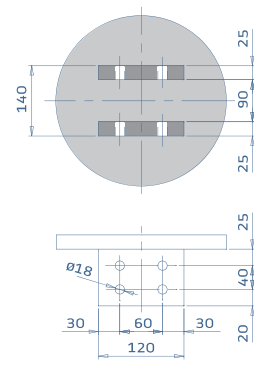

Fig. 12

Top Palms

15000 A

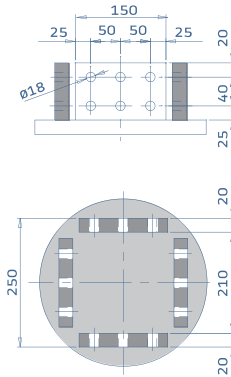

Fig. 13

19000 A

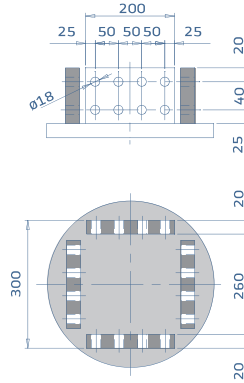

Fig. 15

24000 A

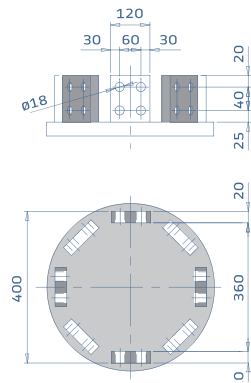

Fig. 17

Bottom palms

15000 A

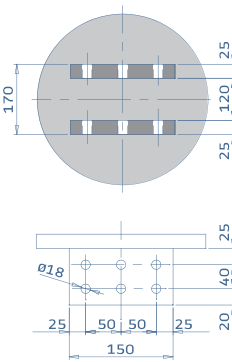

Fig. 14

19000 A

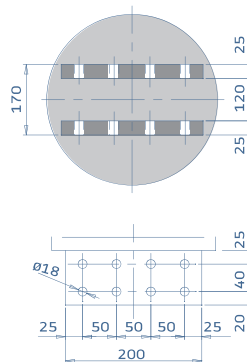

Fig. 16

24000 A

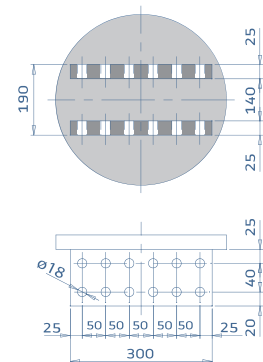

Fig. 18

Nameplate

Each bushing is provided with a name plate, (fig. 19) with all the electrical data and serial number, in accordance with the prescription of IEC standards. The aluminium plate is placed on the flange by rivets.

Name plate detail

PASSONIVILLA	MILAN ITALY	SERIAL NR.	<input type="text"/>
PASSANTE-BUSHING-TRAVERSEE-DURCHFÜHRUNG			
TYPE <input type="text"/>			
<input type="radio"/>	STD REF. <input type="text"/>	50-60Hz	<input type="radio"/>
Um	<input type="text"/> kV	BIL/SIL/AC	<input type="text"/> kV
		Ir	<input type="text"/> A
C1	<input type="text"/> pF	C2	<input type="text"/> pF
		P.F.	<input type="text"/> %
		AT 10kV/20°C	
<input type="checkbox"/>	<input type="checkbox"/>	kg	<input type="text"/>

Fig. 19: Name Plate

For more information please contact
GE
Grid Solutions

Worldwide Contact Center

Web: www.GEGridSolutions.com/contact
Phone: +44 (0) 1785 250 070

GEGridSolutions.com

IEC is a registered trademark of Commission Electrotechnique Internationale. IEEE is a registered trademark of the Institute of Electrical Electronics Engineers, Inc. Modbus is a registered trademark of Schneider Automation. NERC is a registered trademark of North American Electric Reliability Council. NIST is a registered trademark of the National Institute of Standards and Technology.

GE and the GE monogram are trademarks of General Electric Company.

GE reserves the right to make changes to specifications of products described at any time without notice and without obligation to notify any person of such changes.

PTFR-Brochure-EN-2019-02-Grid-PTR-0234. © Copyright 2019, General Electric Company. All rights reserved.



Imagination at work