

Reason DR60

Digital Recorder and PMU

The Reason DR60 is a centralized one-box multifunctional digital fault recorder (DFR). The small form factor, together with the ruggedness of design drawn from field experience in yard-mounted applications, ensures that the Reason DR60 can be installed in harsh utility and industrial environments. The high scalability in binary I/O counts along with modern communications such as IEC61850 Edition 2 and synchronization protocols such as MMS, GOOSE and PTP precision-timing, place the DR60 at the forefront of digital fault recording technology.

Full system awareness

The DR60 outstanding performance, high accuracy and complete set of functionalities provide data for several applications and analysis, such as:

- Network faults
- Performance of the protective IEDs
- Dynamic response of the network
- Long-term trends
- Revenue readings
- Asset Management

IEC 61850, born and bred

Born with IEC 61850 spirit, this is the DR60 motto. That means all its internal functions are implemented and mapped according to IEC 61850 ed.2 logical nodes and data models. Even its configuration is performed using native SCL files. It features MMS report control blocks for communication with supervisory systems and GOOSE publisher and subscriber for interaction with other IEDs through the IEC 61850 process bus.

Substation Protocols and Standards

The DR60 Digital Recorder offers what is best for high-quality measurements, synchronization, communication and security. To do so, the DR60 utilizes well-recognized protocols for time synchronization and communication, such as: IEEE1588v2, MMS and GOOSE. The DR60 is full compliant with NERC CIP-5 and integration with Internet of Things (IoT) through Predix applications are scheduled for future firmware releases.

Ready for today's and tomorrow's substations

The DR60 is a modern and flexible solution that meets current and future application requirements granting the best that the IEC61850 has to offer to the customer's installations.

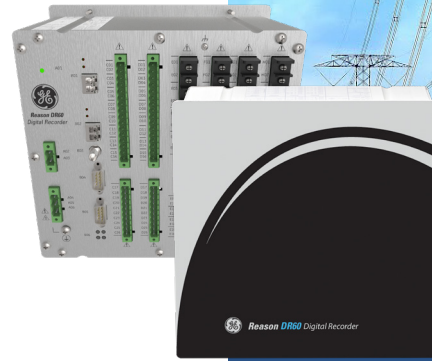

Situational Awareness

- Waveform recorder supporting 256 and 512 samples per cycle
- Disturbance and continuous disturbance recorder
- Trend Recorder & sequence of events recorder
- PMU IEEE C37.118.1/2-2011/1a-2014 compliance

High Density I/O

- Up to 32 analog inputs
- Up to 96 binary inputs and up to 48 binary outputs
- Up to 32 high-speed transducer inputs for HVDC applications

Communications

- Supporting industry standard protocols including DNP3, MMS and GOOSE
- Time synchronization including support for IEEE 1588 PTPv2 and IRIGB
- Serial (RS232 and Ethernet (RJ45 or LC) interfaces

Application Flexibility

- Cross triggering
- Trigger matrix for easy output configuration and special logic schemes
- Native configuration in SCL format
- MMS report control blocks
- Back and front panel mounting



Phasor Measurement Unit (PMU)

The DR60 provides powerful and cost-effective synchrophasor measurement solution according to IEEE C37.118.1/2-2011/1a-2014 standard and is capable of transmitting its data in up to 4 separate data streams. Each stream can be configurable independently based on: contents; frame rate; Class of service (P or M) and communication mode (TCP or UDP).

DR60 architecture example: DFR-Monitoring-PMU

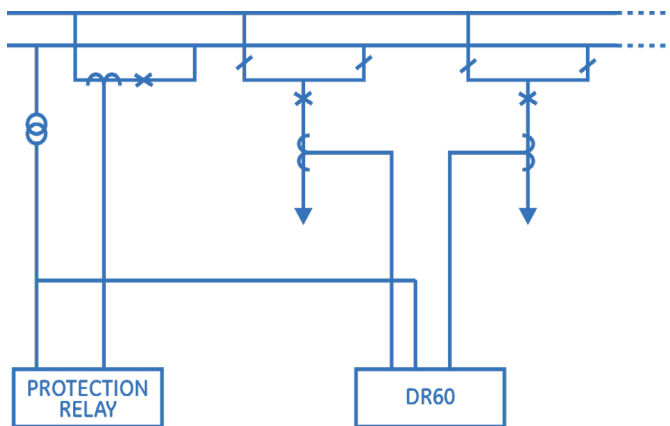

The DR60 can be installed to monitor and record analog and binary signals. Depending on the part number option, with a single DR60 it is possible to have: up to 32 analog inputs; up to 96 binary inputs; up to 32 high-speed transducer inputs for HVDC or up to 48 binary outputs.

DR60 architecture example: Extension I/O BOX

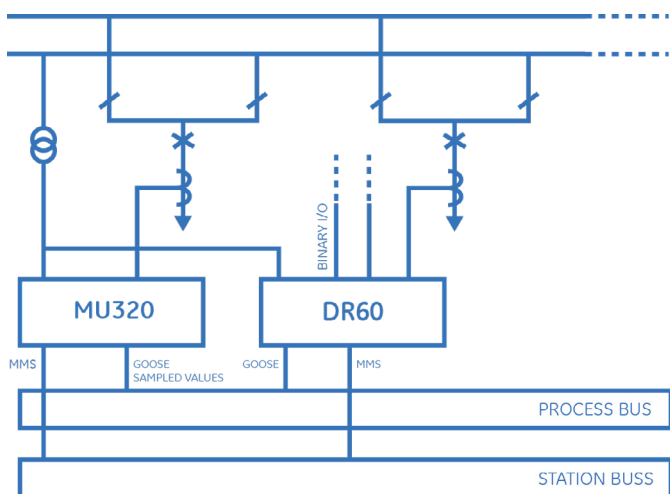

The DR60 can be used to translate the analog and binary signals into IEC 61850 standard protocol as GOOSE and MMS.

DC transducer inputs specifications

Characteristic	Voltage transducer input	Current transducer input
Dynamic range	- 12,5 to + 12,5 V	- 0 to 25 mA
Accuracy	± 0.1 % of FS	± 0.1 % of FS
Resistance	> 5 kΩ	10 Ω

Dimensions of the equipment

Height	222 mm / 8.7 in (5 U)
Width	222 mm / 8.7 in (½ 19")
Depth	121 mm / 4.7 in
Weight	< 3.5 kg (< 7.72 lb)

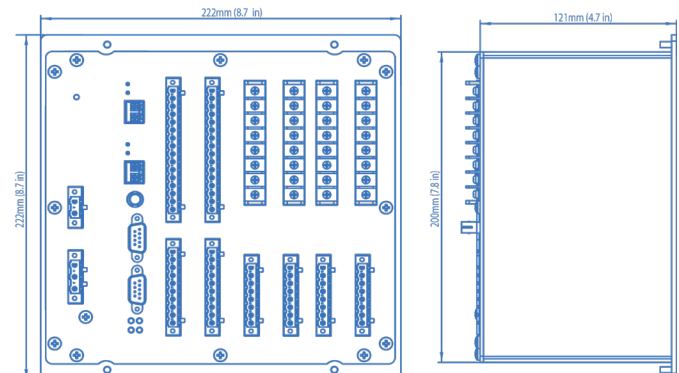

Ethernet ports

Type	Electrical	Optical
Use	Configuration, monitoring, Comms	Configuration, monitoring, Comms
Interface	10BASE-T / 100BASE-TX	100BASE-FX
Bit Rate	10 / 100 Mbps	100 Mbps
Connector	RJ 45	LC
Fiber type	---	multimode 62.5 / 125 μm
Wavelength	---	1300 nm
Emission power	---	-20 dBm
Sensitivity	---	-32 dBm
Maximum applicable power	---	-14 dBm
Isolation Level	1.44 KVdc	---

Serial port

Interface	RS232/485
Use	Device configuration, software upgrade, log download
Bitrate	1200, 2400, 4800, 9600, 19200, 38400 bps
Databits	7 or 8
Stopbits	1 or 2
Parity	None, even, odd
Connector	DB9 (female), standard DTE
Isolation Level	1.44 KVdc

IRIG-B optical port

Signal	IRIG-B004
Wavelength	820 nm
Fiber type	Multimode 62.5 / 125 μm
Connector	ST
Sensitivity	- 24 dBm

Binary inputs specifications

Nominal Voltage	125 / 250 Vdc	24 / 48 Vdc
Level Low	70 V	8 V
Level High	104 V	13 V
Impedance	120 kΩ	14 kΩ
Burden (Vn)	< 0.14W@125V < 0.65W@250V	< 0.06W@24V < 0.18W@48V
Continuous Overload ¹	300 V	100 V
Acquisition sampling rate	256 and 512 spc	256 and 512 spc

Binary outputs

Description	Dry contact relay, normally open
Switching Voltage	250 V (AC and DC)
Maximum continuous current	5 A
Maximum voltage	300 (AC and DC)
Making Capacity	15 A, 4 sec
Breaking Capacity	40 W Resistive 25 W/VA L/R = 50
Operation time	< 5 ms
Dropout time	< 15 ms
Burden	Per energized output relay: ~50mA @12V [600mW]
Withstand voltages across open contacts	1000V rms
Permissible short time value for 1s	30A

Current inputs specifications (50/60 Hz)

Characteristic	Standard input	Standard input	High Accuracy Inputs
Nominal Current (I _n)	1 A	5 A	1 and 5 A
Current range	0.02... 40 A	0.1... 200 A	0,005 to 10 A
Analog Input Accuracy	Class 0.5 (IEC 61869-2) <0,1% of full scale	Class 0.5 (IEC 61869-2) <0,1% of full scale	Class 0.1 (IEC 61869-2) <0,1% of full scale
Resistance	7,5 mΩ	1,5 mΩ	15 mΩ
Burden In	< 0.02 VA	< 0.05 VA	< 0.02 VA
Continuous overload (rms)	4 A (4 x I _n)	20 A (4 x I _n)	16 A
AC current thermal withstand (I _{th} rms for 1 sec)	100 A (100 x I _n)	320 A (64 x I _n)	20 A
Input isolation	> 3,5 kV	> 3,5 kV	> 3,5 kV

IN SERVICE contact specifications

Description	Dry contact relay, normally closed
Switching Voltage	250 V (AC and DC)
Permissible current continuous	5 A
Maximum voltage	300 (AC and DC)
Making Capacity	15 A, 4 sec
Breaking Capacity	40W Resistive, 25 W/VA L/R = 50
Dropout time	< 5 ms
Burden	~50mA @12V [600mW]
Withstand voltages across open contacts	1000V rms
Permissible short time value for 1s	30A

Voltage inputs specifications (50/60 Hz)

Characteristic	Standard input	High Accuracy Inputs
Nominal Voltage (V _n)	115 V	115 V
Voltage range RMS	0.25-460 V	0.11-230 V
Analog Input Accuracy	Class 0.5 (IEC 61869-2)	Class 0.1 (IEC 61869-2)
Impedance	> 210 kΩ	> 420 kΩ
Burden vn	< 0.1 VA	< 0.1 VA
Continuous Overload	230 V (2 x V _n)	230 V (2 x V _n)
MaximumOverload(1s)	460 V (4 x V _n)	460 V (4 x V _n)
Input isolation	> 3,5 kV	> 3,5 kV

Analog acquisition

System Frequency	Points per cycle	Acquisition Frequency	Bandwidth
50Hz	256PPC	12800Hz	from DC to 3150Hz
60Hz	256PPC	15360Hz	from DC to 3780Hz
50Hz	512PPC	25600Hz	from DC to 10000Hz
60Hz	512PPC	30720Hz	from DC to 10000Hz

Environmental tests

IEC 60068-2-1:	Operating and storage -40°C, 16 hours (Cold)
IEC 60068-2-2:	Operating +55°C, 16 hours (Dry heat) Storage +85°C, 16 hours (Dry heat)
IEC 60068-2-30	95% no condensation, 55°C (Damp heat)
IEC 60068-2-14	-40°C to 85°C / 9 hours / 2 cycles (Change of temperature)
IEC 60255-21-1	Class 2 (Vibration)
IEC 60255-21-2	Class 2 (Shock)

EMC tests according to IEC 60255-26

IEC 61000-4-2:2008 (Electrostatic discharge)	6kV contact / 8kV air (level 3)
IIEC 61000-4-3:2006 (RF immunity)	10 V/m (level 3)
IEC 61000-4-4:2012 (Fast transient disturbance)	Zone A 4kV / 5kHz
IEC 61000-4-5:2005 (Surge immunity)	Zone A Differential mode: 2 kV Common mode: 4 kV
IEC 61000-4-6:2008 (Conducted RF immunity)	0.15MHz to 80MHz 10V/rms
IEC 61000-4-8:2009 (Power magnetic immunity)	30A/m continuous - 300A/m @ 1s
IEC 61000-4-11:2004 IEC 61000-4-29:2000 (Voltage dip, short interruptions and voltage variation immunity tests)	- AC and DC voltage dips Test level: 0% residual voltage Duration time a.c.: 1 cycle d.c.: 16.6ms - Test level: 40% residual voltage Duration time a.c.: 12 cycle d.c.: 200ms - Test level: 70% residual voltage Duration time a.c.: 30 cycle d.c.: 500ms AC and DC voltage interruptions - Test level: 0% residual voltage Duration time a.c.: 300 cycles d.c.: 5s
IEC 61000-4-16:2009 (Conducted RF immunity, 0 to 150 kHz)	Zone A Test voltage Differential mode: 150 V rms Common mode: 300 V rms
IEC 61000-4-17:1999 (Voltage ripple)	Test level: 15 % of rated d.c. value Test frequency: 120Hz, sinusoidal waveform.
IEC 61000-4-18:2006 (Damped oscillatory wave immunity test)	Voltage oscillation frequency: 1MHz Differential mode: 1kV peak voltage; Common mode 2,5kV peak voltage Communication: Voltage oscillation frequency: 1MHz Differential mode: 0kV peak voltage; Common mode 1kV peak voltage
Gradual Startup	Shut-down ramp: 60s Power off: 5min Start-up ramp: 60s
CISPR11:2009 Radiated	Radiated emission below 1GHz class A 30 MHz to 230 MHz 40 dB(µV/m) quasi peak at 10 m 230 MHz to 1 000 MHz 47 dB(µV/m) quasi peak at 10 m

CISPR22:2009 Radiated	Radiated emission above 1GHz Class A 1 GHz to 3 GHz 56 dB(µV/m) Average 76 dB(µV/m) peak at 3m 3 GHz to 6 GHz 60 dB(µV/m) Average 80 dB(µV/m) peak at 3m
CISPR22:2009 Conducted	Class A 0,15 MHz to 0,50 MHz 79 dB(µV) quasi peak 66 dB(µV) average 0,5 MHz to 30 MHz 73 dB(µV) quasi peak 60 dB(µV) average

Environment conditions specification

Operating temperature range	-40 °C (-40 °F) ... +55°C (+131°F)
Tested as per IEC 60068-2-1:2013	-40°C (-40°F)
Tested as per IEC 60068-2-2:2013	+85°C (+185°F)
Relative humidity	0 ... 95 %, noncondensing
Enclosure Protection IEC 60529	IP20

Power supply specification

Operating nominal voltage	100-250 V dc, 110- 240 V ac	24-48 V dc
Frequency	50/60 Hz ± 3Hz	---
Operating voltage range	80 - 300 V dc, 88 - 264 V ac	18 -72 Vdc
Power Consumption	60VA @ 200mA	45W@ 700mA
Isolation Level	3.3 kVdc	3.3 kVdc

For more information please contact:

GE's Measurement & Networking Center of Excellence

Email: marketing.rtb@ge.com

Phone: +55 48 21080300

Worldwide Contact Centre

Web: www.GEGridSolutions.com/contact

Phone: +44 (0) 1785 250 070

GEGridSolutions.com

IEC is a registered trademark of Commission Electrotechnique Internationale. IEEE is a registered trademark of the Institute of Electrical Electronics Engineers, Inc. Modbus is a registered trademark of Schneider Automation. NERC is a registered trademark of North American Electric Reliability Council. NIST is a registered trademark of the National Institute of Standards and Technology.

GE, the GE monogram and Reason are trademarks of General Electric Company.

GE reserves the right to make changes to specifications of products described at any time without notice and without obligation to notify any person of such changes.

Copyright 2017, General Electric Company. All Rights Reserved.

English R002
1711



imagination at work