

# Multilin D30



## High-Speed Primary and Backup Distance Protection

The Multilin™ D30 is a cost-effective distance protection relay intended for protecting sub-transmission lines and underground cables of different voltage levels. Part of the Universal Relay (UR) family, the D30 comes with a variety of versatile features truly integrating protection, monitoring, metering, communication and control in one easy-to-use device.

### Key Benefits

- Cost-effective, high-speed, 5 zone quad or mho, phase and ground distance protection
- Application flexibility with programmable logic and multiple I/O options for customized pilot schemes
- Simplified teleprotection interfaces with direct I/O communications hardware for transfer trip and pilot-aided distance schemes
- Reduced relay-to-relay wiring and associated installation costs through high-speed inter-relay communications
- An integrated large, full color display, provides real-time visualization and control of the protected bay, via a bay mimic as well as annunciator functionality and graphical visualization of phasors
- Advanced IEC 61850 Ed. 1 and Ed. 2 certified implementation, complete settings via SCL files and comprehensive process bus support (IEC 61850-9-2LE or IEC 61869 or IEC 61850-9-2 Hardfiber) ensures interoperability, device managing optimization and reduced cost of ownership
- Routable GOOSE (R-GOOSE) enables GOOSE messages going beyond the substation, which enables wide area protection and control applications
- Increased network availability via failover time reduced to zero through IEC® 62439-3 “PRP” support
- Supports latest edition of waveform capture (COMTRADE 2013) simplifying fault records management

### Applications

- Overhead sub-transmission lines and underground cables including series compensated lines
- Circuits requiring three-pole autoreclosing and independent synchrocheck supervision
- Circuits with in-zone power transformers
- Secure application with Capacitively-Coupled Voltage Transformers (CCVTs)
- Backup protection for generators, transformers and reactors

## Protection & Control

- Phase & Ground distance (5 zones) with independent settings
- Out-of-step tripping and power swing blocking
- Line pickup, thermal protection, under/over frequency
- Four-shot autorecloser, VT fuse failure detection, and synchronism check
- Protection and control functionality in one box, reducing the number of devices
- High density inputs/outputs to support the control of many switchyard assets – all from one powerful device
- Integrated large, full color display, for real-time visualization and control of the protected bay

## Advanced Communications

- 3 independent Ethernet ports for simultaneous & dedicated network connections with IEEE 1588 support
- Direct I/O for secure, high-speed exchange of data for DTT & pilot-aided schemes
- IEC 61850-9-2LE/IEC 61869 networked or IEC61850-9-2 Hardfiber process bus support

## Cyber Security

- CyberSentry™ provides high-end cyber security aligned to industry standards and services (NERC® CIP, AAA, Radius, RBAC, Syslog)

## Monitoring & Metering

- Advanced recording capabilities with high-capacity event recorder, configurable and extended waveform capture and data logger
- Metering: current, voltage, power, energy, frequency



## Protection and Control

As part of the UR family of Protection & Control devices, the Multilin D30 offers a high degree of modularity in its design and functionality, providing superior performance while meeting the toughest requirements of the marketplace. Advanced protection and control features of this relay includes:

### Distance Protection

The core of the D30 relay is the distance function providing a high degree of sensitivity and selectivity for all types of faults. The D30 comes with five zones of phase distance and ground distance providing the user maximum flexibility to cater to different applications, including primary sub-transmission line protection and backup protection for busbars, EHV and HV transmission lines, generators, transformers and reactors. The relay can be applied to power systems with different earthing conditions, lines

## D30 - Protection, Metering, Monitoring and Control

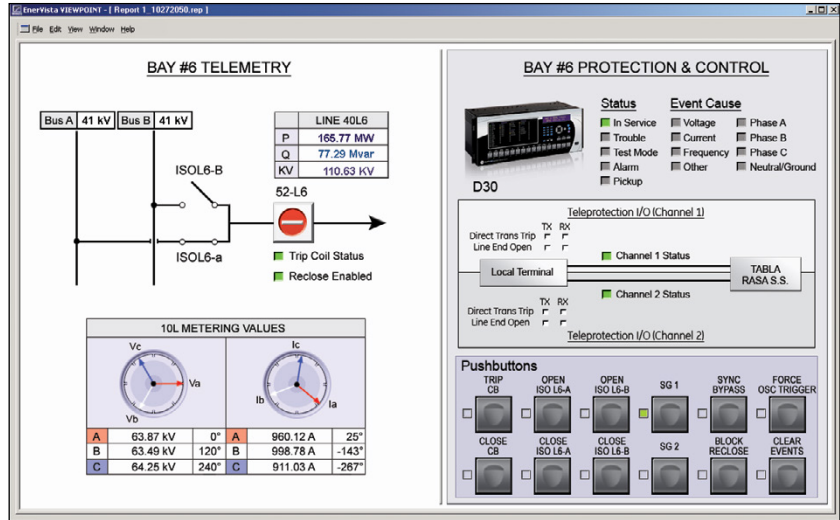

The D30 is the single point for protection, control, metering, and monitoring in one integrated device that can be easily connected directly to HMI or SCADA monitoring and control systems.

## Functional Block Diagram

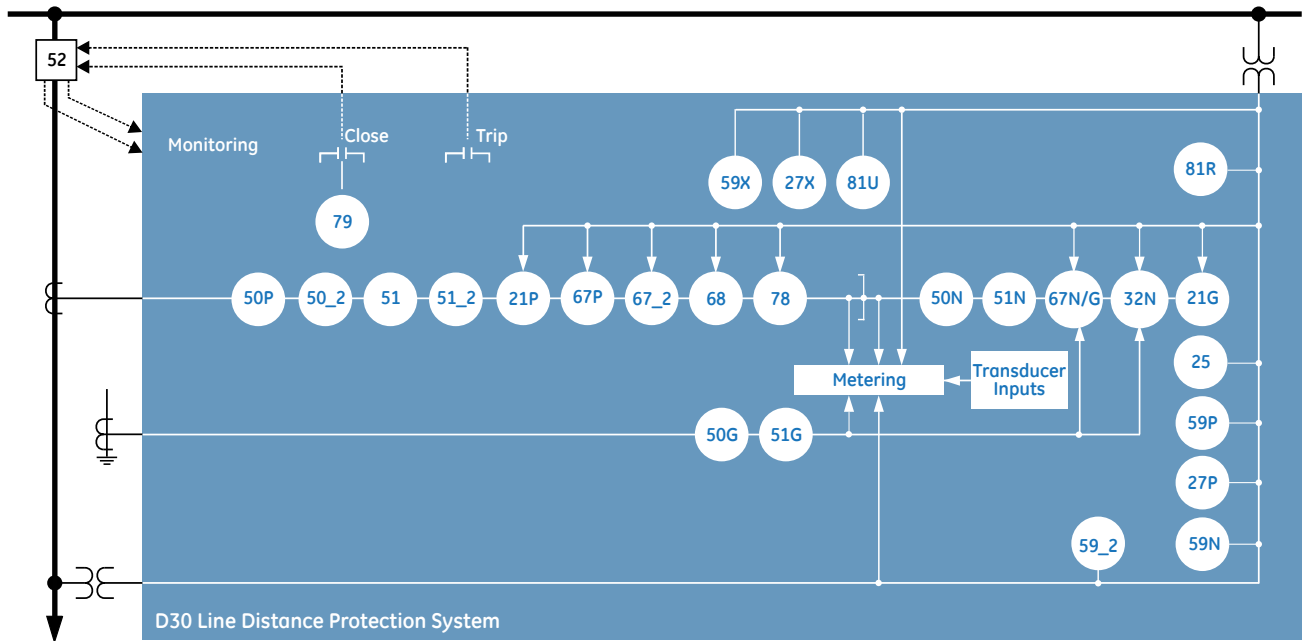

### ANSI® Device Numbers & Functions

DEVICE NUMBER	FUNCTION
21G	Ground Distance
21P	Phase Distance
25	Synchrocheck
27P	Phase Undervoltage
27X	Auxiliary Undervoltage
32N	Wattmetric Zero-Sequence Directional
49	Thermal Overload Protection
50DD	Current Disturbance Detector
50G	Ground Instantaneous Overcurrent
50N	Neutral Instantaneous Overcurrent

DEVICE NUMBER	FUNCTION
50P	Phase Instantaneous Overcurrent
50_2	Negative Sequence Instantaneous Overcurrent
51G	Ground Time Overcurrent
51N	Neutral Time Overcurrent
51P	Phase Time Overcurrent
51_2	Negative Sequence Time Overcurrent
52	AC Circuit Breaker
59N	Neutral Overvoltage
59P	Phase Overvoltage
59X	Auxiliary Overvoltage

DEVICE NUMBER	FUNCTION
59_2	Negative Sequence Overvoltage
67N	Neutral Directional Overcurrent
67P	Phase Directional Overcurrent
67_2	Negative Sequence Directional Overcurrent
68	Power Swing Blocking
78	Out-of-Step Tripping
79	Automatic Recloser
81R	Rate of change frequency
81U	Underfrequency
	Harmonic/Inrush detection

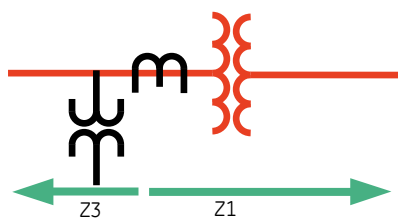

Z1 looking through a transformer.

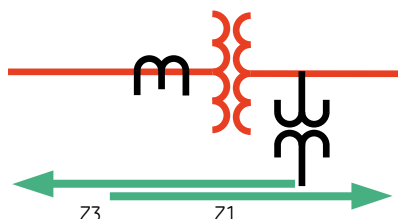

Z1 & Z3 looking through a transformer.

with in-zone transformers or tapped transformer feeders, and overhead lines with series compensation. Each zone element for the phase and ground distance can be independently set as quad or mho characteristics with the flexibility of designing different characteristic shapes to suit different power system conditions. The advanced comparator-based distance elements provide utmost security, sensitivity and selectivity for different types of faults. Superior digital filtering techniques provide secure and optimum reach accuracy even under worst-case CVT transients. Secure directional discrimination is achieved by using positive sequence memory voltage polarization providing reliable directionality for worst-case close-in faults. Dual distance algorithms deliver exceptional security and speed performance to ensure average operating times of 1.5 cycles for 75% line reach and SIR 30, and <2.5 cycles for 90% line reach and SIR 60. An additional voltage monitoring function provides extra security to the distance element, which can be used to block the distance elements under voltage source fuse failure conditions.

### In-Zone Transformer Compensation

Phase distance elements in the D30 can be used to detect faults through different types of three-phase wye/delta transformers allowing the application of the D30 for backup protection on generators. VTs and CTs can be installed independently on either side of the power transformer. The relay automatically compensates for transformer connections, to guarantee accurate reach for any type of fault.

### Load Encroachment

The load encroachment feature offers discrimination between line loading and fault conditions, especially for long lines under heavy loads by supervising the distance elements or any overcurrent element. This prevents unwanted tripping under heavy load conditions and enables optimum operation of the line while meeting regulatory requirements for line loading.

### Fault Locator

The integrated fault locator provides distance to fault in kilometers or miles. Parallel line zero-sequence current compensation and load current compensation enables the D30 to provide improved accuracy for fault distance measurement.

### Line Pickup (Switch-on-to-Fault)

The line pickup feature uses a combination of undercurrent and undervoltage to identify a line that has been de-energized (line end open). Three instantaneous overcurrent elements are used to identify a previously de-energized line that has been closed on to a fault.

### Power Swing Detection

Dynamic transients in the power system, due to short-circuits, circuit switching, or load changes, can travel across the power network as power swings characterized by fluctuating currents and voltages. This can result in unwanted tripping since distance elements can respond to these power swings as faults. The D30 swing detection element provides both power swing blocking and out-of-step tripping functions. The element measures the positive sequence

apparent impedance and traces its locus with respect to either a two or three-step user-selectable mho or quad operating characteristic. Negative sequence current supervisors provide extended selectivity for detecting evolving faults that may appear as a power swing event (faults with slow moving impedance locus).

### Overvoltage and Undervoltage Protection

Long lines under lightly loaded or no-load conditions may experience voltages exceeding the rated insulation voltage level of the line. Use the three phase overvoltage elements of the D30 to initiate a local trip as well as a remote trip using direct I/O. The D30 also provides additional voltage functions including neutral overvoltage, negative sequence overvoltage and phase undervoltage.

### Overcurrent Functions

The D30 provides thermal overload, time and instantaneous overcurrent elements for phase, neutral, ground, negative sequence, phase and neutral directional. All of them can run in parallel with distance elements or can be programmed to provide overcurrent protection under conditions when the distance element is blocked (Eg. VT fuse failure).

### Harmonic/Inrush detection

The Harmonic detection element monitors the selected 2nd to 5th harmonic or Total Harmonics Distortion (THD), which is present in the phase currents. The relay provides six identical Harmonic Detection elements.

During transformer energization or motor starts, the inrush current present in phase currents

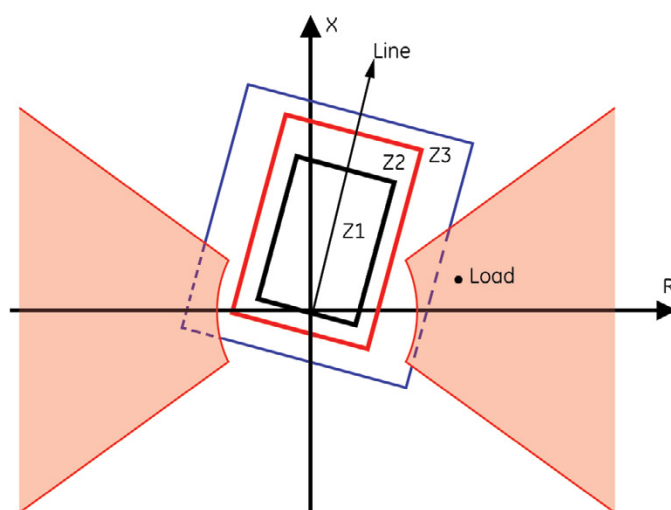

Distance relay quadrilateral characteristics supervised by the load encroachment function.

can impact some sensitive elements, such as negative sequence overcurrent. Therefore, the ratio of the second harmonic to the fundamental magnitude per phase is monitored, while exceeding the settable pickup level, an operand is asserted, which can be used to block such sensitive elements.

**Autorecloser**

The D30 provides multi-shot auto reclosing (up to 4 shots) for three-pole autoreclose on all types of faults with independent settings for each shot. The autoreclose element can be dynamically blocked or unblocked by other elements or user logic. This way they can be coordinated with the D30 protection setting groups.

**Synchronism Check**

The D30 provides six synchrocheck elements that monitor voltage difference, phase angle difference and slip frequency taking the CB closing time into account to ensure proper breaker closure as per user-defined settings. The D30 provides additional enhancements in synchronizing by checking dead source conditions for synchronism bypass under these conditions.

**IEC 61869 and 61850-9-2LE Process Bus**

Three UR process bus modules enable communicating to Merging Units “MU” that comply to either IEC 61869\* standard or IEC 61850-9-2LE technical report. MUs connect to the primary asset and translate analog signals and digital status/commands to standard sample values “SV” data and GOOSE messages.

Flexibility for connecting to different network size and topology is granted through 100Mbps and/ or 1Gbps Ethernet port support, plus IEC 62439 PRP or HSR standard redundancy, plus Star, Ring and Point-to-point network support.

For time synchronization purposes, this Process bus module can become an IEEE 1588 slave clock (61850-9-3 profile) or a 1588 Grand Master which removes the need of external time sources connected to the process bus network.

Customers who may not be using GE MU devices, could use MU from other vendors. Interoperability with MU from other vendors is expected when they comply to the mentioned standards.

**IEC 61850-9-2 HardFiber Process Bus**

The IEC 61850 Process Bus module is designed to interface with the Multilin HardFiber System, allowing bi-directional IEC 61850 fiber optic communications. The HardFiber System is designed to integrate seamlessly with existing UR applications, including protection functions, FlexLogic, metering and communications.

The Multilin HardFiber System offers the following benefits:

- Communicates using open standard IEC 61850 messaging
- Drastically reduces P&C design, installation and testing labor by eliminating individual copper terminations
- Integrates with existing D30's by replacing traditional CT/VT inputs with the IEC 61850 Process Bus module
- Does not introduce new cyber security concerns

Visit the HardFiber System product page on the Multilin web site for more details.

**Advanced Automation**

The D30 incorporates advanced automation features including powerful FlexLogic programmable logic, communication, and SCADA capabilities that far surpass what is

found in the average line protection relay used for subtransmission. The D30 integrates seamlessly with other UR relays for complete system protection.

**FlexLogic**

FlexLogic is the powerful UR-platform programming logic engine that provides the ability to create customized protection and control schemes, minimizing the need and associated costs of auxiliary components and wiring. With 1024 lines of FlexLogic, the D30 can be programmed to provide the required tripping logic along with custom scheme logic for breaker control (including interlocking), transfer tripping schemes for remote breakers and dynamic setting group changes.

**Scalable Hardware**

The D30 is available with a multitude of I/O configurations to suit the most demanding application needs. The expandable modular design allows for easy configuration and future upgrades.

- Flexible, modular high density I/O covering a broad range of input signals and tripping schemes
- Types of digital outputs include trip-rated Form-A and Solid State Relay (SSR) mechanically latching, and Form-C outputs

**Topologies:**

PRP Start  
Hot-Stanby

**Topologies:**

HSR ring  
PRP start  
P-2-P Process Bus

Merging units

Conventional or Optical CT/VTs

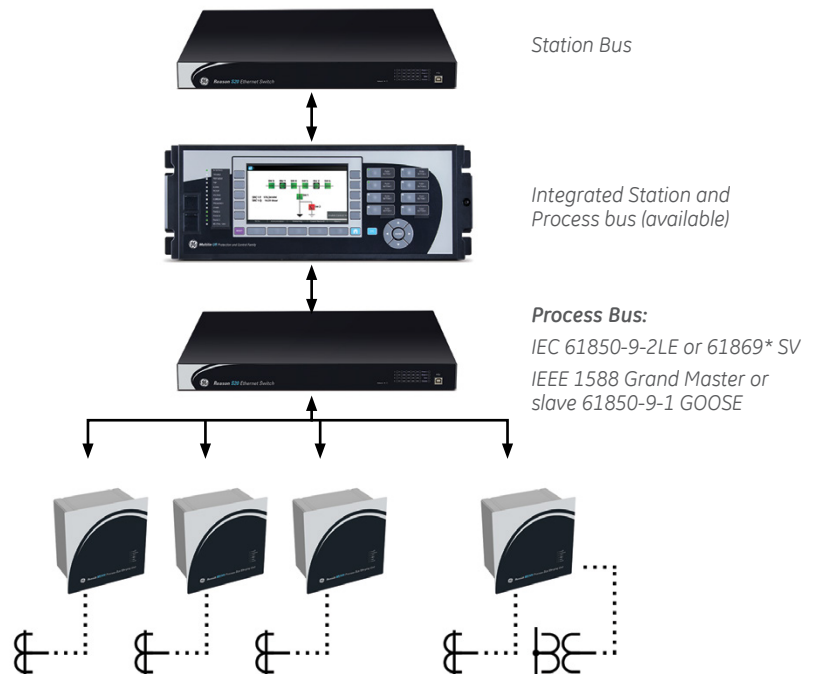



- Form-A and SSR outputs available with optional circuit continuity monitoring and current detection to verify continuity and health of the associated circuitry
- Mechanically latching outputs can be used to develop secure interlocking applications and replace electromechanical lockout relays

## Monitoring and Metering

The D30 includes high accuracy metering and recording for all AC signals. Voltage, current, and power metering are built into the relay as a standard feature. Current and voltage parameters are available as total RMS magnitude, and as fundamental frequency magnitude and angle.

## Fault and Disturbance Recording

The advanced disturbance and event recording features within the D30 can significantly reduce the time needed for postmortem analysis of power system events and the creation of regulatory reports. Recording functions include:

- Sequence of Event (SOE)
  - 1024 time stamped events
- Oscillography
  - Supports IEEE C37.111-1999/2013, IEC 60255-24 Ed 2.0 COMTRADE standard
  - 128 digital & up to 56 analog channels
  - Events with up to 45s length
- Data Logger and Disturbance Recording
  - 16 channels up to 1 sample/cycle/channel
- Fault Reports
  - Powerful summary report of pre-fault and fault values

The very high sampling rate and large amount of storage space available for data recording in the D30 can eliminate the need for installing costly stand-alone recording equipment.

## Advanced Device Health Diagnostics

The D30 performs comprehensive device health diagnostic tests at startup and continuously during run-time to test its own major functions and critical hardware. These diagnostic tests monitor for conditions that could impact security and availability of protection, and present device status via SCADA communications and front panel display. Providing continuous monitoring and early detection of possible issues help improve system uptime.

- Comprehensive device health diagnostic performed at startup
- Monitors the CT/VT input circuitry to validate the integrity of all signals

## Substation Monitoring

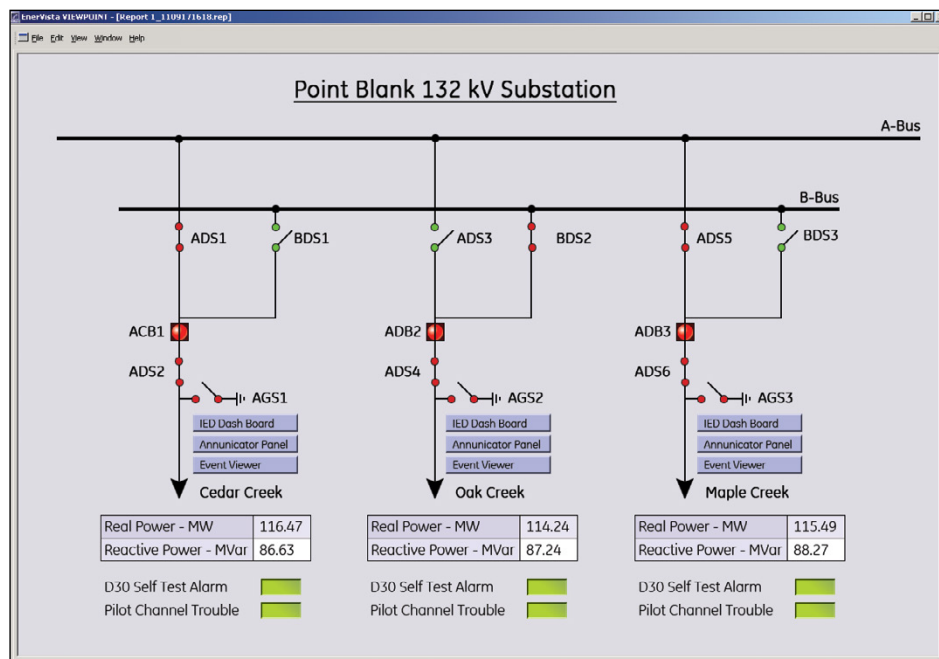

Monitor the status of your substation using the easy to use Viewpoint Monitoring HMI.

## Cyber Security – CyberSentry UR

CyberSentry UR enabled UR devices deliver full cyber security features that help customers to comply with NERC CIP and NIST@ IR 7628 cyber security requirements.

This software option delivers the following core features:

### AAA Server Support (Radius/LDAP)

Enables integration with centrally managed authentication and accounting of all user activities and uses modern industry best practices and standards that meet and exceed NERC CIP requirements for authentication and password management.

### Role Based Access Control (RBAC)

Efficiently administrate users and roles within UR devices. The new and advanced access functions allow users to configure up to five roles for up to eight configurable users with independent passwords. The standard "Remote Authentication Dial In User Service" (Radius) is used for authentication.

### Event Recorder (Syslog for SEM)

Capture all cyber security related events within a SOE element (login, logout, invalid password attempts, remote/local access, user in session, settings change, FW update, etc), and then serve and classify data by security level using

standard Syslog data format. This will enable integration with established SEM (Security Event Management) systems.

## Communications

The D30 provides advanced communications technologies for remote data and engineering access, making it easy and flexible to use and integrate into new and existing infrastructures. Direct support for fiber optic Ethernet provides high-bandwidth communications allowing for low-latency controls and high-speed file transfers of relay fault and event record information. The available three independent Ethernet ports, redundant Ethernet option and the embedded managed Ethernet switch provide the means to create fault tolerant communication architectures in an easy, cost-effective manner.

The D30 supports the most popular industry standard protocols enabling easy, direct integration into monitoring and SCADA systems.

- IEC 61850 Ed. 1 and Ed. 2 Station Bus, IEC 61850-2-2LE / IEC 61869 networked or IEC 61850-9-2 HardFiber Process Bus
- DNP 3.0 (serial & TCP/IP)
- Ethernet Global Data (EGD)
- IEC 60870-5-103 and IEC 60870-5-104
- Modbus RTU, Modbus TCP/IP

- HTTP, TFTP, SFTP and MMS file transfer
- IEEE1588 and redundant SNTP for time synchronization
- PRP as per IEC 62439-3
- Supports Routable GOOSE (R-GOOSE)

**Interoperability with Embedded IEC 61850 Ed. 1 and Ed. 2**

The new IEC 61850 implementation in the UR Family positions GE as an industry leader in this standard.

- Implements, user selectable, Ed. 1 and Ed. 2 of the standard across the entire UR Family
- Provides full relay setting management via standard SCL files (ICD, CID and IID)
- Enables automated relay setting management using 3rd party tools through standard file transfer services (MMS and SFTP)
- Increases the number of Logical Devices and data mapped to them, GOOSE messages from/to up to 64 remote devices, and reports to support different organizational needs for data transfer and reduce dependency on generic logical nodes
- Configures GE Systems based on IEC 61850 using universal 3rd party tools
- R-GOOSE enable customer to send GOOSE messages beyond the substation, which

enables WAPC and more cost effective communication architectures for wide area applications

**Direct I/O Messaging**

Direct I/O allows for the sharing of high-speed digital information between multiple UR relays via direct back-to-back connections or multiplexed through a standard D50 multiplexer channel bank. Regardless of the connection method, direct I/O provides continuous real-time channel monitoring that supplies diagnostics information on channel health.

Direct I/O provides superior relay-to-relay communications that can be used in advanced interlocking, and other special protection schemes.

- Communication with up to 16 UR relays in single or redundant rings rather than strictly limited to simplistic point-to-point configurations between two devices
- Connect to standard D50 channel banks through standard RS422, G.703 or IEEE C37.94 interfaces or via direct fiber optic connections
- No external or handheld tester required to provide channel diagnostic information

**LAN Redundancy**

Substation LAN redundancy has been traditionally accomplished by reconfiguring the active network topology in case of failure. Regardless of the type of LAN architecture (tree, mesh, etc), reconfiguring the active LAN requires time to switchover, during which the LAN is unavailable. UR devices deliver redundancy as specified by PRP-IEC 62439-3, which eliminates the dependency on LAN reconfiguration and the associated switchover time. The UR becomes a dual attached node that transmits data packets over both main and redundant networks simultaneously, so in case of failure, one of the data packets will reach the receiving device with no time delay.

**Multi-Language**

UR devices support multiple languages: English, French, Russian, Chinese, Turkish, German, Polish and Japanese. These language options are available on the front panel, in the EnerVista setup software, and in the product manuals. Easily switch between English and an additional language on the local displays without uploading new firmware.

**Power System Troubleshooting**

The D30 contains many tools and reports that simplify and reduce the amount of time required for troubleshooting power system events.

CHANEL IDENTIFIER	COLOR	GROUP	MAGNITUDE / ANGLE
F1a	Blue	Group 1	8.15 A -350.52 deg
F2a	Green	Group 1	0.00 A -314.25 deg
F3a	Red	Group 1	0.00 A -134.25 deg
F4a	Yellow	Group 1	8.05 A -293.98 deg
F5-VA	Blue	Group 1	63469.05 V 0.00 deg
F5-VB	Green	Group 1	103675.04 V -119.95 deg
F5-VC	Red	None	

Event Number	Date/Time	Cause
24752262	Sep 29 2008 01:38:40.87198	SPR2 V FFF VOL LOSS
24752261	Sep 29 2008 01:38:41.86998	SPR2 V FFF VOL LOSS
24752230	Sep 30 2008 18:02:30.822438	SPR2 V FFF VOL LOSS
24752229	Sep 29 2008 08:15:34.846218	SPR2 V FFF VOL LOSS
24752227	Sep 29 2008 08:15:33.717687	ICCD24R BRNG ARMED
24752280	Sep 29 2008 08:15:05.870181	DLK ON
24752281	Sep 29 2008 08:14:58.870277	DLK ON
24752034	Sep 29 2008 08:14:28.384442	TRIG OSC OFF
24752253	Sep 29 2008 08:14:24.381899	OSCOLLOGRAPHY TRIGD
24752252	Sep 29 2008 08:14:24.381898	TRIG OSC ON
24752231	Sep 29 2008 08:14:24.380698	EXT TRIG OSC OFF
24752281	Sep 29 2008 08:14:24.378193	EXT TRIG OSC ON
24752229	Sep 29 2008 08:14:24.384418	TRIG OSC OFF
24752280	Sep 29 2008 08:14:24.381917	OSCOLLOGRAPHY TRIGD
24752227	Sep 29 2008 08:14:24.380692	EXT TRIG OSC ON
24752226	Sep 29 2008 08:14:24.380693	EXT TRIG OSC ON
24752224	Sep 29 2008 08:14:23.390350	TRIG OSC OFF
24752223	Sep 29 2008 08:14:23.390350	OSCOLLOGRAPHY TRIGD
24752222	Sep 29 2008 08:14:23.390350	EXT TRIG OSC ON
24752221	Sep 29 2008 08:14:23.390350	EXT TRIG OSC OFF

Analyze transmission line faults using system voltage, current and appropriate pickup flags that are measured & recorded up to 64 samples/cycle.

Graphically view zone settings for ground & phase distance elements for the selected zones.

Record the operation of the internal D30 elements and external connected devices with 1ms time-stamped accuracy to identify the Sequence of Operation of station devices during faults and disturbances.

## EnerVista Software

The EnerVista suite is an industry-leading set of software programs that simplifies every aspect of using the D30 relay. The EnerVista suite provides all the tools to monitor the status of the protected asset, maintain the relay, and integrate information measured by the D30 into DCS or SCADA monitoring systems. Convenient COMTRADE and SOE viewers are an integral part of the UR setup software included with every UR relay, to carry out postmortem event analysis and ensure proper protection system operation.

### EnerVista Launchpad

EnerVista Launchpad is a powerful software package that provides users with all of the setup and support tools needed for configuring and maintaining Multilin products. The setup software within Launchpad allows for the configuration of devices in real-time by communicating using serial, Ethernet, or modem connections, or offline by creating setting files to be sent to devices at a later time. Included in Launchpad is a document archiving and management system that ensures critical documentation is up-to-date and available when needed. Documents made available include:

- Manuals
- Application Notes
- Guideform Specifications
- Brochures
- Wiring Diagrams
- FAQ's
- Service Bulletins

### Viewpoint Monitoring

Viewpoint Monitoring is a simple-to-use and full-featured monitoring and data recording software package for small systems. Viewpoint Monitoring provides a complete HMI package with the following functionality:

- Plug-&-Play Device Monitoring
- System Single-Line Monitoring & Control
- Annunciator Alarm Screens
- Trending Reports
- Automatic Event Retrieval
- Automatic Waveform Retrieval

### Viewpoint UR Engineer

Viewpoint UR Engineer is a set of powerful tools that allows the configuration and testing of GE relays at a system level in an easy-to-use graphical drag-and-drop environment. Viewpoint UR Engineer provides the following configuration and commissioning utilities:

- Graphical Logic Designer
- Graphical System Designer
- Graphical Logic Monitor
- Graphical System Monitor

### Viewpoint Maintenance

Viewpoint Maintenance provides tools that will create reports on the operating status of the relay, simplify the steps to download fault and event data, and reduce the work required for cyber security compliance audits. Tools available in Viewpoint Maintenance include:

- Settings Security Audit Report
- Device Health Report
- Single-Click Fault Data Retrieval

### EnerVista Integrator

EnerVista Integrator is a toolkit that allows seamless integration of Multilin devices into new or existing automation systems. Included in EnerVista Integrator is:

- OPC/DDE Server
- Multilin Drivers
- Automatic Event Retrieval
- Automatic Waveform Retrieval

## User Interface

The D30 front panel provides extensive local HMI capabilities. The local display is used for monitoring, status messaging, fault diagnosis, and device configuration. User-configurable messages that combine text with live data can be displayed when user-defined conditions are met.

A 7" color, graphic HMI is optionally available that allows users to have customizable bay diagrams with local monitoring of status, values and control functionality. The alarm annunciator panel provides the configuration of up to 96 signals (alarms and status) with full text description.

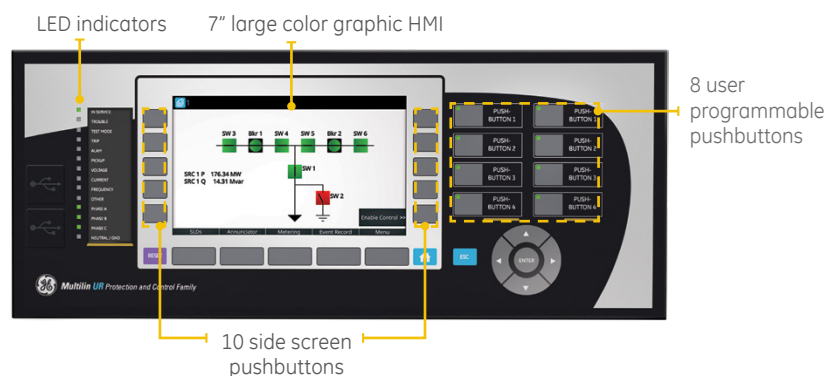

Typical Wiring

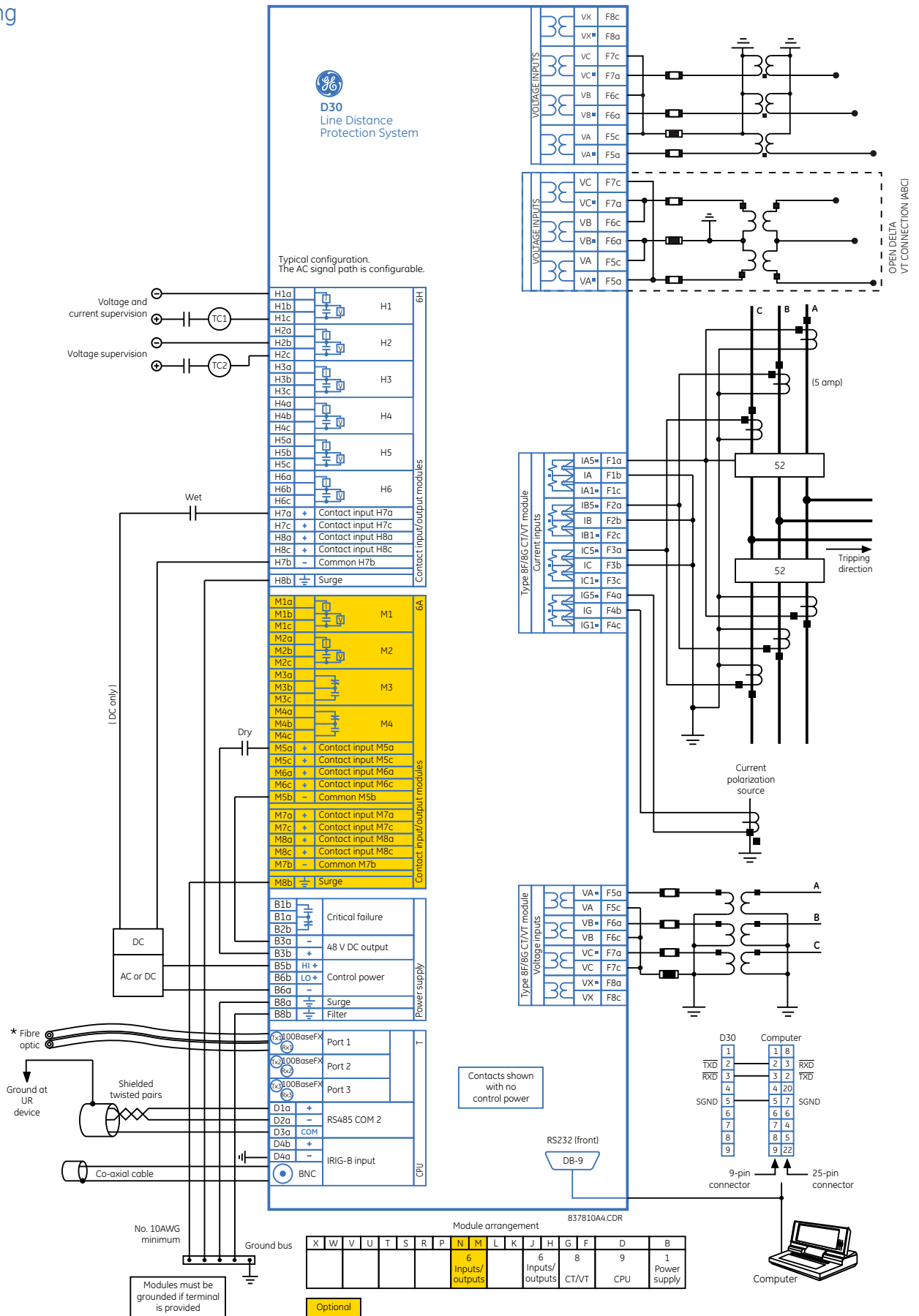



# Ordering

	D30	-	*	**	-	H	*	*	-	F**	-	H**	-	M**	-	P**	-	U**	-	W**	For Full Sized Horizontal Mount				
Base Unit	D30																				Base Unit				
CPU		E	J	K	N	T	U	V	W												RS485 + RS485 (IEC 61850 option not available) RS485 + Multimode ST 100BaseFX RS485 + Multimode ST Redundant 100BaseFX RS485 + 10/100 BaseT RS485 + three Multimode SFP LC 100BaseFX. Req FW v7xx or higher RS485 + two Multimode SFP LC 100BaseFX + one SFP RJ45 100BaseT. Req FW v7xx or higher RS485 + three SFP RJ45 100BaseT. Req FW v7xx or higher RS485 + two 100BaseFx Eth, Multimode ST + one 10/100BaseT Eth, RJ-45 <sup>3</sup>				
Software Options <sup>1</sup>		00	03	A0	B0	CO	DO														No Software Options IEC 61850 CyberSentry UR Lvl 1. Req UR FW 7.xx or higher IEEE 1588. Req UR FW 7.xx or higher PRP IEEE 1588 + CyberSentry. Req UR FW 7.xx or higher				
Mount						H	A	V	B												Horizontal (19" rack) - Standard Horizontal (19" rack) - Harsh Chemical Environment Option Vertical (3/4 size) - Standard Vertical (3/4 size) - Harsh Chemical Environment Option				
User Interface							E	F	I	J	K	L	M	N	O	T	U	V	W	Y	H	O	Z	X	7" Graphical display, USB front port & programmable pushbuttons - Multi-Language (FW 7.6x or higher) Vertical Front Panel with English Display Enhanced German Front Panel Enhanced German Front Panel with User-Programmable Pushbuttons Enhanced English Front Panel Enhanced English Front Panel with User-Programmable Pushbuttons Enhanced French Front Panel Enhanced French Front Panel with User-Programmable Pushbuttons Enhanced Russian Front Panel Enhanced Russian Front Panel with User-Programmable Pushbuttons Enhanced Chinese Front Panel Enhanced Chinese Front Panel with User-Programmable Pushbuttons Enhanced Turkish Front Panel Enhanced Turkish Front Panel with User-Programmable Pushbuttons Enhanced Polish Front Panel <sup>3</sup> Enhanced Polish Front Panel with User-Programmable Pushbuttons <sup>3</sup> Enhanced Japanese Front Panel <sup>3</sup> Enhanced Japanese Front Panel with User-Programmable Pushbuttons <sup>3</sup>
Power Supply <sup>2</sup>						H	L														RH	125 / 250 V AC/DC 125/250 V AC/DC with redundant 125/250 V AC/DC power supply 24 - 48 V (DC only)			
CT/VT DSP										8L	8M											Standard 4CT/4VT w/ enhanced diagnostics Sensitive Ground 4CT/4VT w/ enhanced diagnostics			
IEC 61850 Process Bus <sup>4,5</sup>																						8 Port IEC 61850 Process Bus Module -9-2LE & 61869 Process Bus, 2 x 1000BaseF -9-2LE & 61869 Process Bus, 4 x 1000BaseF + 4 x 100BaseFx -9-2LE & 61869 Process Bus, 4 x 100BaseFx			
Digital I/O																						No module 4 Solid State (No Monitoring) MOSFET Outputs 4 Solid State (Current w/opt Voltage) MOSFET Outputs 16 Digital Inputs with Auto-Burnish 14 Form-A (No Monitoring) Latchable Outputs 8 Form-A (No Monitoring) Outputs 8 Form-C Outputs 16 Digital Inputs 4 Form-C Outputs, 8 Digital Inputs 8 Fast Form-C Outputs 4 Form-C & 4 Fast Form-C Outputs 2 Form-A (Current w/ opt Voltage) & 2 Form-C Outputs, 8 Digital Inputs 2 Form-A (Current w/ opt Voltage) & 4 Form-C Outputs, 4 Digital Inputs 4 Form-A (Current w/ opt Voltage) Outputs, 8 Digital Inputs 6 Form-A (Current w/ opt Voltage) Outputs, 4 Digital Inputs 2 Form-A (No Monitoring) & 2 Form-C Outputs, 8 Digital Inputs 2 Form-A (No Monitoring) & 4 Form-C Outputs, 4 Digital Inputs 4 Form-A (No Monitoring) Outputs, 8 Digital Inputs 6 Form-A (No Monitoring) Outputs, 4 Digital Inputs 2 Form-A (Cur w/ opt Volt) 1 Form-C Output, 2 Latching Outputs, 8 Digital Inputs 30 Contact Inputs - Pin Terminals <sup>3</sup> 18 Form-A (No Monitoring) Outputs - Pin Terminals <sup>3</sup>			
Transducer I/O																						4 dcmA Inputs, 4 dcmA Outputs 8 dcmA Inputs			
Inter-Relay Communications																						IEEE C37.94SM, 1300nm singlemode, ELED, 2 Channel singlemode Channel 1 - IEEE C37.94, 820nm, multimode fiber, 64/128 kbps; Channel 2 - 1300 nm, singlemode, LASER Channel 1 - IEEE C37.94, 820nm, multimode fiber, 64/128 kbps; Channel 2 - 1550 nm, single mode, LASER 820 nm, multimode, LED, 1 Channel 1300 nm, multimode, LED, 1 Channel 1300 nm, singlemode, ELED, 1 Channel 820 nm, multimode, LED, 2 Channels 1300 nm, multimode, LED, 2 Channels 1300 nm, singlemode, ELED, 2 Channels G.703, 2 Channels RS422, 2 Channels 1550 nm, singlemode, LASER, 2 Channels IEEE C37.94, 820 nm, multimode, LED, 2 Channel			

## Ordering Note:

- To view all the options available for D30, please visit GE's On-Line Store <http://store.gedigitalenergy.com/viewprod.asp?model=D30>
- Redundant power supply only available in horizontal unit. If redundant is chosen, must be same type. Maximum 2 per chassis
- Option available soon
- Process bus module requires empty slots next to it.
- Conventional DSP and Process Bus modules cannot run simultaneously

## GEGridSolutions.com

IEC is a registered trademark of Commission Electrotechnique Internationale. IEEE is a registered trademark of the Institute of Electrical Electronics Engineers, Inc. Modbus is a registered trademark of Schneider Automation. NERC is a registered trademark of North American Electric Reliability Council. NIST is a registered trademark of the National Institute of Standards and Technology.

GE, the GE monogram, MultiIli, FlexLogic, EnerVista and CyberSentry are trademarks of General Electric Company.

GE reserves the right to make changes to specifications of products described at any time without notice and without obligation to notify any person of such changes.

Copyright 2020, General Electric Company.

GEA-12593LIEN  
English  
200722

