

Multilin C70



Capacitor Bank Protection & Control

The Multilin™ C70 is an integrated protection, control, and monitoring device for shunt capacitor banks based on the well established and proven Multilin Universal Relay (UR) platform. The C70 provides both the bank and system protection schemes for shunt capacitor bank protection. The current and voltage-based protection functions are designed to provide sensitive protection for grounded, ungrounded single, and parallel capacitor banks and banks with taps, for a variety of capacitor bank configurations. The sophisticated built-in control functions can be used to automate capacitor switching with ease and flexibility for automatic voltage regulation of the system.

In addition, the C70 comes with a variety of versatile features truly integrating protection, monitoring, metering, communication and control in one easy-to-use device.

Key Benefits

- Comprehensive capacitor bank protection for a variety of configurations with sensitive current and voltage balance protection functions
- Adaptive compensation techniques truly compensate for the inherent bank unbalance, providing sensitive protection
- Custom programmable logic for advanced shunt capacity bank controls
- Flexible automatic voltage regulation of shunt capacitor banks along with control supervision
- An integrated large, full color display, provides real-time visualization and control of the protected bay, via a bay mimic as well as annunciator functionality and graphical visualization of phasors
- Advanced IEC 61850 Ed. 1 and Ed. 2 certified implementation, complete settings via SCL files and comprehensive process bus support (IEC 61850-9-2LE or IEC 61869* or IEC 61850-9-2 Hardfiber) ensures interoperability, device managing optimization and reduced cost of ownership
- Routable GOOSE (R-GOOSE) enables customer to send GOOSE messages beyond the substation, which enables WAPC and more cost effective communication architectures for wide area applications
- Increased network availability via failover time reduced to zero through IEC® 62439-3 "PRP" support
- Supports IEEE C37.111-1999/2013, IEC 60255-24 Ed 2.0 COMTRADE standard

Applications

- Protection, control, monitoring and automation of shunt capacitor banks at different voltage levels
- Sensitive protection for grounded and ungrounded single and parallel capacitor banks and banks with taps, for a variety of capacitor bank configurations
- Suitable for protecting multiple capacitor banks
- Capacitor bank-based automatic voltage regulator (AVR) and capacitor control supervision

Protection and Control

- Voltage differential protection and compensated bank neutral voltage unbalance
- AVR for switching capacitor banks based on voltage, power factor and reactive power
- Time and date function allowing capacitor bank switching, based on time of day, week and seasons
- Capacitor control supervision block for processing commands from SCADA, remote communication and local control through front panel HMI
- Protection and control functionality in one box, reducing the number of devices
- High density inputs/outputs to support the control of many switchyard assets – all from one powerful device
- Integrated large, full color display, for real-time visualization and control of the protected bay

Advanced Communications

- 3 independent Ethernet ports for simultaneous & dedicated network connections with IEEE 1588 support
- IEC 61850-9-2LE/IEC 61869* networked or IEC61850-9-2 Hardfiber process bus support

Cyber Security

- CyberSentry™ provides high-end cyber security aligned to industry standards and services (NERC® CIP, AAA, Radius, RBAC, Syslog)

Monitoring & Metering

- Advanced recording capabilities with high-capacity event recorder, configurable and extended waveform capture and data logger
- Metering: current, voltage, power, energy, frequency, and harmonics



Introduction

Part of the Multilin UR family of Protection & Control devices, the Multilin C70 Capacitor Bank Protection and Control System offers a high degree of modularity in its design and functionality, providing superior performance while meeting the toughest requirements of the marketplace. Coupled with the unparalleled EnerVista software toolsets, common architecture and user-friendly interfaces helps managing the relay and the power system in the easiest way.

Advanced protection and control features of the Multilin C70 Capacitor Bank Protection and Control System includes:

Protection

C70 provides sensitive protection functions designed specifically to protect the shunt capacitor banks effectively. The C70 provides current-based protection functions, which include phase, ground, and neutral instantaneous and time overcurrent elements for standard overcurrent protection of the bank. Two elements per configured CT bank are available.

The standard current-based protection functions include:

- Phase instantaneous overcurrent (50P)
- Phase time overcurrent (51P)
- Phase directional (67P)
- Thermal overload (49)
- Ground instantaneous overcurrent (50G)
- Ground time overcurrent (51G)
- Neutral instantaneous overcurrent (50N)
- Neutral time overcurrent (51N)
- Neutral directional overcurrent with dual polarity criteria (67N)
- Negative sequence instantaneous overcurrent (50_2)
- Negative sequence time overcurrent (51_2)
- Negative sequence directional overcurrent (67_2)

The C70 also provides breaker failure protections and standard voltage-based protection functions which include:

- Phase overvoltage (59P)
- Phase undervoltage (27P)
- Auxiliary overvoltage (59X)
- Neutral overvoltage (59N)
- Negative sequence undervoltage (27N)

Apart from the standard current and voltage-based functions, the C70 comes with protection functions specifically designed to provide sensitive protection for capacitor banks in a single box. Typical configurations with their associated model numbers are shown.

Voltage Differential

- Applicable for both grounded and ungrounded banks. In the ungrounded case, the algorithm uses the neutral point voltage to provide sensitive protection.
- Based on a simple voltage divider principle, which compares the bus voltage with the tap voltage of the bank.
- Three-phase element with four independent stages for alarming and control. Each stage has independent per-phase settings and a common time delay.
- Provision to set the per-phase voltage divider factors manually, or by selecting the auto-setting feature. The voltage divider factor can be calculated automatically under user supervision either locally or remotely.
- One voltage differential element provided per VT bank up to a maximum of three.

Compensated Bank Neutral Voltage Unbalance

- Applicable to ungrounded banks.
- Truly compensates for both the system unbalance and the bank unbalance.
- Each element has four independent stages; each stage has an independent threshold, restraint slope, and time delay.
- Provisions to set the inherent bank unbalance factors manually, or by selecting the auto-setting feature. The bank unbalance factor can be calculated automatically under user supervision either locally or remotely.

Bank Phase Overvoltage

- Applicable for both grounded and ungrounded banks. In the latter case the relay takes the neutral point voltage in order to derive the voltage drop across the capacitor strings.
- Three-phase elements with three definite time stages and three inverse time stages.
- One bank overvoltage element provided per VT bank up to a maximum of three.

Phase Current Unbalance

- Based on the balance between phase currents of two parallel banks and is applicable to both grounded and ungrounded banks.
- SCompensates for bank unbalances to provide better sensitivity.

- Three-phase element with four independent stages for protection and alarming. Each stage has independent per-phase settings and a common time delay.
- Provision to set the current divider factor individually, per-phase, manually, or by selecting the auto-setting feature. The current divider factor can be calculated automatically under user supervision either locally or remotely.
- Immune to system transients, providing secure operation without resorting to any excessive filtering.
- One phase current unbalance element is provided per CT/VT module up to a maximum of three.

Neutral Current Unbalance

- Based on the balance between the interconnected neutral current of two parallel banks and is applicable to both grounded and ungrounded banks.
- Grounded banks require a window CT.
- Each element has four independent stages; each stage has independent threshold and time delay settings.
- Provision to set the bank unbalance factors manually, or by selecting the auto-setting feature. The bank unbalance factor can be calculated automatically under user supervision either locally or remotely.
- One neutral current unbalance element provided per CT/VT module, up to a maximum of three.

Control

The C70 is provided with built-in control functions to help end users build capacitor bank control schemes of their choice with ease and flexibility.

Automatic Voltage Regulator

The AVR is a capacitor bank controller responding to either voltage, reactive power, or power factor. One AVR element is provided per CT/VT module, up to a maximum of three. The AVRs can operate independently, each on their own section of the bank, or on only the one set for present conditions/time-of-day, as determined by FlexLogic™ (user programmable logic). For the voltage control path, a provision is made to operate from any phase-phase voltage (VAB, VBC, VCA), average voltage (VAVER), positive-sequence voltage (V1) or the single-phase auxiliary voltage. Two applications using the reactive power/power factor path are shown below.

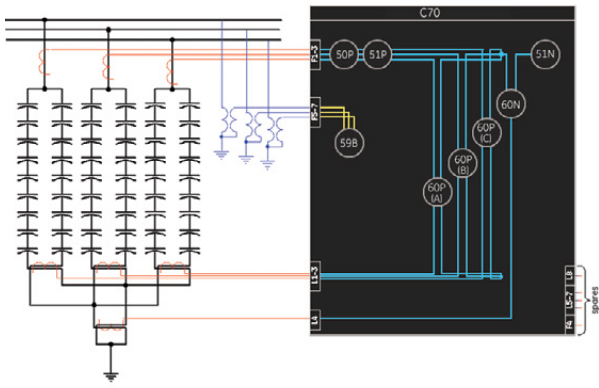

Typical Application: Grounded, parallel banks

Typical Model No: C70-N03-HPH-F8L-H6P-M8N-PXX-UXX-WXX

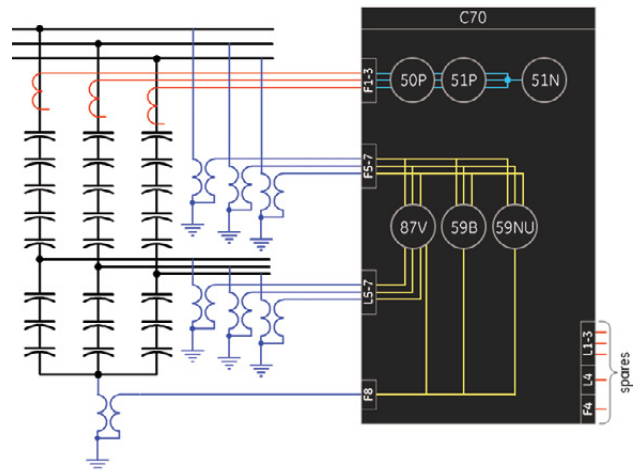

Typical Application: Ungrounded wye banks with taps

Typical Model No: C70-N03-HPH-F8L-H6P-M8L-PXX-UXX-WXX

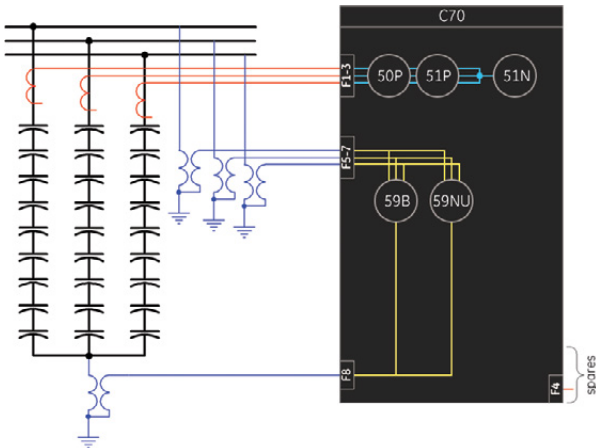

Typical Application: Ungrounded wye banks

Typical Model No: C70-N03-HPH-F8L-H6P-MXX-PXX-UXX-WXX

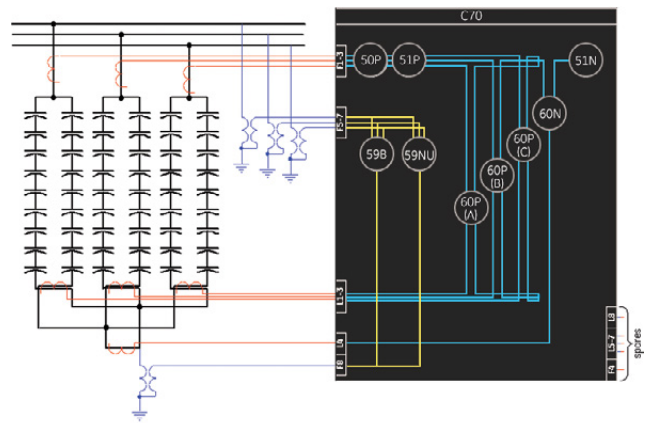

Typical Application: Ungrounded, parallel banks

Typical Model No: C70-N03-HPH-F8N-H6P-M8L-PXX-UXX-WXX

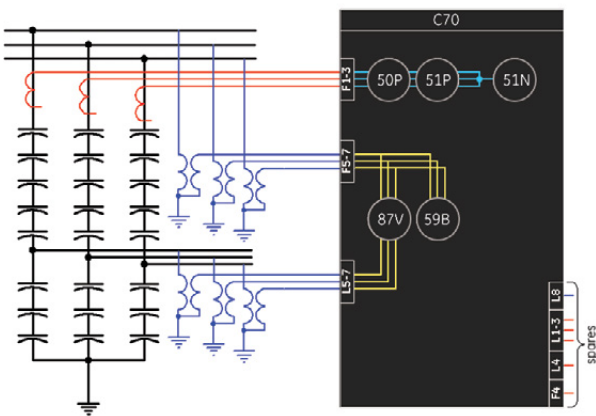

Typical Application: Grounded wye banks with taps

Typical Model No: C70-N03-HPH-F8L-H6P-M8V-PXX-UXX-WXX

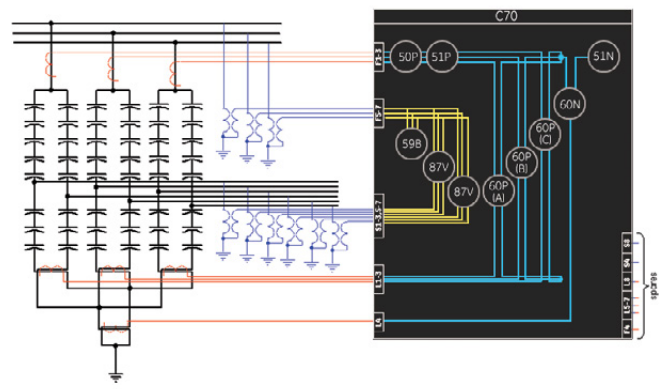

Typical Application: Grounded, parallel banks with taps

Typical Model No: C70-N03-HPH-F8N-H6P-M8L-PXX-U8V-WXX

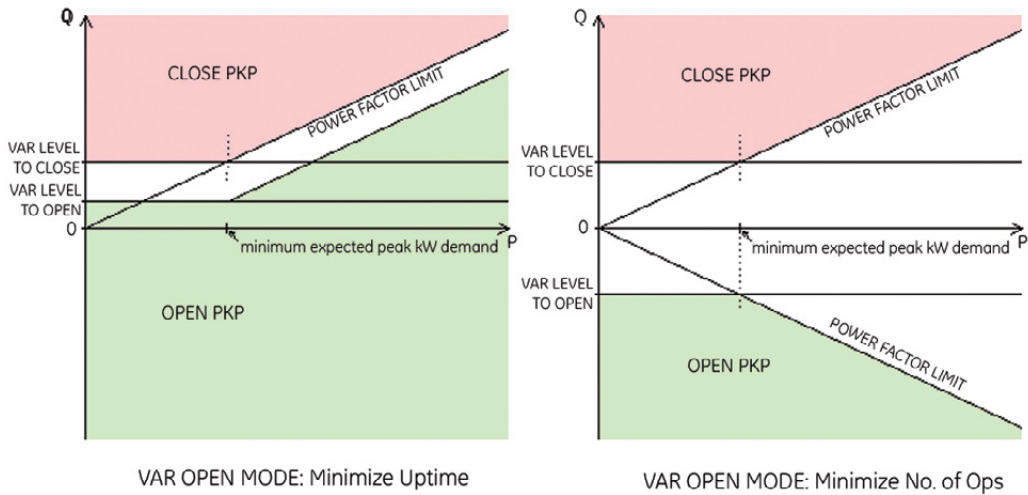

Time and Date Function

- Provides the user with ability to program certain actions based on time.
- 5 time of day timers.
- User-accessible time/date information for more sophisticated custom schemes, that respond to weekdays, weekends, summer or winter.

Advanced Automation

The C70 incorporates advanced automation features including powerful FlexLogic programmable logic, communication, and SCADA capabilities that far surpass what is found in the average capacitor bank relay. The C70 integrates seamlessly with other UR relays for complete system protection.

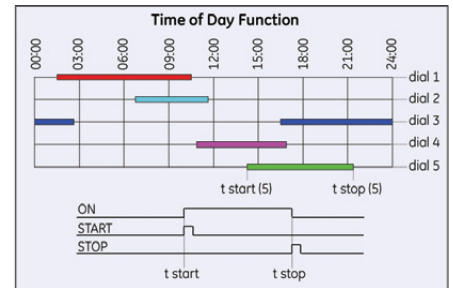

Capacitor Control Supervision

This feature supervises the capacitor bank open and close commands from the command sources, including the relay front panel HMI (push buttons), AVR and SCADA/HMI.

FlexLogic

FlexLogic is the powerful UR-platform programming logic engine that provides the ability to create customized protection and control schemes, minimizing the need and associated costs of auxiliary components and wiring.

Scalable Hardware

The C70 is available with a multitude of I/O configurations to suit the most demanding application needs. The expandable modular design allows for easy configuration and future upgrades.

With 1024 lines of FlexLogic, the C70 can be programmed to provide required tripping logic along with custom scheme logic for dynamic setting group changes.

- Multiple CT/VT configurations allow for the implementation of many different schemes
- Flexible, modular high density I/O covering a broad range of input signals and tripping schemes
- RTDs and DCmA inputs are available to monitor equipment parameters such as temperature and pressure

FlexLogic Designer

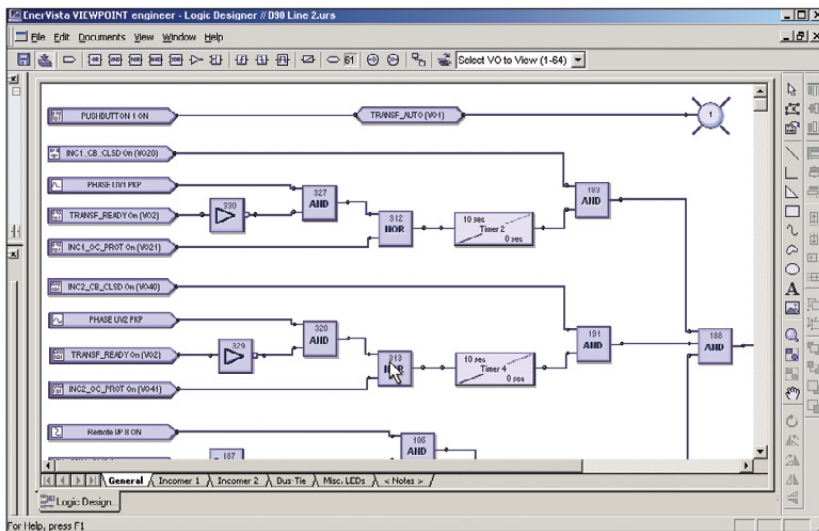

FlexLogic allows for the customization of the C70 outputs for capacitor bank protection schemes and applications.

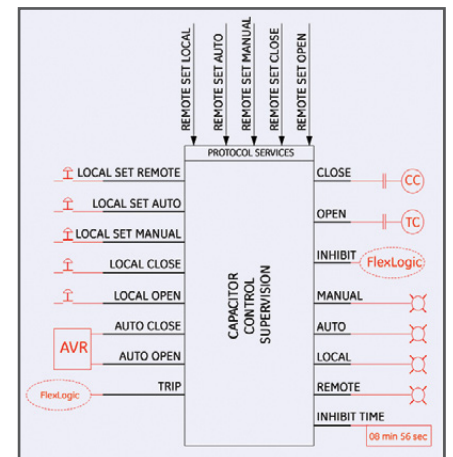

Capacitor control supervision block

IEC 61869* and 61850-9-2LE Process Bus

Three UR process bus modules enable communicating to Merging Units “MU” that comply to either IEC 61869* standard or IEC 61850-9-2LE technical report. MUs connect to the primary asset and translate analog signals and digital status/commands to standard sample values “SV” data and GOOSE messages.

Flexibility for connecting to different network size and topology is granted through 100Mbps and/ or 1Gbps Ethernet port support, plus IEC 62439 PRP or HSR standard redundancy, plus Star, Ring and Point-to-point network support.

For time synchronization purposes, this Process bus module can become an IEEE 1588 slave clock (61850-9-3 profile) or a 1588 Grand Master clock which removes the need of external time sources connected to the process bus network.

Customers who may not be using GE MU devices, could use MU from other vendors. Interoperability with MU from other vendors is expected when they comply to the mentioned standards.

IEC 61850-9-2 HardFiber Process Bus

The IEC 61850 Process Bus module is designed to interface with the GE Multilin HardFiber System, allowing bi-directional IEC 61850 fiber optic communications. The HardFiber System is designed to integrate seamlessly with existing UR applications, including protection functions, FlexLogic, metering and communications.

The GE Multilin HardFiber System offers the following benefits:

- Communicates using open standard IEC 61850 messaging
- Drastically reduces P&C design, installation and testing labor by eliminating individual copper terminations
- Integrates with existing C70’s by replacing traditional CT/VT inputs with the IEC 61850 Process Bus module
- Does not introduce new cyber security concerns

Visit the HardFiber System product page on the GE Multilin web site for more details.

Topologies:

PRP Start
Hot-Stanby

Topologies:

HSR ring
PRP start
P-2-P Process Bus

Merging units

Conventional or Optical CT/VTs

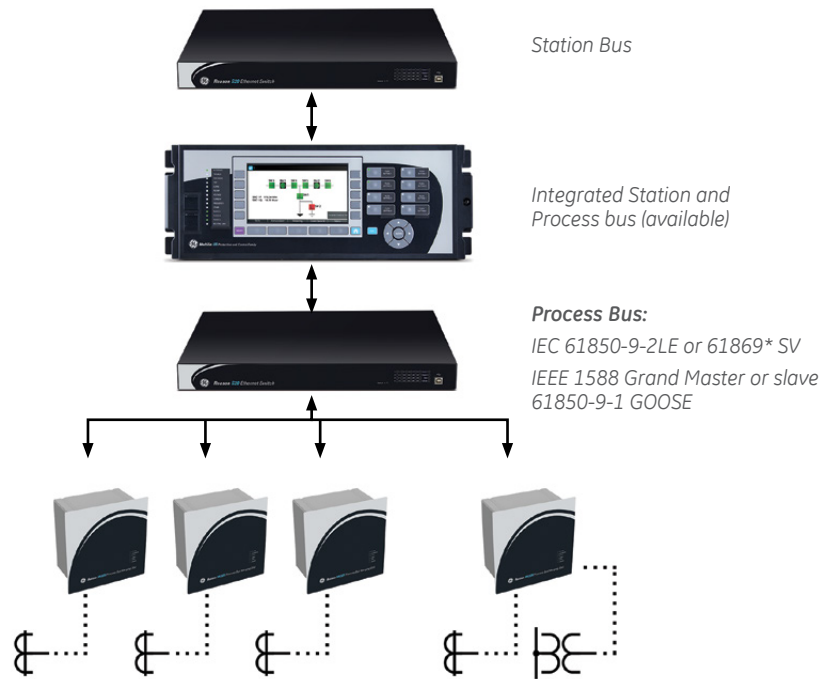

Monitoring and Metering

The C70 includes high accuracy metering and recording for all AC signals. Voltage, current, and power metering are built into the relay as a standard feature. Current and voltage parameters are available as total RMS magnitude, and as fundamental frequency magnitude and angle.

Fault and Disturbance Recording

The advanced disturbance and event recording features within the C70 can significantly reduce the time needed for postmortem analysis of power system events and the creation of regulatory reports. Recording functions include:

- Sequence of Event (SOE)
 - 1024 time stamped events
- Oscillography
 - Supports IEEE C37.111-1999/2013, IEC 60255-24 Ed 2.0 COMTRADE standard
 - 128 digital & up to 56 analog channels
 - Events with up to 45s length
- Data Logger and Disturbance Recording
 - 16 channels up to 1 sample/cycle/channel
- Fault Reports
 - Powerful summary report of pre-fault and fault values

The very high sampling rate and large amount of storage space available for data recording in the C70 can eliminate the need for installing costly stand-alone recording equipment.

Advanced Device Health Diagnostics

The C70 performs comprehensive device health diagnostic tests at startup and continuously during run-time to test its own major functions and critical hardware. These diagnostic tests monitor for conditions that could impact security and availability of protection, and present device status via SCADA communications and front panel display. Providing continuous monitoring and early detection of possible issues help improve system uptime.

- Comprehensive device health diagnostic performed at startup
- Monitors the CT/VT input circuitry to validate the integrity of all signals

Cyber Security – CyberSentry UR

CyberSentry UR enabled UR devices deliver full cyber security features that help customers to comply with NERC CIP and NIST® IR 7628 cyber security requirements. This software option delivers the following core features:

AAA Server Support (Radius/LDAP)

Enables integration with centrally managed authentication and accounting of all user activities and uses modern industry best practices and standards that meet and exceed NERC CIP requirements for authentication and password management.

Role Based Access Control (RBAC)

Efficiently administrate users and roles within UR devices. The new and advanced access functions allow users to configure up to five roles for up to eight configurable users with independent passwords. The standard "Remote Authentication Dial In User Service" (Radius) is used for authentication.

Event Recorder (Syslog for SEM)

Capture all cyber security related events within a SOE element (login, logout, invalid password attempts, remote/local access, user in session, settings change, FW update, etc), and then serve and classify data by security level using standard Syslog data format. This will enable integration with established SEM (Security Event Management) systems.

Communications

The C70 provides advanced communications technologies for remote data and engineering access, making it easy and flexible to use and integrate into new and existing infrastructures. Direct support for fiber optic Ethernet provides high-bandwidth communications allowing for low-latency controls and high-speed file transfers of relay fault and event record information. The available three independent Ethernet ports, redundant Ethernet option and the embedded managed Ethernet switch provide the means to create fault tolerant communication architectures in an easy, cost-effective manner without the need for intermediary communication hardware.

The C70 supports the most popular industry standard protocols enabling easy, direct integration into DCS and SCADA systems.

- IEC 61850 Ed. 1 and Ed. 2 Station Bus, IEC 61850-2-2LE / IEC 61869* networked or IEC 61850-9-2 HardFiber Process Bus
- DNP 3.0 (serial & TCP/IP)
- Ethernet Global Data (EGD)
- IEC 60870-5-103 and IEC 60870-5-104
- Modbus RTU, Modbus TCP/IP
- HTTP, TFTP, SFTP and MMS file transfer
- IEEE1588 and redundant SNTP for time synchronization
- PRP as per IEC 62439-3
- Supports Routable GOOSE (R-GOOSE)

Interoperability with Embedded IEC 61850 Ed. 1 and Ed. 2

The new IEC 61850 implementation in the UR Family positions GE as an industry leader in this standard.

- Implements, user selectable, Ed. 1 and Ed. 2 of the standard across the entire UR Family
- Provides full relay setting management via standard SCL files (ICD, CID and IID)
- Enables automated relay setting management using 3rd party tools through standard file transfer services (MMS and SFTP)
- Increases the number of Logical Devices and data mapped to them, GOOSE messages from up to 64 remote devices, and reports to support different organizational needs for data transfer and reduce dependency on generic logical nodes
- Configures GE Systems based on IEC 61850 using universal 3rd party tools
- R-GOOSE enable customer to send GOOSE messages beyond the substation, which enables WAPC and more cost effective communication architectures for wide area applications

Direct I/O Messaging

Direct I/O allows for the sharing of high-speed digital information between multiple UR relays via direct back-to-back connections or multiplexed through a standard DS0 multiplexer channel bank. Regardless of the connection method, direct I/O provides continuous real-time channel monitoring that supplies diagnostics information on channel health.

Direct I/O provides superior relay-to-relay communications that can be used in advanced interlocking, generation rejection and other special protection schemes.

- Communication with up to 16 UR relays in single or redundant rings rather than strictly limited to simplistic point-to-point configurations between two devices
- Connect to standard DS0 channel banks through standard RS422, G.703 or IEEE C37.94 interfaces or via direct fiber optic connections
- No external tester required to provide channel diagnostic information

LAN Redundancy

Substation LAN redundancy has been traditionally accomplished by reconfiguring the active network topology in case of failure. Regardless of the type of LAN architecture (tree, mesh, etc), reconfiguring the active LAN requires time to switchover, during which the LAN is unavailable. UR devices deliver redundancy as specified by PRP-IEC 62439-3, which eliminates the dependency on LAN reconfiguration and the associated switchover time. The UR becomes a dual attached node that transmits data packets over both main and redundant networks simultaneously, so in case of failure, one of the data packets will reach the receiving device with no time delay.

Multi-Language

UR devices support multiple languages: English, French, Russian, Chinese, Turkish, German, Polish and Japanese. These language options are available on the front panel, in the EnerVista setup software, and in the product manuals. Easily switch between English and an additional language on the local displays without uploading new firmware.

EnerVista Software

The EnerVista suite is an industry-leading set of software programs that simplifies every aspect of using the C70 relay. The EnerVista suite provides all the tools to monitor the status of the protected asset, maintain the relay, and integrate information measured by the C70 into DCS or SCADA monitoring systems. Convenient COMTRADE and SOE viewers are an integral part of the UR setup software included with every UR relay, to carry out postmortem event analysis and ensure proper protection system operation.

EnerVista Launchpad

EnerVista Launchpad is a powerful software package that provides users with all of the setup and support tools needed for configuring and maintaining GE Multilin products. The setup software within Launchpad allows for the configuration of devices in real-time by communicating using serial, Ethernet, or modem connections, or offline by creating setting files to be sent to devices at a later time.

Included in Launchpad is a document archiving and management system that ensures critical documentation is up-to-date and available when needed. Documents made available include:

- Manuals
- Application Notes
- Guideform Specifications
- Brochures
- Wiring Diagrams
- FAQ's
- Service Bulletins

Viewpoint UR Engineer

Viewpoint UR Engineer is a set of powerful tools that allows the configuration and testing of GE relays at a system level in an easy-to-use graphical drag-and-drop environment. Viewpoint UR Engineer provides the following configuration and commissioning utilities:

- Graphical Logic Designer
- Graphical System Designer
- Graphical Logic Monitor
- Graphical System Monitor

User Interface

The C70 front panel provides extensive local HMI capabilities. The local display is used for monitoring, status messaging, fault diagnosis, and device configuration. User-configurable messages that combine text with live data can be displayed when user-defined conditions are met.

A 7" color, graphic HMI is optionally available that allows users to have customizable bay diagrams with local monitoring of status, values and control functionality. The alarm annunciator panel provides the configuration of up to 96 signals (alarms and status) with full text description.

Power System Troubleshooting

The C70 contains many tools and reports that simplify and reduce the amount of time required for troubleshooting power system events.

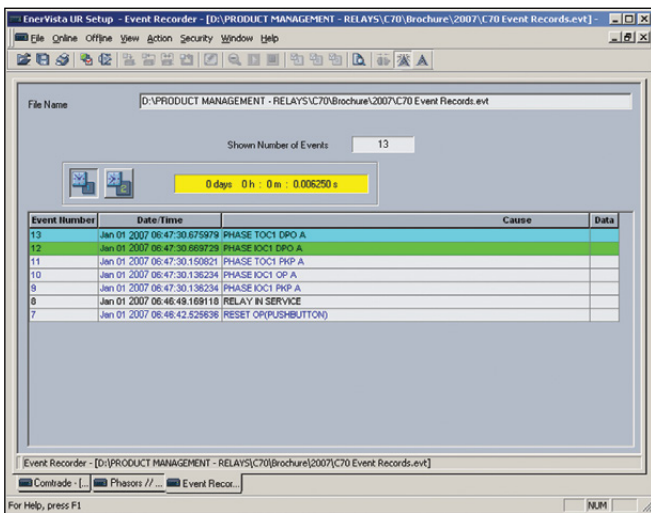

Record the operation of the internal C70 elements and external connected devices with 1ms time-stamped accuracy to identify the Sequence of Operation of station devices during capacitor bank faults and disturbances.

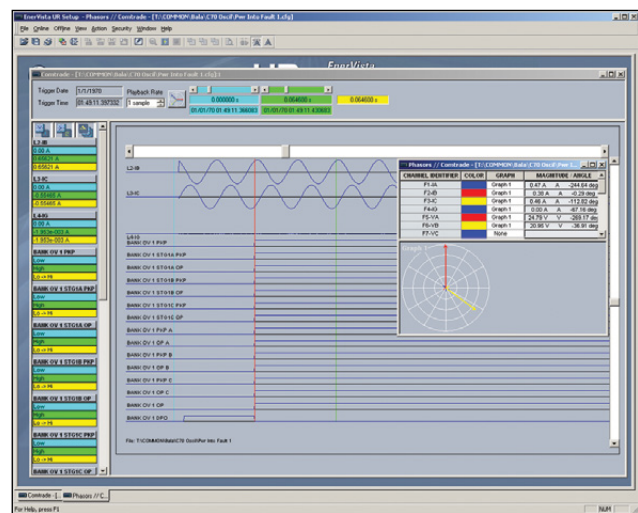

Analyze capacitor bank faults using both analog and digital power system quantities that are measured and recorded up to a rate of 64 samples per cycle.

Typical Wiring

Typical configuration.
The AC signal path is configurable.

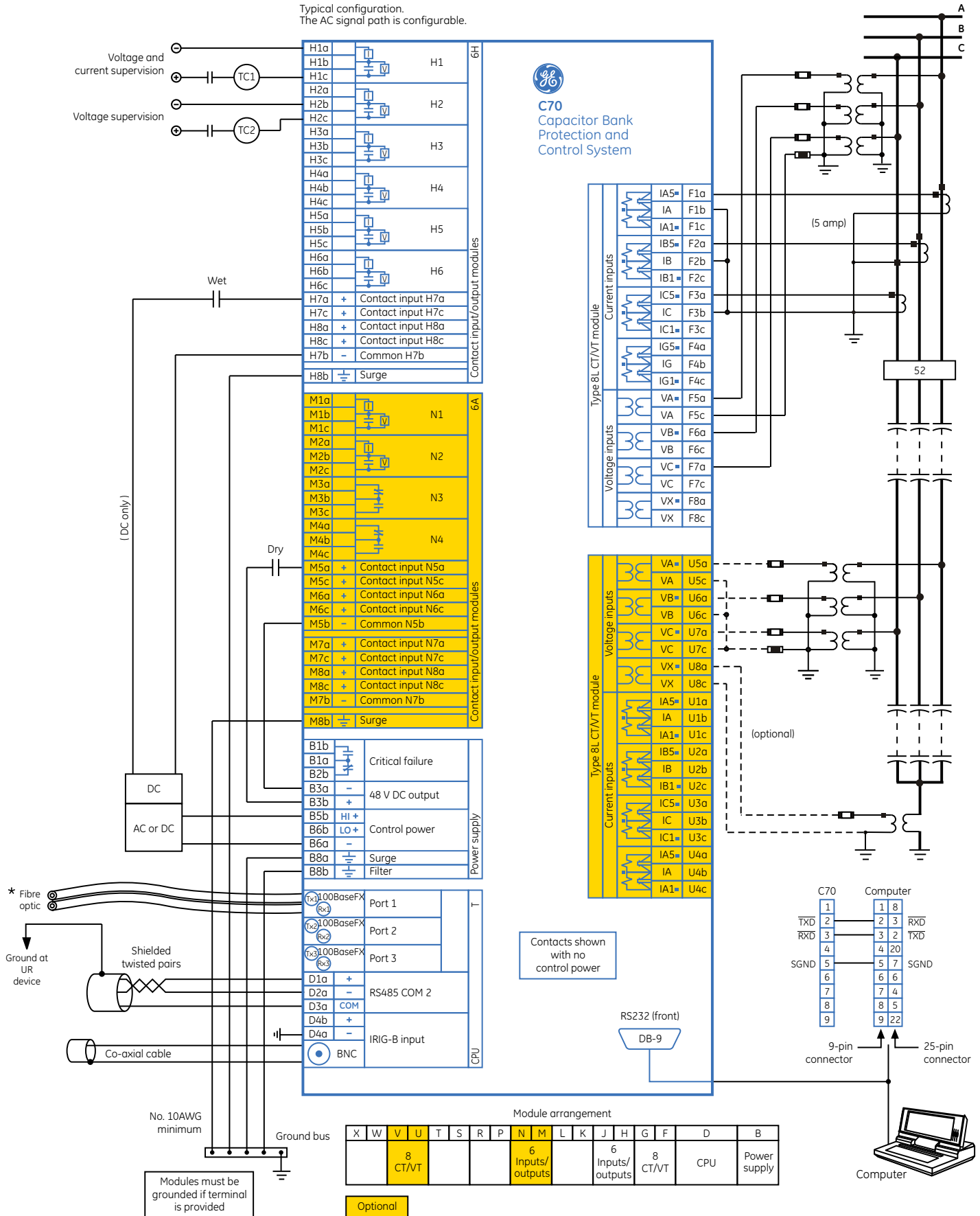

Ordering

C70 - *-00- * * *- F**- H**- M**- P**- U**- W/X**							Base Unit	
Base Unit							Base Unit	
CPU	E J N K T U V W						RS485 + RS485 (IEC 61850 option not available) RS485 + multimode ST 100BaseFX RS485 + 10/100 BaseT RS485 + multimode ST Redundant 100BaseFX RS485 + three multimode SFP LC 100BaseFX. Req FW v7xx or higher RS485 + two multimode SFP LC 100BaseFX + one SFP RJ45 100BaseT. Req FW v7xx or higher RS485 + three SFP RJ45 100BaseT. Req FW v7xx or higher RS485 + two 100BaseFx Eth, Multimode ST + one 10/100BaseT Eth, RJ-45 ²	
Software Options ¹	00 03 12 13 A0 B0 C0 D0						None IEC 61850 Enhanced Capacitor Bank Control (AVR, Capacitor Control Supervision, Time & Date) Enhanced Capacitor Bank Control (AVR, Capacitor Control Supervision, Time & Date) + IEC 61850 CyberSentry UR Lvl 1. Req UR FW 7.xx or higher IEEE 1588. Req UR FW 7.xx or higher PRP IEEE 1588 + CyberSentry. Req UR FW 7.xx or higher	
Mounting / Conformal Coating		H A					Horizontal (19" rack) - Standard Harsh Chemical Environment Option	
User Interface						E F I J K L M N O Q T U V W Y H O X Z	7" Graphical display, USB front port & programmable pushbuttons - Multi-Language (FW 7.6x or higher) Vertical Front Panel with English Display Enhanced German Front Panel Enhanced German Front Panel with User-Programmable Pushbuttons Enhanced English Front Panel Enhanced English Front Panel with User-Programmable Pushbuttons Enhanced French Front Panel Enhanced French Front Panel with User-Programmable Pushbuttons Enhanced Russian Front Panel Enhanced Russian Front Panel with User-Programmable Pushbuttons Enhanced Chinese Front Panel Enhanced Chinese Front Panel with User-Programmable Pushbuttons Enhanced Turkish Front Panel Enhanced Turkish Front Panel with User-Programmable Pushbuttons Enhanced Polish Front Panel ² Enhanced Polish Front Panel with User-Programmable Pushbuttons ² Enhanced Japanese Front Panel ² Enhanced Japanese Front Panel with User-Programmable Pushbuttons ²	
Power Supply			H L				125/250 V AC/DC 24 - 48 V (DC only)	
CT/VT DSP				8L 8N 8V		8L 8N 8V	Standard 4CT/4VT w/ enhanced diagnostics Standard 8CT w/ enhanced diagnostics Standard 8VT w/ enhanced diagnostics	
IEC 61850 Process Bus ^{3,4}							8 Port IEC 61850 Process Bus Module -9-2LE & 61869* Process Bus, 2 x 1000BaseF -9-2LE & 61869* Process Bus, 4 x 1000BaseF + 4 x 100BaseFx -9-2LE & 61869* Process Bus, 4 x 100BaseFx	
Digital I/O							No Module 2 Form-A (Voltage w/ opt Current) & 2 Form-C Outputs, 8 Digital Inputs 2 Form-A (Voltage w/ opt Current) & 4 Form-C Outputs, 4 Digital Inputs 8 Form-C Outputs 16 Digital Inputs 4 Form-C Outputs, 8 Digital Inputs 8 Fast Form-C Outputs 4 Form-A (Voltage w/ opt Current) Outputs, 8 Digital Inputs 6 Form-A (Voltage w/ opt Current) Outputs, 4 Digital Inputs 4 Form-C & 4 Fast Form-C Outputs 2 Form-A (Current w/ opt Voltage) & 2 Form-C Outputs, 8 Digital Inputs 2 Form-A (Current w/ opt Voltage) & 4 Form-C Outputs, 4 Digital Inputs 4 Form-A (Current w/ opt Voltage) Outputs, 8 Digital Inputs 6 Form-A (Current w/ opt Voltage) Outputs, 4 Digital Inputs 2 Form-A (No Monitoring) & 2 Form-C Outputs, 8 Digital Inputs 2 Form-A (No Monitoring) & 4 Form-C Outputs, 4 Digital Inputs 4 Form-A (No Monitoring) Outputs, 8 Digital Inputs 6 Form-A (No Monitoring) Outputs, 4 Digital Inputs 2 Form-A (Cur w/ opt Volt) 1 Form-C Output, 2 Latching Outputs, 8 Digital Inputs 30 Contact Inputs - Pin Terminals ² 18 Form-A (No Monitoring) Outputs - Pin Terminals ² High Power Supply 6-port managed Ethernet switch Low Power Supply 6-port managed Ethernet switch 4 dcmA Inputs, 4 dcmA Outputs 820 nm, multimode, LED, 2 Channels	
Transducer I/O				5A	5A	5A	5A	2S 2T
Inter-Relay Communications								21 Channel 1 - IEEE C37.94, 820nm, multimode fiber, 64/128 kbps; Channel 2 - 1300 nm, singlemode, LASER 2J Channel 1 - IEEE C37.94, 820nm, multimode fiber, 64/128 kbps; Channel 2 - 1550 nm, singlemode, LASER 7H 1300 nm, multimode, LED, 2 Channels 7I G.703, 2 Channels 7S RS422, 2 Channels 7W IEEE C37.94, 820 nm, multimode, LED, 2 Channel 77 6 port, 100 Mbps, Managed Ethernet Switch, HI (125/250V AC/DC)

Ordering Notes:

- To view all the options available for C70, please visit GE's On-Line Store at <http://store.gedigitalenergy.com/viewprod.asp?model=C70>
- Option available soon
- Process bus module requires empty slots next to it.
- Conventional DSP and Process Bus modules cannot run simultaneously

Footnote: * Upcoming release



imagination at work

GEGridSolutions.com

IEC is a registered trademark of Commission Electrotechnique Internationale. IEEE is a registered trademark of the Institute of Electrical Electronics Engineers, Inc. Modbus is a registered trademark of Schneider Automation. NERC is a registered trademark of North American Electric Reliability Council. NIST is a registered trademark of the National Institute of Standards and Technology.

GE, the GE monogram, Multilin, FlexLogic, EnerVista and CyberSentry are trademarks of General Electric Company.

GE reserves the right to make changes to specifications of products described at any time without notice and without obligation to notify any person of such changes.

Copyright 2020, General Electric Company. All Rights Reserved.

GEA-12755LEI
English
200218