



# OSKF

## Oil-Insulated Current Transformers 72.5 kV to 800 kV

### Designed to Meet the Highest Expectations

For years, network managers have trusted our OSKF current transformers and thousands are installed in substations around the world. Our customers recognize our top-of-the-line CTs for their long-term strength, safety and reliability for system voltages up to 800 kV.

### Long Service Life and near Zero Maintenance

OSKF current transformers have been designed for a 30 year lifetime and, due to the soundness of the technical concepts many well out-live this service life. They have near-zero maintenance requirements, as the oil is hermetically sealed from the air by a stainless steel diaphragm assembly and all external parts are of corrosion-resistant material.

### Characteristics

- High quality paper-oil insulation
- Top core design with metal head
- Oil expansion by stainless steel diaphragm bellows
- Oil level indicator
- Secondary cores in aluminum box
- Changing of primary ratio primary series-parallel connection (double or triple ratio) or by secondary taps.

### Performance

- Un: 72.5 to 800 kV
- In: up to 5,000 A
- In short-circuit: up to 120 kA (Isc dyn: 324 kA peak)
- Secondary cores: up to 8

### Seismic Withstand

Standard design up to 0.5 g (higher values on request).

Compliance with IEC, ANSI/IEEE or equivalent standards.  
Other standards on request.



### Key Benefits

- Extensive field experience, including highly seismic regions
- Special accuracy classes for protection: PR, PX, PXR, TPX, TPY, TPZ
- Mineral oil-filled: no PCB
- Operational security
- Stable accuracy over a long period of time
- Built for long life with near zero maintenance



### Top Core Design and Primary Windings

The 'inverted CT' design, with active parts in the head, offers particular advantages for higher currents. The primary is normally a straight bar type conductor.

Ratio change can be accomplished either by primary series-parallel connection (double or triple ratio) or by secondary taps. Combinations of series-parallel connection and secondary taps are also possible. This maintains the output and accuracy of the secondaries at all ratios.

The top core design also has the advantage of spreading the primary winding in a uniform and symmetrical way around the cores, avoiding local saturation and reducing the leakage

### Construction Overview

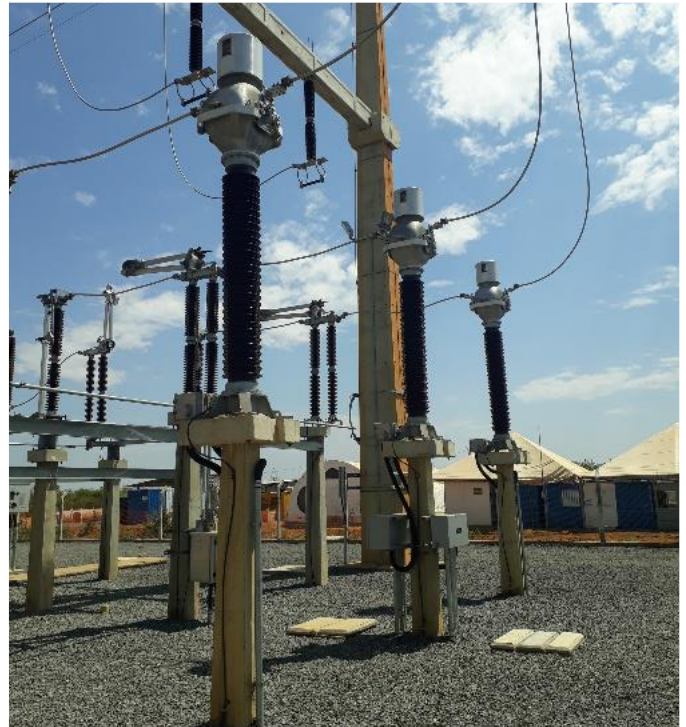
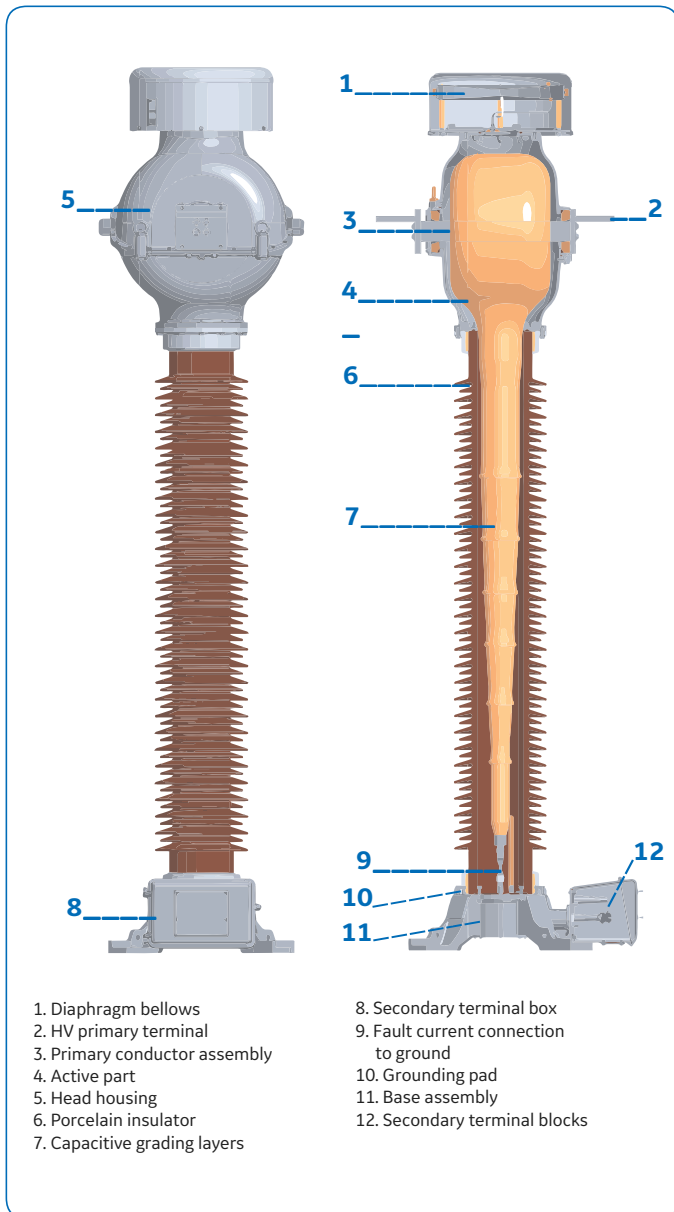

### Cores and Secondary Windings

Current transformers can have several toroidal laminated cores which are independent of each other. The cores with the secondary winding are accommodated in a thick-walled, round core aluminium protection.

The core housing is connected to a strong metal pipe inside the insulator which leads to the base plate. Cross sections and connections have been dimensioned in such way that the current can be led to the ground in case of internal failure, avoiding an arc inside the insulator.

### High Quality Paper-Oil Insulation

Insulating paper is applied to the core housing and its supporting tube by a special wrapping machine to ensure high density and uniform insulation.

An extremely low residual humidity is obtained by a special paper insulation drying process. Grading layers with well-rounded edges give a uniformly distributed field over the entire unit. Only the highest quality mineral oil with excellent durability and gas-absorbing properties is used. The insulating oil contains no PCB.

Controlled vacuum and temperature treatments withdraw humidity and gas from the paper insulation and insulating oil; the impregnation process results in a high-grade dielectric system.

## Hermetically Sealed

The OSKF maintains a completely sealed and pressure free system through the use of a stainless steel metallic diaphragm assembly. The diaphragm assembly provides oil expansion and pressure compensation, protects the interior from air and moisture and preserves the dielectric strength of the unit. The movements of the diaphragm assembly are translated to an indirect oil level indicator which is visible behind a window in the diaphragm cover.

## Leakproof Design

The head housing is made of corrosion-proof aluminum alloy. Every housing is subjected to a vacuum leak test by helium leak detection. An overall leak test is performed on every completely assembled unit before oil filling.

## Primary Terminals

The standard primary terminals consist of aluminium flat terminal pads with 4, 6, 8, or more holes. On request, single or double round terminals made of nickel-plated-copper can be provided.

## Secondary Terminal Box

The terminal box is very spacious and has a removable plate located at the bottom which allows for in-factory or on-site drilling of the conduit entrances for the insertion of cable glands as desired.

## Insulator

The outer insulation consists of high-quality oxide porcelain in brown (RAL 8016) or grey (ANSI 70). Standard creepage distances are available according to the dimension tables. Larger creepage distances and composite insulators are available on request.

## Protection against Bursting

The optimised insulation structure and appropriate structural measures secure the high-grade dielectric for a very long time. The following additional measures are taken to prevent the porcelain from bursting in the event of an inner insulation breakdown, e.g., in case of lightning strikes:

- The active part is above the porcelain in an aluminium head housing.
- An internal fault current connection is provided between the core housing and the ground terminal on the base.
- A pressure relief plate exists in the area of the expansion body on the head.
- Upon request, a composite insulator consisting of fiberglass reinforced pipe and silicone rubber screens can be provided instead of the porcelain porcelain insulator.

## Earthquake-Proof Design

The standard OSKF resists medium intensity seismic events. More stringent seismic design requirements can be met upon special request.

## Testing

Testing is in conformance with national and international standards. Along with the power-frequency test, capacitance, dielectric loss factor and inner partial discharges are also measured as routine tests. Tests certificates are issued and supplied with the equipment.

## Additional Information

### Dielectric Loss factor:

Tan $\delta$  smaller than 0.005 up to the power-frequency withstand test voltage

### Radio Influence Voltage (RIV):

According to IEC 61689-1  
Other values on request.

### Internal Partial Discharge:

Less than 10 pC at 1.2 U<sub>m</sub>

### Frequency:

50 Hz or 60 Hz or 16 2/3 Hz.  
Other value on request.

### Ambient Temperature:

-35 °C...+40 °C on a 24 h average. Other designs can be provided upon request for temperatures ranges falling outside of the mentioned range, i.e. -50 °C to +50 °C

### Mechanical Strength:

According to IEC 61689-1 & -2.  
Other values on request.



## Dimensions and Weights

Type		OSKF 72	OSFK 123	OSKF 145	OSKF 170	OSKF 245	OSFK 362	OSKF 420	OSKF 550	OSKF 800
Maximum system voltage ( $U_m$ )	kV	72.5	123	145	170	245	362	420	550	800
Impulse test voltage (BIL)	kV	350	550	650	750	1050	1300	1425	1550	2100
Standard creepage distance (*)	mm	1813	3150	3750	4583	6300	10418	11560	14443	20000
Dimensions mm	A	1953	2333	2745	2880	3606	4402	4642	5397	8250
	B	1462	1842	2007	1720	2859	3632	3872	4578	6980
	C	305	305	305	305	305	388	388	388	420
	D	798	798	849	849	935	1021	1021	1021	1075
	E	450	450	450	600	600	600	600	600	900
Total weight (approx.)	kg	310	351	415	529	755	1150	1215	1560	3500
Weight of oil (approx.)	kg	39	62	97	110	150	277	293	320	930

Indicatives value only - All indicated dimensions must be confirmed with order.

(\*) - Standard creepage distance (mm) - Other value on request.

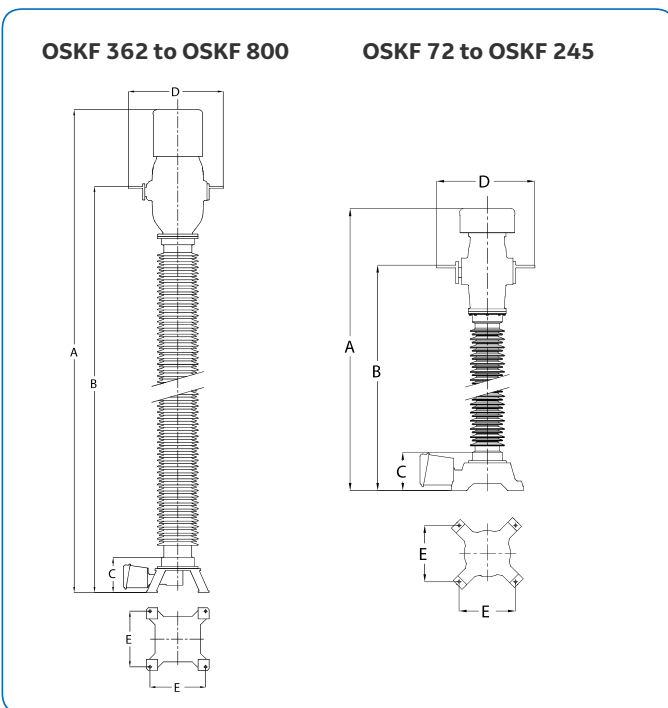

The above mentioned dimensions refer to standard versions. Other  $U_m$  values affect other dimensions.

The head size can change, depending on the core data and the primary nominal current. With regard to the creepage distance and clearance, the insulator can be adapted to the customers' request.

For more information please contact  
GE  
Grid Solutions

### Worldwide Contact Center

Web: [www.GEGridSolutions.com/contact](http://www.GEGridSolutions.com/contact)  
Phone: +44 (0) 1785 250 070

## Inquiry Check List

- Applicable standards
- Rated frequency
- Highest system voltage
- Test voltages (power frequency, lightning impulse)
- Primary/secondary rated currents
- Short time current and duration
- Core rating (burden, accuracy)
- Environmental conditions (altitude, temperatures, pollution, seismic conditions...)
- Options:
  - Composite insulator
  - Surge arrester on secondary winding
  - Ground cable connector
  - Primary terminal
  - Specific design for use in highly active seismic regions

### Available accessories:

- Tan $\delta$  tap
- Oil sampling valve
- Lifting bar
- Oil sampling kit
- Shock indicators during shipment

## GEGridSolutions.com

IEC is a registered trademark of Commission Electrotechnique Internationale. IEEE is a registered trademark of the Institute of Electrical Electronics Engineers.

GE and the GE monogram are trademarks of General Electric Company.

GE reserves the right to make changes to specifications of products described at any time without notice and without obligation to notify any person of such changes.

OSKF-IEC-Brochure-EN-2020-10-Grid-AIS-0042. © Copyright 2020, General Electric Company. All rights reserved.



Imagination at work