



OSKF

Oil-Insulated Current Transformers 72.5 kV to 800 kV

Designed to Meet the Highest Expectations

For years, network managers have trusted our OSKF current transformers and thousands are installed in substations around the world. Customers recognize our top-of-the-line CTs for their long-term strength, safety and reliability for system voltages up to 800 kV. The enduring success of this series is the result of a well executed design entirely focused on addressing the goals of safety and long life.

Long Service Life and near Zero Maintenance

OSKF current transformers have been designed for a 30 year lifetime and, due to the soundness of the technical concepts many well out-live this service life. They have near-zero maintenance requirements, as the oil is hermetically sealed from the air by a stainless steel diaphragm assembly and all external parts are of corrosion-resistant material.

Characteristics

- High quality paper-oil insulation
- Head type design with aluminum housing
- Oil expansion and hermetic seal by stainless steel diaphragm bellows
- Oil level indicator
- Secondary cores isolated in heavy walled grounded housing
- Changing of primary ratio by secondary taps or primary connection

Performance

- U_n : 72.5 to 800 kV
- I_n : up to 5,000 A
- I_n : short-circuit: up to 120 kA" (Isc dyn: 324 kA peak)
- Secondary cores: up to 8

Seismic Withstand

Standard design up to 0.5 g.

Compliance with ANSI/IEEE, IEC or equivalent standards.

Other standards on request.



Key Benefits

- Conservative and safe design
- Extensive field and extreme climate experience
- Burst (internal arc) protected
- Maintenance-free
- Stable accuracy over its lifetime
- Rugged, leak-proof design



Head Type Design and Primary Windings

The 'inverted CT' design, with active part in the head, offers particular advantage for higher currents. The primary is normally a straight bar type conductor with low inductance. Therefore no primary surge protection is required.

Ratio change can be accomplished either by primary series-parallel connection (single, double or quadruple ratio) or by secondary taps.

The head type design also has the advantage of spreading the primary flux in a uniform and symmetrical way through the cores, avoiding local saturation and reducing the leakage flux.

Construction Overview

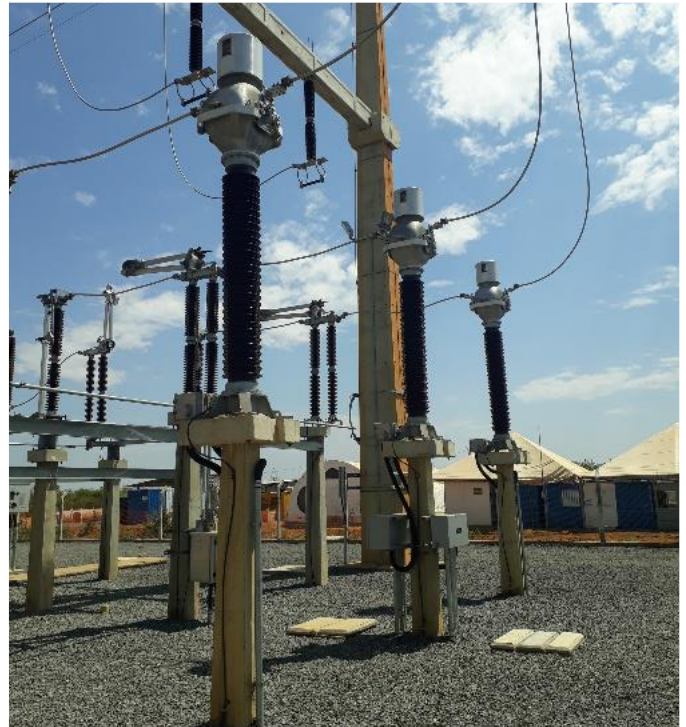
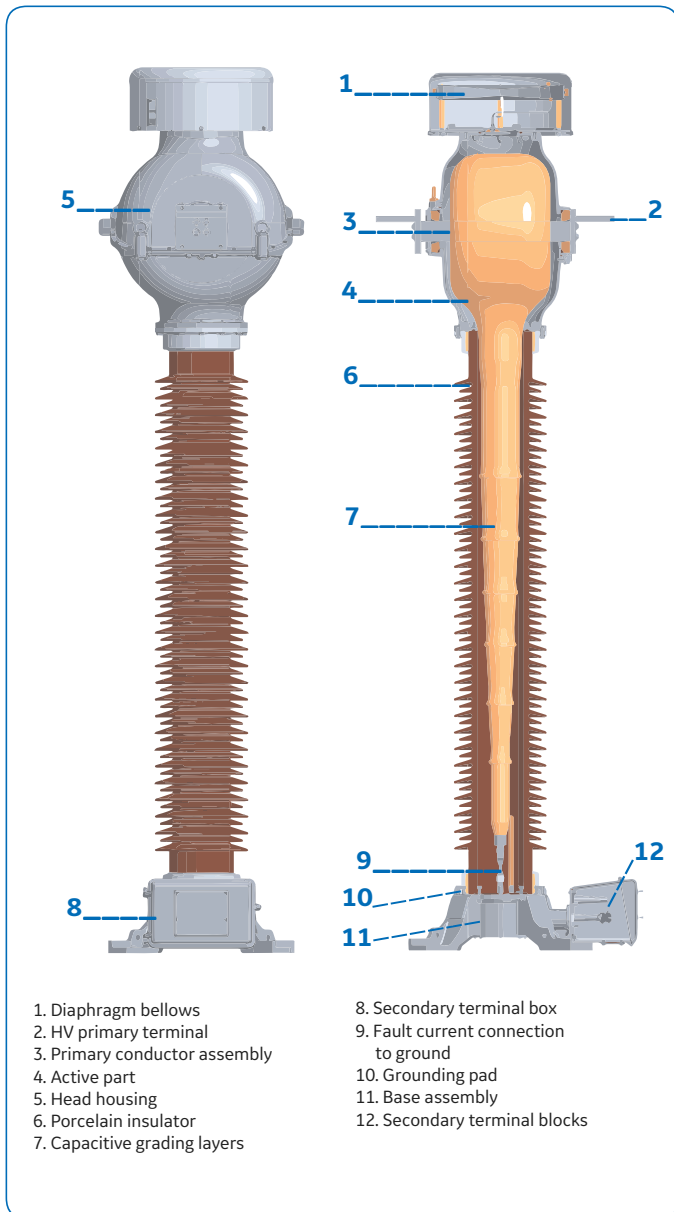

Cores and Secondary Windings

CTs can have several toroidal laminated cores which are independent of each other. Cores with secondary winding are accommodated in a thick-walled, round aluminum core housing for protection.

The core housing is mounted on a heavy gauge metal tube inside the insulator which leads to the base plate. Cross sections and connections have been dimensioned to provide a fault current path to ground greatly reducing the opportunity for a secondary arc within the insulator.

As a result of this design an open secondary winding flashover limited in time will not damage the high voltage insulation; and a high voltage insulation breakdown does not impair the function of the secondaries.

High Quality Paper-Oil Insulation

Insulating paper is applied to the core housing and its supporting tube by a special wrapping machine to ensure high density and uniform insulation. Low impedance grading layers with well-rounded edges ensure a uniformly distributed field over the entire unit, therefore surge arrestors are not required to protect the CT. Only a name brand mineral oil with excellent durability and gas-absorbing properties is used.

The insulating oil contains no PCB.

Controlled vacuum and temperature treatments withdraw humidity and gas from the paper insulation and insulating oil; the impregnation process results in a high-grade dielectric system.

Hermetically Sealed

The OSKF maintains a completely sealed and pressure free system through the use of a stainless steel metallic diaphragm assembly. The diaphragm assembly provides oil expansion and pressure compensation, protects the interior from air and moisture, and preserves the dielectric strength of the unit. The movements of the diaphragm assembly are translated to an indirect oil level indicator which is visible behind a window in the diaphragm cover. Effectively oil maintenance, change or inspection is eliminated and the CT operates pressure free.

Leakproof Design

The head housing is made of corrosion-proof aluminum alloy. Every housing is subjected to a vacuum leak test by helium leak detection. An overall leak test is performed on every assembled unit before oil filling. All seals are formed by single piece O-Rings in fully machined grooves.

Primary Terminals

The standard primary terminals consist of aluminium flat terminal pads with 4, 6, 8, or more holes. On request, single or double round terminals made of nickel-plated-copper can be provided.

Secondary Terminal Box

The terminal box can be provided with conduit entrances for the insertion of cable glands by the factory or performed on-site by the customer. The secondaries are brought out through an oil/air seal block assembly and terminated on separate terminal blocks with 8-32 screws. Other terminals on request.



Insulator

The outer insulation consists of aluminum oxide porcelain in grey (ANSI 70) or brown (RAL 8016). Standard creepage distances are available according to the dimension tables. Higher creepage distances and composite insulators are available on request.

Protection against Bursting

The optimized insulation structure and mechanical design ensure dielectric integrity for a very long time. The following additional measures are taken to prevent the insulator from failing in the event of an inner insulation breakdown. The capacitive grading in the high voltage insulation is designed to withstand transient overvoltages to be expected during service life:

- The active part is above the porcelain in an aluminum head housing.
- An internal fault current connection is provided between the core housing and the ground terminal on the base.
- A pressure relief plate exists in the area of the expansion body on the head.
- Upon request, a composite insulator consisting of fiberglass reinforced pipe and silicone rubber screens can be provided instead of the porcelain porcelain insulator.

Testing

Testing is in conformance with national and international standards. Along with the power-frequency test, capacitance, dielectric loss factor and inner partial discharges are also measured as routine tests. Tests certificates are issued and supplied with the equipment.

Additional Information

Dielectric Loss factor:

Tan δ smaller than 0.005 up to the power-frequency withstand test voltage

Radio Influence Voltage (RIV):

Per IEEE C57.13.5

Internal Partial Discharge:

Less than 10 pC at 1.2 U_m

Frequency:

50 Hz or 60 Hz or 16 2/3 Hz.
Other value on request.

Ambient Temperature:

-35 °C.....+40 °C on a 24 h average. Other designs can be provided upon request for temperature ranges falling outside of the mentioned range, i.e. -50 °C to +50 °C

Mechanical Strength:

According to IEC 61689-1 & IEEE C57.13.5.
Other values on request.



Dimensions and Weights

The following dimensions refer to standard versions. Other U_m values affect other dimensions. The head size can change, depending on the core data and the primary nominal current. With regard to the creepage distance and clearance, the insulator can be adapted to the customers' request.

Type		OSKF72		OSKF123		OSKF145		OSKF170		OSKF245	
Highest voltage for equipment (U_m)	kV	72.5		123		145		170		245	
Lightning impulse withstand voltage (BIL)	kV	350		550		650		750		1050	
		mm	in	mm	in	mm	in	mm	in	mm	in
Minimum creepage distance		1813	71.4	3150	124.0	3750	147.6	4583	180.4	6300	248.0
Dimensions	A	1844	72.6	2224	87.6	2582	101.7	2837	111.7	3442	135.5
	B	1414	55.7	1795	70.7	2029	79.9	1720	89.9	2305	113.4
	C	305	12.0	305	12.0	305	12.0	305	12.0	305	12.0
	D	798	31.4	798	31.4	849	33.4	849	33.4	935	36.8
	E	450	17.7	450	17.7	450	17.7	450	17.7	600	23.6
		kg	lb	kg	lb	kg	lb	kg	lb	kg	lb
Total weight (approx.)		270	595	340	750	446	983	489	1078	609	1342
Oil volume (approx.)	gal.	11.6		15.5		26.2		31.8		37.8	

Type (Continued)		OSKF362		OSKF550		OSKF800	
Highest voltage for equipment (U_m)	kV	362		550		800	
Lightning impulse withstand voltage (BIL)	kV	1300		1800		2100	
		mm	in	mm	in	mm	in
Minimum creepage distance		10418	410.2	15225	599.4	20000	147.6
Dimensions	A	4517	177.9	5737	225.9	8250	101.7
	B	3027	143.8	4148	189.7	6980	79.9
	C	377	14.9	418	16.4	420	12.0
	D	1021	40.2	1043	41.1	1075	33.4
	E	600	23.6	600	23.6	900	17.7
		kg	lb	kg	lb	kg	lb
Total weight (approx.)		1150	2535	1780	3924	3500	983
Oil volume (approx.)	gal.	83.1		137.0		218.9	

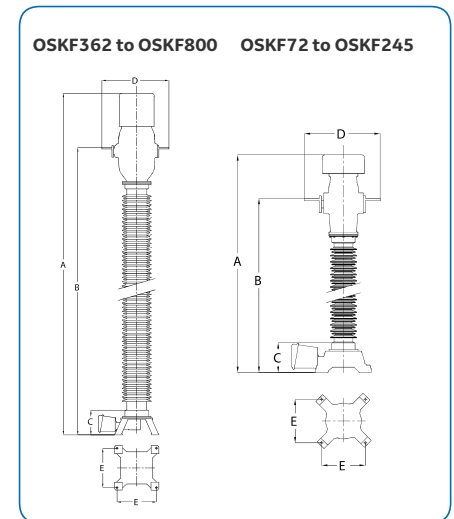

Inquiry Check List

- Applicable standards
- Rated frequency
- Highest system voltage
- Test voltages (power frequency, lightning impulse)
- Primary/secondary rated currents
- Short time current and duration
- Core rating (burden, accuracy)
- Environmental conditions (altitude, temperatures, pollution, seismic conditions...)

- Options:
 - Composite insulator
 - Spark Gap on secondary winding
 - Ground fault current transformer
 - Capacitive tap
 - Specific design for use in highly active seismic regions

Available accessories:

- Ground cable connector
- Primary terminal connectors
- Oil sampling kit

For more information please contact
GE
Grid Solutions

Worldwide Contact Center

Web: www.GEGridSolutions.com/contact
Phone: +44 (0) 1785 250 070

GEGridSolutions.com

IEC is a registered trademark of Commission Electrotechnique Internationale. IEEE is a registered trademark of the Institute of Electrical Electronics Engineers.

GE and the GE monogram are trademarks of General Electric Company.

GE reserves the right to make changes to specifications of products described at any time without notice and without obligation to notify any person of such changes.

OSKF-ANSI-Brochure-EN-2020-10-Grid-AIS-0048. © Copyright 2020, General Electric Company. All rights reserved.



Imagination at work