

## Globally Approved for Accuracy and Safety



### Process Weighing

Due to the hermetically sealed design, MTB is ideal for harsh environments in process or food applications. The full set of approvals makes it the right choice for your application.



### Tank Weighing

The capacity range from 5kg to 500kg makes the weighing of small vessels possible. The stainless steel design, hermetic sealing and IP68/IP69K protection provides the best reliability in these applications.



### SWB505 MultiMount™ Weigh Module

With the optional SWB505 MultiMount™ weigh module METTLER TOLEDO provides a complete solution for vessel weighing in harsh environments. MultiMount™ is available in zinc plated and stainless steel version.

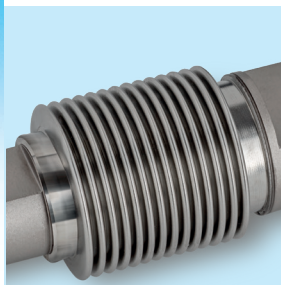

### Hermetically Sealed

MTB load cells are made from stainless steel and hermetically sealed by laser welding. This protects the load cell from damp for the best stability and measuring performance.



### MTB Load Cell Fully Approved

The MTB is approved for use in various applications in Europe, Asia, America and almost everywhere else in the world. If an approval is required, the MTB probably already complies. If ever needed for hazardous areas later, the MTB is already prepared.

The MTB load cell features:

- OIML C3, C6, NTEP IIIM 5,000d and IIIS 3,000d approvals
- ATEX Zone1/2 and 21/22 approvals
- FM Class I,II,III Div 1&2 approvals for USA & Canada
- Stainless steel
- Hermetically sealed design
- IP68/IP69K protection class
- All approvals standard on every Load Cell

# MTB Load Cell Specifications

Parameter		unit of measure	Specification								
Model No.			MTB								
Rated Capacity (R.C.)		kg (lb, nominal)	5 (11)	10 (22)	20 (44)	30 (66)	50 (110)	100 (220)	200 (441)	300 (661)	500 (1102)
Rated Output		mV/V @R.C.	2 ± 0.1%								
Zero load Output		%R.C.	≤ 1								
Combined Error <sup>(1)(2)</sup>		%R.C.	C3: ≤ 0.018 / C6: ≤ 0.012								
Repeatability Error		%A.L. <sup>(3)</sup>	C3: ≤ 0.01 / C6: ≤ 0.005								
Creep, 30 minute		%A.L.	≤ 0.05 <sup>(5)</sup>	C3: ≤ 0.017 / C6: ≤ 0.008							
Min. Dead Load Output Return (DR), 30 min		%A.L.	-	C3: ≤ 0.017 / C6: ≤ 0.008							
Temperature Effect on Min. Dead load Output		%R.C./°C (./°F)	C3: ≤ 0.001 (0.0006) / C6: ≤ 0.001 (0.0006)								
Sensitivity <sup>(2)</sup>		%A.L./°C (./°F)	C3: ≤ 0.001 (0.0006) / C6: ≤ 0.0005 (0.0003)								
Temperature Range Compensated		°C (°F)	-10 ~ +40 (+14 ~ +104)								
Operating			-40 ~ +65 (-40 ~ +150)								
Safe Storage			-40 ~ +80 (-40 ~ +176)								
OIML / European Approval <sup>(4)</sup>	Number, OIML / Europe		-	R60/2000-NL 1-05.18 / NMI TC6035							
	Class		-	C3	C6	C3 / C6			C3		
	nmax		-	3000	6000	3000 / 6000			3000		
	Y		-	12000							
	PLC		-	0.7							
	Humidity Symbol		-	none							
	Min. dead load	kg (lb)	-	0 (0)							
	Z		-	3000	6000	3000/ 6000			3000		
Barometric Pressure Effect	Vmin/kPa	-	none								
NTEP Approval <sup>(4)</sup>	Number		06-045								
	Class		III S / III M								
	nmax		3000 / 5000								
	Vmin	kg (lb)	R.C./12000								
	Min. dead load	kg (lb)	0 (0)								
ATEX Approval <sup>(4)</sup>	Number		KEMA 05ATEX1178 X / KEMA 05ATEX1179								
	Rating		II 2 G Ex ib IIC T4 / II 2 D ibD 21 IP6X T135°C II 3 G Ex nA II T4 / II 3 G Ex nL IIC T4 / II 3 D Ex tD A22 IP6X T 135°C								
	Entity Parameters		Ui = 25V, li = 600mA, Pi = 1.25W, Ci = 0.2 nF/m (6), Li = 1µH/m (6)								
IECEx Approval <sup>(4)</sup>	Number		IECEx DEK 16.0031X								
	Rating		II 2 G Ex ib IIC T4 / II 2 D ibD 21 IP6X T135°C II 3 G Ex nA II T4 / II 3 G Ex nL IIC T4 / II 3 D Ex tD A22 IP6X T 135°C								
	Entity Parameters		Ui = 25V, li = 600mA, Pi = 1.25W, Ci = 0.2 nF/m (6), Li = 1µH/m (6)								
Factory Mutual Approval <sup>(4)</sup>	Number, USA / Canada		FM18US0025 / FM18CA0032								
	Rating, USA		IS / I, II, III / 1 / ABCDEFG / T4 Entity NI / 1 / 2 / ABCD / T6 NIFW; S / II, III / 2 / FG / T6								
	Rating, Canada		IS / I, II, III / 1 / ABCDEFG / T4 Entity NI / 1 / 2 / ABCD / T6 NIFW; DIP / II, III / 2 / FG / T6								
	Entity Parameters US		Vmax=25V, Imax=600mA, Pi=1.25W, Ci=0, Li=0; NIFW: Vmax=25V, Imax=600mA, Ci=0, Li=0								
	Entity Parameters Canada		Vmax=25V, Imax=600mA, Pi=1.25W, Ci=0, Li=0; NIFW: Vmax=25V, Imax=600mA, Ci=0, Li=29µH								
	System Drawing No, USA		72184367								
	System Drawing No, Canada		72189337								
Excitation Voltage	Recommended	V AC/DC	5~15								
	Max.		20								
Terminal Resistance	Excitation	Ω	≥ 383								
	Output		350 ± 1								
Insulation Resistance @50VDC		MΩ	> 5000								
Breakdown Voltage		V AC	> 500								
Material	Spring Element		stainless steel								
	Enclosure		316 stainless steel								
	Cable entry fitting		304 stainless steel								
	Cable		PVC								

Parameter		unit of measure	Specification			
Protection	Type		welded			
	IP Rating		IP 68, IP69K			
	NEMA Rating		NEMA 6/6P			
Load Limit	Safe	%R.C.	150			
	Ultimate		300			
Safe Side Load		%R.C.	100			
Safe Dynamic Load		%R.C.	70			
Fatigue Life		cycles @R.C.	>1,000,000			
Direction of Loading			beam			
Deflection @ R.C., nominal		mm (in)	0.25 (0.01)	0.36 (0.014)	0.43 (0.017)	0.59 (0.023)
Weight, nominal		kg (lb)	0.6 (1.3)			
Cable	Length	m (ft)	3 (9.8) / 5 (16.4)			
	Diameter	mm (in)	5.8 (0.23)			
Mounting Screw	Grade		8.8 (grade 5) or 10.9 (grade 8)			
	Size/thread	mm (in)	M8x1.25 (5/16-18 UNC)			M10x1.5 (3/8-16 UNC)
	Torque, nominal	N.m (ft-lb)	15 (13)			20 (23)
Drawing No.	Dimensions		TB601173			
	To-Scale		TA601199			

1) Error due to the combined effect of non-linearity and hysteresis

2) Typical values only. The sum of errors due to Combined Error and Temperature Effect on Sensitivity comply with the requirements of OIML R60 and NIST HB44.

3) A.L. = Applied Load

4) See certificate for complete information.

5) 60 minutes

6) / m Load Cell Cable



## MTB Load Cell Dimensional Drawings mm [in]

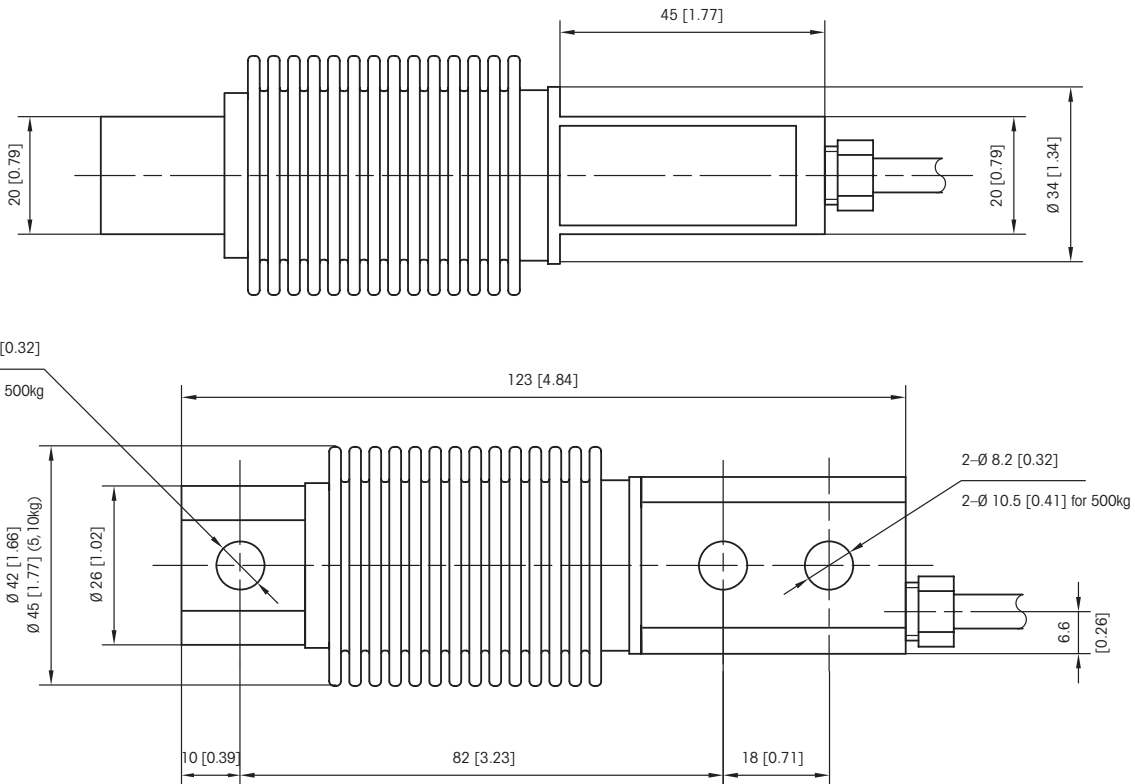

MTB 5, 10, 20, 50, 100, 200, 300, 500

## MTB Expansion Kit EK mm [in]

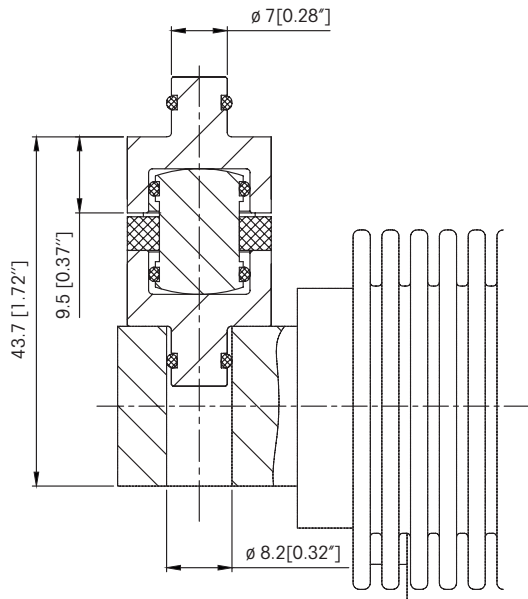

## MTB Spacer mm [in]

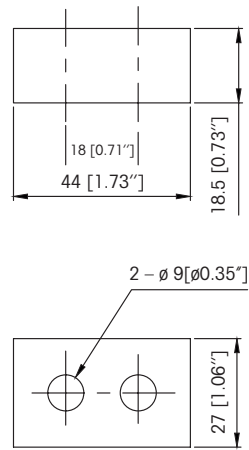

## MTB Expansion + Vibration Kit EVK mm [in]

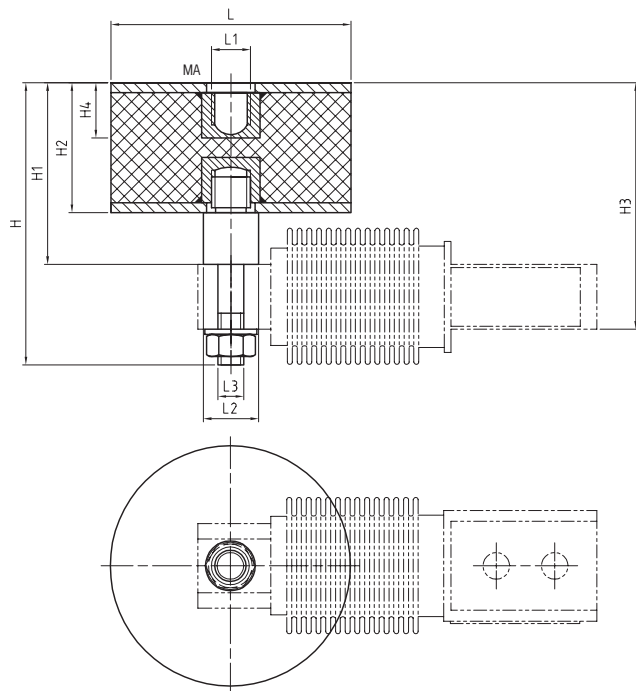

Materials: Stainless steel, NBR 70

### Capacity

### Dimensions and Locations

	L	L1	L2	L3	H	H1	H2	H3	H4	Smax <sup>1</sup>	Fs max <sup>2</sup>	Ft <sup>3</sup>	MA
5-300 kg	74 [2.91]	M12	17 [0.67]	M8	87 [3.43]	56 [2.20]	40 [1.57]	76 [2.99]	14 [0.55]	±3 [±0.12]	450 N	500 N	20 Nm [14.5 lb-ft]
500 kg	74 [2.91]	M12	17 [0.67]	M10	87 [3.43]	56 [2.20]	40 [1.57]	76 [2.99]	14 [0.55]	±3 [±0.12]	450 N	500 N	20 Nm [14.5 lb-ft]

1) Max lateral displacement

2) Max lateral force of Smax

3) Max Tension Force

## MTB Foot Kit FTK mm [in]

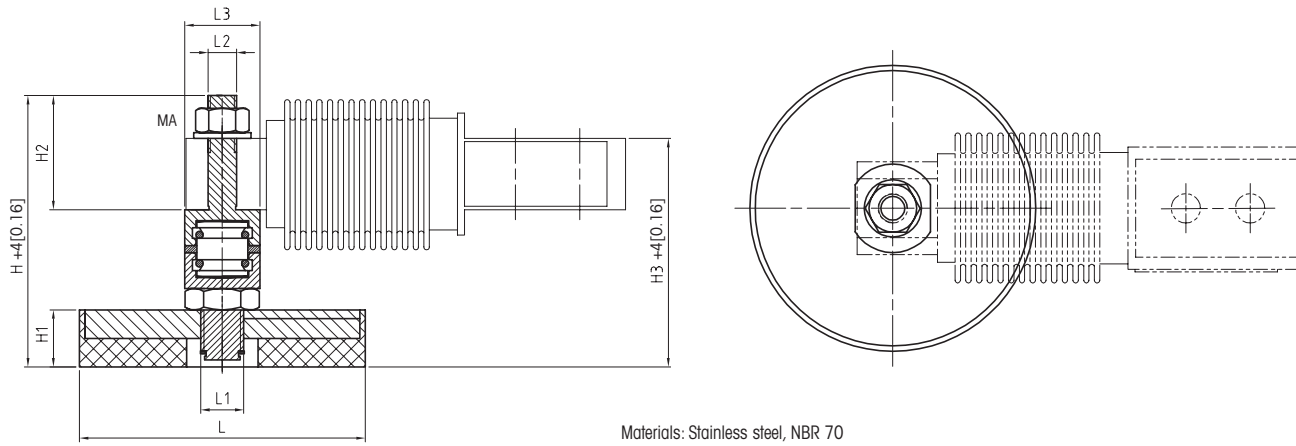

Capacity	Dimensions and Locations								
	L	L1	L2	L3	H	H1	H2	H3	MA
5-300 kg	ø80 [ø3.15]	M12	M8	21 [0.83]	76 [2.99]	16 [0.63]	32 [1.26]	64 [2.52]	20 Nm [14.5 ft-lb]
500 kg	ø80 [ø3.15]	M12	M10	21 [0.83]	76 [2.99]	16 [0.63]	32 [1.26]	64 [2.52]	20 Nm [14.5 ft-lb]

## MTB Base Plate Kit BPK mm [in]

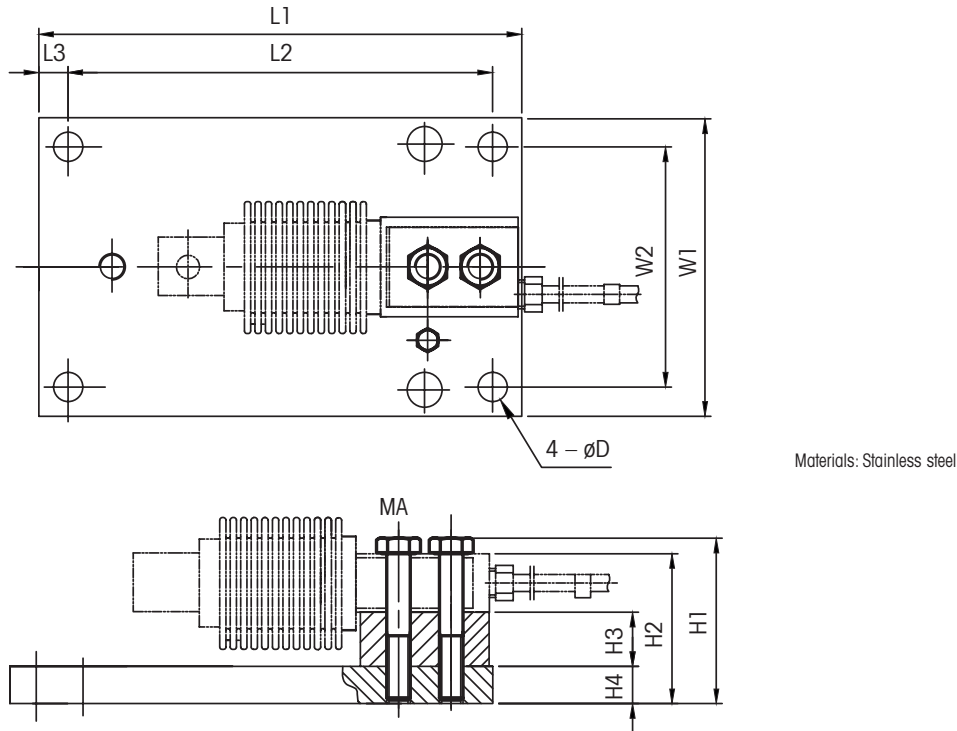

Capacity	Dimensions and Locations											
	L1	L2	L3	W1	W2	H1	H2	H3	H4	D	MA <sup>cs</sup> <sup>1</sup>	MA <sup>ss</sup> <sup>2</sup>
5-300 kg	165 [6.5]	145 [5.7]	10 [0.]	102 [4.0]	82 [3.2]	56.5 [2.22]	51.2 [2.02]	18.5 [0.73]	12.7 [0.5]	10 [0.4]	17 Nm [12.5 lb-ft]	17 Nm [12.5 lb-ft]

1 Torque carbon steel version  
2 Torque stainless steel version

## MTB Load Cell Order Information

Order Information		Item No., Load Cell		Item No., Options									
Rated Capacity	Class	Cable, Material / Length		Expansion Kit EK	Spacer	Base Plate Kit BPK, 304	Expansion+Vibr Kit EVK	Foot Kit FTK					
		PVC / 3 m (9.8 ft)	PVC / 5 m (16.4 ft)										
5kg / 11lb	0.05%	<b>71209934</b>	72208033	30265375	30265376	30265368	72208678	72208680					
10kg / 22lb	C3 / III S n:3 / III M n:5	<b>71209642</b>	72208034										
20kg / 44lb	C3 / III S n:3 / III M n:5	<b>71201556</b>	72208035										
30kg / 66lb	C6	<b>30212721</b>	30226939										
50kg / 110lb	C3 / III S n:3 / III M n:5	<b>71201557</b>	72208036										
	C6	<b>30212722</b>	30226940										
100kg / 220lb	C3 / III S n:3 / III M n:5	<b>71201558</b>	72208037										
	C6	<b>30212723</b>	30226941										
200kg / 441lb	C3 / III S n:3 / III M n:5	<b>71201559</b>	72208038										
	C6	<b>30212724</b>	30226942										
300kg / 661lb	C3 / III S n:3 / III M n:5	<b>71201560</b>	72208039										
	C6	<b>30212725</b>	30226943										
500kg / 1102lb	C3 / III S n:3 / III M n:5	<b>71209472</b>	72208040						–	–	–	<b>72208679</b>	<b>72208681</b>

## MTB Load Cell Cable Colours

Colour	Function
Green	+ Excitation
Black	– Excitation
White	+ Signal
Red	– Signal
Yellow	+ Sense
Blue	– Sense
Yellow (Long)	Shield

## Global Approvals

The MTB is provided with all listed approvals. No need to think about options and additional charges. Simplifies the conduct of global business, order processing and service-part stocking.



## Weighing Electronics

METTLER TOLEDO offers a complete family of electronics from simple weighing to application solutions for filling, stock control, batching, formulation, counting, checkweighing.



## METTLER TOLEDO Service

Our extensive service network is among the best in the world and ensures maximum availability and service life of your product.



### Mettler-Toledo GmbH

Industrial Division  
CH-8606 Nänikon, Switzerland  
Tel. + 41 44 944 22 11

Local contact: [www.mt.com/contacts](http://www.mt.com/contacts)

Subject to technical changes  
© 12/2021 Mettler-Toledo GmbH  
MTSI 44099191

[www.mt.com](http://www.mt.com)

For more information