

## Superior Accuracy Control Your Process Anytime



### Superior Accuracy

SLB615D POWERCELL® provides extremely high accuracy up to OIML C10 which is three times better than usual. The internal micro processor compensated environmental impacts on the fly.



### Tank Weighing

The capacity range from 220kg to 4.4t allows the weighing of tanks and silos. The stainless steel design, hermetic sealing and IP68/IP69K protection provides the best reliability in tank and hopper weighing applications.



### PowerMount Weigh Module

The optional METTLER TOLEDO PowerMount weigh module allows one to convert an existing system into a precise weighing system. It is ideal for applications such as tanks scales, belt scales and conveyor scales. Available in zinc plated steel or stainless steel.



### Predictive Maintenance

SLB615D monitors single load cells for overload, zero drift, foundation problems, etc.; prompting action before system shuts down or measures incorrectly.



### SLB615D POWERCELL®

Know What's Ahead

The SLB615D POWERCELL® is approved for use in various applications in Europe, Asia, America and almost everywhere else in the world. If an approval is required, the SLB615D POWERCELL® already complies.

Every SLB615D beam load cell features:

- Micro processor controlled accuracy
- Robust output signal
- 10V/m EMC protection
- No junction box connections
- OIML C3, C6, C10 accuracy
- NTEP II M 5K, 10K accuracy
- ATEX Zone 2/22 approvals
- FM Class I, II, III Div.2 approvals for USA & Canada
- Stainless steel
- IP68, IP69K protection class

# SLB615D POWERCELL® Specifications

Parameter		Unit of measure	Specification													
Model No.			SLB615D POWERCELL® (5)													
Rated capacity (R.C.)		kg (lb, nominal)	220 (500)		550 (1250)		1100 (2500)		2200 (5000)		4400 (10000)					
External resolution		Counts @ R.C.	220,000		550,000		1,100,000		2,200,000		440,000					
Min. increment size, typical (7)(8)		g (lb)	4.4 (0.01)		11 (0.025)		22 (0.05)		44 (0.1)		88 (0.2)					
Zero load output		%R.C.	< 0.1													
Combined error (1)(2)		%R.C.	C3/III n:5: ≤ 0.018 / C6/III n:10: ≤ 0.012 / C10: ≤ 0.007													
Repeatability error		%A.L (3)	C3/III n:5: ≤ 0.01 / C6/III n:10: ≤ 0.005 / C10: ≤ 0.003													
Creep, 30 minute		%A.L.	C3/III n:5: ≤ 0.017 / C6/III n:10: ≤ 0.008 / C10: ≤ 0.005													
Min. dead load output return (DR), 30 min.		%A.L.	C3/III n:5: ≤ 0.017 / C6/III n:10: ≤ 0.008 / C10: ≤ 0.005													
Temperature effect on	Min. dead load output	%RC, °C (°F)	0.0014 (0.0008)	C3/III n:5: ≤ 0.0011 (0.0006) / C6/III n:10: ≤ 0.0007 (0.0004) / C10: ≤ 0.0007 (0.0004)											0.0009 (0.0006)	
	Sensitivity (2)	%AL, °C (°F)	C3/III n:5: ≤ 0.001 (0.0006) / C6/III n:10: ≤ 0.0005 (0.0003) / C10: ≤ 0.0003 (0.0002)													
Temperature range	Compensated	°C (°F)	-10 ~ +40 (+14 ~ +104)													
	Operating		-20 ~ +65 (-4 ~ +150)													
	Safe storage		-40 ~ +80 (-40 ~ +176)													
OIML / European approval (4)	Number, OIML / Europe		R60/2000-CN1-13.01 / NMI TC8489													
	Class		C3	O6	C10	C3	O6	C10	C3	O6	C10	C3	O6	C10	C3	O6
	nmax		3000	6000	110000	3000	6000	10000	3000	6000	10000	3000	6000	10000	3000	6000
	Vmin	g	20	10	37	25	70	50	150	100	290	250				
	PLC		0.8													
	Humidity symbol		CH													
	Min. dead load	kg	0													
	Z		3000	6000	10000	3000	6000	10000	3000	6000	10000	3000	6000	10000	3000	600
	Barometric pressure effect		None													
	NTEP approval (4)	Number		13-118												
Class			III M n:5	III M n:10	-	III M n:5	III M n:10	-	III M n:5	III M n:10	-	III M n:5	III M n:10	-	III M n:5	III M n:10
nmax			5000	10000	-	5000	10000	-	5000	10000	-	5000	10000	-	5000	10000
Vmin		lb	0.05	0.025	-	0.095	0.065	-	0.19	0.13	-	0.38	0.26	-	0.76	0.65
Min. dead load		lb	0													
ATEX approval (4)	Number, cat. 2		FM17ATEX0023													
	Rating		II 2 G Ex ib IIB T4 Gb / II 2 D Ex ib IIIC T130C Db / -40°C ≤ Ta ≤ +55°C													
	Entity Parameters		Ui = 8.4V, li = 100 mA, Pi = 0.84W, Ci = 5.3 uF, Li = 0 uH (7)													
	Number, cat. 3		DEKRA 14ATEX0030													
	Rating		II 3 G Ex nA IIC T6 Gc / II 3 D Ex tc IIIC T85 °C Dc													
Entity parameters		Umax = 28V, Imax = 50mA, Pmax = 0.5W (7)														
IECEx approval (4)			Ex ib IIB T4 Gb / Ex ib IIIC T130°C Db / Ex nA IIC T6 Gc / Ex ec IIC T6 Gc / Ex tc IIIC T85°C Dc													
Factory Mutual Approval	Number, USA / Canada		FM17US0025 / FM17CA0013													
	Rating, USA		IS / I, II, III / I / CDEFG / T4 Ta = -40°C to 55°C ; I / I / AEx ib / IIB / T4 Ta = -40°C to 55°C / Gb ; 21 / AEx ib / IIIC / T130°C Ta = -40°C to 55°C / Db													
	Rating, Canada		IS / I, II, III / I / CDEFG / T4 Ta = -40°C to 55°C ; I / I / AEx ib / IIB / T4 Ta = -40°C to 55°C / Gb ; 21 / AEx ib / IIIC / T130°C Ta = -40°C to 55°C / Db													
	Entity Parameters	Division 1	Ui (Vmax) = 8.4V, li (Imax) = 100 mA, Pi = 0.84W, Ci = 5.3 uF, Li = 0 uH													
	System Drawing No, USA		30343371													
	System Drawing No, Canada		30343371													

Parameter		Unit of measure	Specification				
Factory Mutual Approval	Number, USA / Canada	Division 2	FM17US0281 / FM17CA0143				
	Rating, USA		NI / I, II, III / 2 / ABCDFG / T6 -40°C ≤ Ta ≤ 55°C				
	Rating, Canada		NI / I, II, III / 2 / ABCDFG / T6 -40°C ≤ Ta ≤ 55°C				
	Entily Parameters		Vmax = 13.7V, Imax = 2000mA, Ci = 0.3nF, Li = 0				
	System Drawing No, USA		30095703				
	System Drawing No, Canada		30095703				
Insulation Resistance @50VDC		MΩ	≥ 2000				
Breakdown Voltage		V AC	≥ 500				
Supply Voltage Non-regulated	Range (nominal)	V DC	10 ~ 26				
	Typical		12 / 24				
Supply current	Max.	mA	150				
	Typical		20				
Overvoltage protection	Max. tested (IEEE4-95)	A	2000 (no outdoor lightning conditions)				
Warm-up time from cold start		Minutes	15				
Communications	Type	Controller area network (CAN), Encrypted					
	Protocol	Can open					
Effective system update rate (4 load cells)		Hz	40				
ESD rating		kV	8				
Span stability, typical (peak to peak in 1 min)		Counts	15				
Immunity	OIML R60	Vm	10				
Material	Spring element	Stainless steel					
	Enclosure	304 Stainless steel, electropolished					
	Connectors	Stainless steel					
	Cable	Polyurethane (PU)					
Protection	Type	0	Welded				
	IP rating	0	IP68, IP69K				
	NEMA rating	0	NEMA 6/6P				
Overload protection	0	0	Yes	No			
Load limit	Safe	%R.C.	150				
	Ultimate	0	300				
Safe side load		%R.C.	100				
Safe dynamic load		%R.C.	70				
Fatigue life		cycles @R.C.	> 1,000,000				
Direction of loading		0	Beam				
Deflection @ R.C., nominal		mm (in)	0.16 (0.006)	0.25 (0.010)	0.32 (0.013)	0.43(0.017)	0.72 (0.028)
Weight, nominal		kg (lb)	1 (2.2)			1.3 (2.9)	2.2 (4.8)
Cable	Load cell cable <sup>6)</sup>	Polyurethane, 11mm Connector, 21mm Branch Housing (200mm Distance to LC), Req. Conduit ≥12mm (0.5")					
	Home-run cable <sup>6)</sup>	Polyurethane, 6mm jacket, 21mm branch housing (200mm distance to LC), 4 conductors, internal shield with drain wires, req. conduit ≥12mm(0.5")					
Connectors		Quick-Connect					
Grade		10.9 (Grade 8)					
Mounting Screw	Size/thread	M12 (1/2-13 UNC)				M18x1,5 (3/4-10 UNC)	
	Torque, nominal	98 (72)				275 (220)	

<sup>1)</sup> Error due to the combined effect of non-linearity and hysteresis

<sup>2)</sup> Typical values only. The sum of errors due to combined error and temperature effect on sensitivity comply with the requirements of OIML R60 and NIST HB44.

<sup>3)</sup> A.L. = Applied Load

<sup>4)</sup> See certificate for complete information.

<sup>5)</sup> Max. 14 load cells / terminal

<sup>6)</sup> Max. total cable length 90-300m depending on no. of LC and terminal.

<sup>7)</sup> / Load cell

<sup>8)</sup> Calculate the scale's minimum increment size by multiplying this value by the square root of the number of load cells. For non Legal-For-Trade Applications



SLB615D POWERCELL® Dimensional Drawings mm [inch]

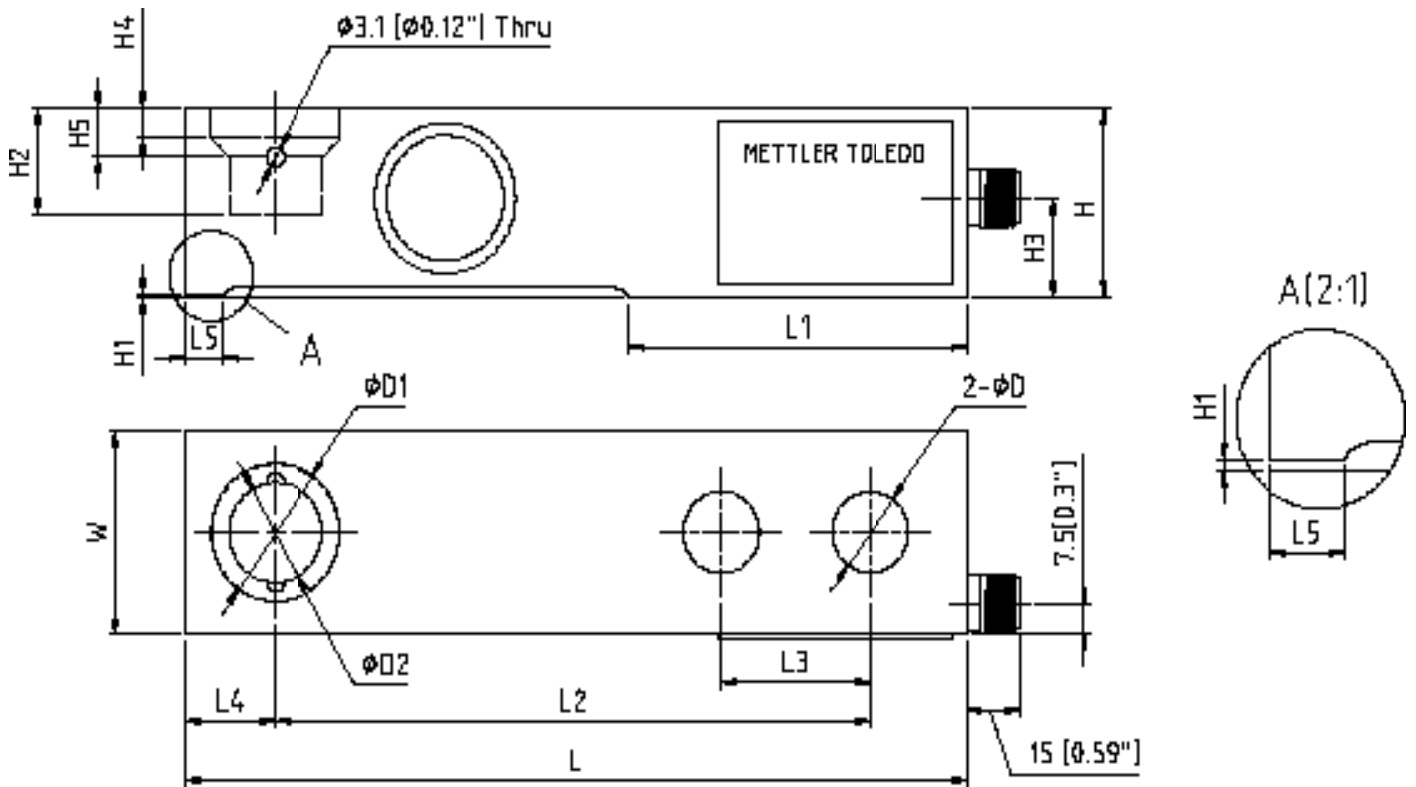

Notes:

1. Dimensions are in mm [inches]

Capacity	Dimensions															
	D	D1	D2	H	H1	H2	H3	H4	H5	L	L1	L2	L3	L4	L5	W
<b>220/550/1100 kg</b> <b>[500/1250/2500 lb]</b>	13.0 [0.51]	22.2 [0.87]	15.9 [0.63]	30.2 [1.19]	0.38/0.38/0.51 [0.015]/[0.015]/[0.02]	17.0 [0.67]	16.0 [0.63]	4.7 [0.19]	7.7 [0.30]	134.4 [5.29]	57.7 [2.27]	1016 [4.00]	25.4 [1.00]	16.4 [0.65]	6.4 [0.25]	32.7 [1.29]
<b>2200 kg</b> <b>[5000 lb]</b>	13.0 [0.51]	22.2 [0.87]	15.9 [0.63]	36.6 [1.44]	4 [0.158]	22.9 [0.90]	20.3 [0.80]	9.5 [0.37]	12.7 [0.50]	136.7 [5.38]	57.9 [2.28]	1016 [4.00]	25.4 [1.00]	18.4 [0.72]		36.8 [1.45]
<b>4400 kg</b> <b>[10000 lb]</b>	19.3 [0.76]	34.9 [1.37]	22.2 [0.87]	42.9 [1.69]	2.3 [0.091]	29.3 [1.15]	22.6 [0.90]	11 [0.43]	17.4 [0.69]	171.5 [6.75]	73.8 [2.91]	133.3 [5.25]	38.1 [1.50]	21.5 [0.85]		42.9 [1.69]

## SLB615D POWERCELL® Foot Kit FTK mm [inch]

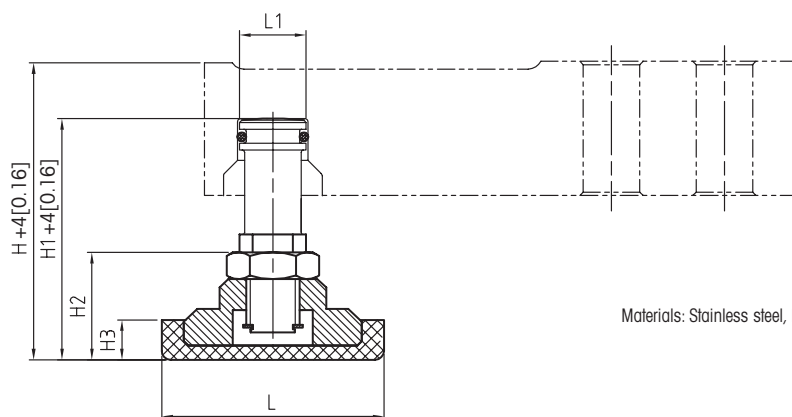

Materials: Stainless steel, NBR 70

Capacity	Dimensions and locations					
	L	L1	H	H1	H2	H3
220 kg-1.1 t	ø50 [ø1.97]	ø15 [ø0.59]	66.8 [2.14]	54.3 [2.14]	24.2 [0.95]	9 [0.35]
2.2 t	ø50 [ø1.97]	ø15 [ø0.59]	66.5 [2.14]	54.3 [2.14]	24.2 [0.95]	9 [0.35]
4.4 t	ø70 [ø2.76]	ø15 [ø0.59]	91.2 [3.59]	80 [3.15]	38.5 [1.52]	17 [0.67]

## SLB615D POWERCELL® Expansion Kit EK mm [inch]

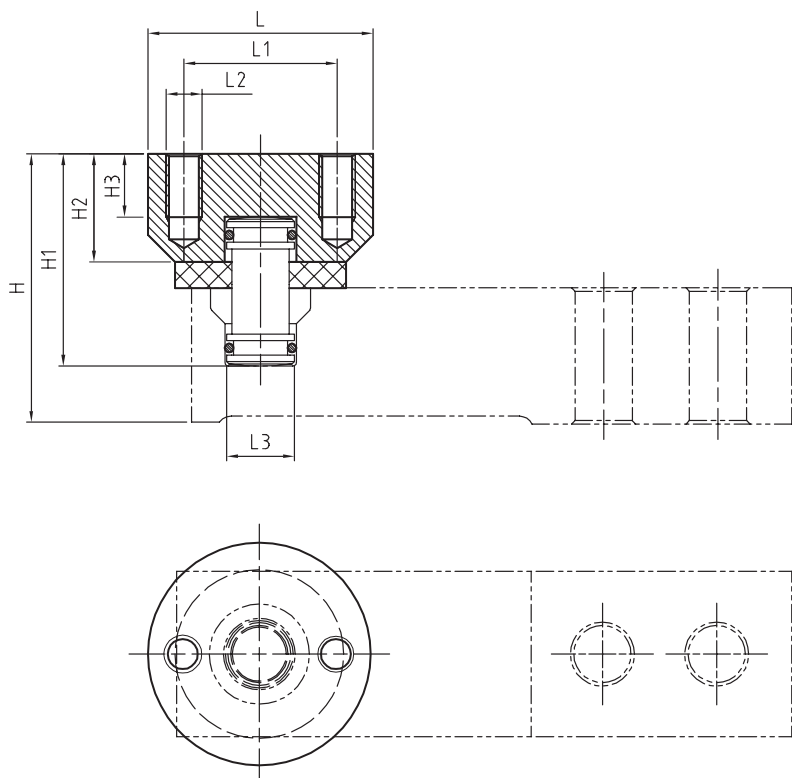

Materials: Stainless steel, polyethylene foam

Capacity	Dimensions and locations									
	L	L1	L2	L3	H	H1	H2	H3	Smax*	
220 kg-1.1 t	ø50 [ø1.97]	34 [1.34]	M8	ø15 [ø0.59]	59.6 [2.35]	47.1 [1.85]	24 [0.94]	14 [0.55]	±3 mm [±0.12]	
2.2 t	ø50 [ø1.97]	34 [1.34]	M8	ø15 [ø0.59]	63.5 [2.50]	52.3 [2.06]	24 [0.94]	14 [0.55]	±3 mm [±0.12]	
4.4 t	ø60 [ø2.36]	45 [1.77]	M10	ø21.5 [ø0.85]	73.6 [2.90]	62.4 [2.46]	28 [1.10]	17 [0.67]	±3 mm [±0.12]	

\* Max. lateral displacement

## SLB615D POWERCELL® Expansion + Vibration Kit EVK mm [inch]

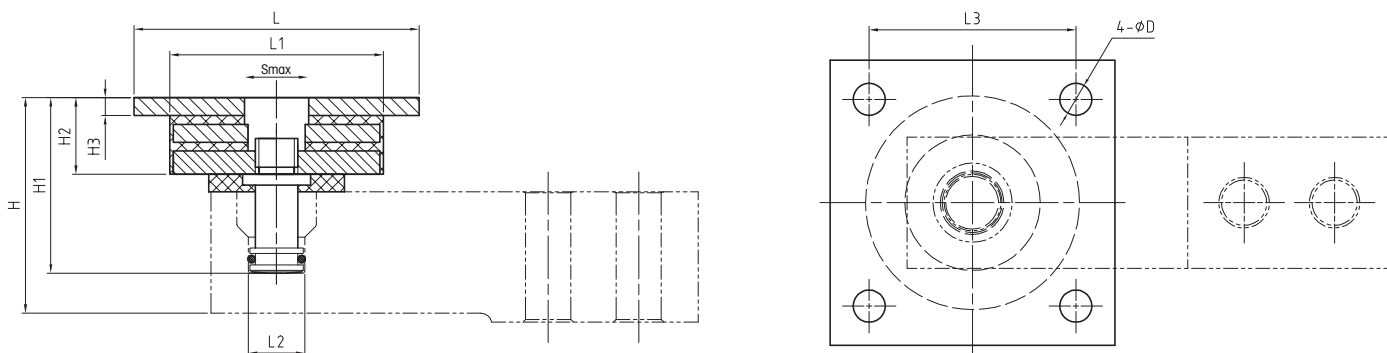

Materials: Stainless steel, NBR 70, polyethylene foam

Capacity	Dimensions and locations										
	D	L	L1	L2	L3	H	H1	H2	H3	SHmax*	SVmax**
220 kg-1.1 t	ø9 [ø0.35]	ø80 [ø3.15]	ø58 [ø2.28]	ø15 [ø0.59]	58 [2.28]	56.6 [2.23]	44.1 [1.74]	21.5 [0.85]	5 [0.20]	±2.8 mm [±0.11]	1 mm [0.04]
2.2t	ø9 [ø0.35]	ø80 [ø3.15]	ø58 [ø2.28]	ø15 [ø0.59]	58 [2.28]	60.5 [2.38]	49.3 [1.94]	21.5 [0.85]	5 [0.20]	±3 mm [±0.12]	1.6 mm [0.07]
4.4t	ø11 [ø0.43]	ø100 [ø3.94]	ø72 [ø2.83]	ø21.5 [ø0.85]	76 [2.99]	75.6 [2.98]	64.4 [2.54]	30 [1.18]	10 [0.39]	±3 mm [±0.12]	2.2 mm [0.09]

\* Max. lateral displacement \*\* Max. vertical displacement incl. load cell

## SLB615D POWERCELL® Base Plate Kit BPK mm [inch]

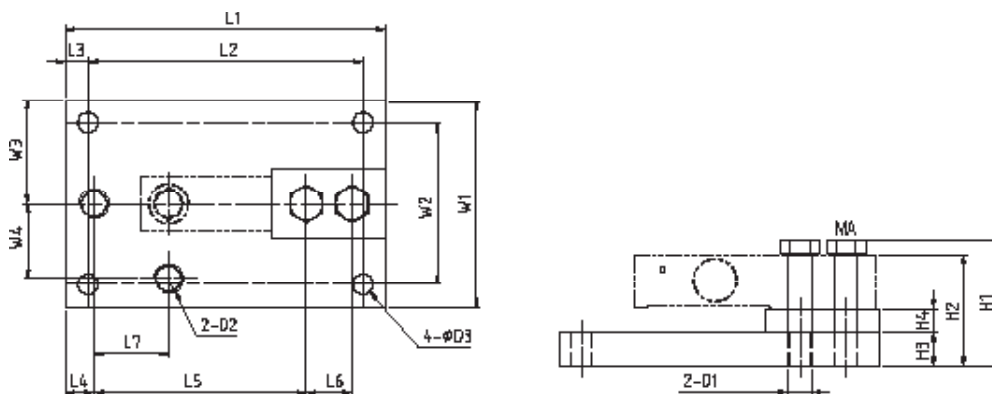

Materials: Stainless steel or painted steel

Capacity	Dimensions and locations										
	L1	L2	L3	L4	L5	L6	L7	W1	W2	W3	W4
220 kg-1.1 t	177.8 [7]	152.4 [6]	12.7 [0.5]	16.0 [0.63]	117.6 [4.63]	25.4 [1]	41.4 [1.63]	114.3 [4.5]	88.9 [3.5]	57.2 [2.25]	41.4 [1.63]
2.2t	177.8 [7]	152.4 [6]	12.7 [0.5]	16.0 [0.63]	117.6 [4.63]	25.4 [1]	41.4 [1.63]	114.3 [4.5]	88.9 [3.5]	57.2 [2.25]	41.4 [1.63]
4.4t	235.0 [9.25]	184.2 [7.25]	25.4 [1]	22.4 [0.88]	149.4 [5.88]	38.1 [1.5]	54.1 [2.13]	152.4 [6]	101.6 [4]	76.2 [3]	54.1 [2.13]

Capacity	Dimensions and locations									
	H1	H2	H3	H4	D1	D2	D3	MA cs <sup>1</sup>	MA ss <sup>2</sup>	
220 kg-1.1 t	70.2 [2.76]	62.0 [2.44]	19.1 [0.75]	12.7 [0.5]	M12	M16	11.2 [0.44]	136 Nm [100lb-ft]	100 Nm [75lb-ft]	
2.2t	76.5 [3.01]	68.4 [2.96]	19.1 [0.75]	12.7 [0.5]	M12	M16	11.2 [0.44]	136 Nm [100lb-ft]	100 Nm [75lb-ft]	
4.4t	99.6 [3.92]	87.4 [3.44]	25.4 [1]	19.1 [0.75]	M18	M18	17.5 [0.69]	340 Nm [250lb-ft]	270 Nm [200lb-ft]	

1) Torque carbon steel version 2) Torque stainless steel version

## SLB615D POWERCELL® Order Information

Rated capacity	Item No., load cell			Item No., Options					
	Class			Base Plate Kit BPK, CS	Base Plate Kit BPK, 304	Expansion Kit EK	Expansion+ Vibr Kit EVK	Foot Kit FTK	Adapter, Conduit
	C3/III M n:5	C6/III M n:10	C10						
220kg / 500lb	30450308	30450311	30450314	30265369	30265370	72208662	72208670	72208674	30095581
550kg/1.25klb	30450317	30450320	30450323						
1100kg / 2500lb	30450326	30450329	30450332						
2200kg / 5000lb	30450335	30450338	30539636	30265371	30265372				
4400kg / 10000lb	30450344	30450347	-	30265373	30265374	72208663	72208671	72208675	

## SLB615D POWERCELL® Order Information, Cables

Description	Item No.								
	Cable, material / length								
	PU/2.5m (8.2ft)	PU/5m (16.4ft)	PU/10m (32.8ft)	PU/15m (49.2ft)	PU/20m (65.6ft)	PU/30m (98.4ft)	PU/50m (164ft)	PU/100m (328ft)	PU/200m (656ft)
Cable kit, 3 load cells	30382994	30382990	30382991	-	-	-	-	-	-
Cable kit, 4 load cells	30382995	30382992	30382993	-	-	-	-	-	-
Load cell Y-Cable	30382975	30382976	30382977	-	-	-	-	-	-
Home run cable	-	30382980	30382981	30382982	30382983	30382984	30382985	30382986	30423113
Extension cable	-	30382987	30382988	-	-	-	-	-	-
CAN termination	30382989								
Blind plug	30417485								
Cable gland for home run cable with IND780PDX	30095639								

## SLB615D POWERCELL® Home Run Cable

Colour	Function
Yellow	Shield
Blue	CAN_L
White	CAN_H
Red	V+
Black	V-

### Global Approvals

The SLB615D is provided with all listed approvals. No need to think about options and additional charges. Simplifies the conduct of global business, order processing and service-part stocking.



### METTLER TOLEDO Service

Our extensive service network is among the best in the world and ensures maximum availability and service life of your product.



### Weighing Electronics

METTLER TOLEDO offers a complete family of electronics from simple weighing to application solutions for filling, stock control, batching, formulation, counting, checkweighing.

#### METTLER TOLEDO Group

Industrial Division  
Local contact: [www.mt.com/contacts](http://www.mt.com/contacts)

Subject to technical changes  
© 05/2021 METTLER TOLEDO.  
All rights reserved  
Document No. 30242889 A  
MarCom Industrial

[www.mt.com](http://www.mt.com)

For more information

