

Overview



Milltronics MWL weight lifter is a mechanical calibration weight lifter for MCS, MSI, MMI, and MUS belt scales.

Benefits

- Safe and easy application of belt scale reference weights with the operator remaining external to the conveyor
- Modular construction, easily adaptable to different conveyor widths
- Low profile allowing easy fit into belt conveyor
- Easy to install and apply
- Easy to store drive handle that can be applied to left or right side of MWL
- Security pin used to ensure safe storage of weight
- Can be used with new and existing applications

Application

Milltronics MWL mechanically raises and lowers the static weights and then stores the weights securely above the belt scale calibration arms, and allows the operator to lower and apply them safely without having to lean into the conveyor. The MWL is manually operated, and uses a high mechanical advantage to enable weights up to 340 kg (750 lb) to be applied with very limited effort. The crank handle uses twelve rotations for full range of motion, and can be removed and stored for safety with the locking ball-pin which secures the MWL when it is not in use.

Two lifting arms support a base-bar weight above the calibration (test) weight brackets of the belt scale: either flat bar or round bar style calibration weights are applicable. Locating notches in the base-bar weight engage the calibration weights securely on the lifting arms in the stored position, and the gear drive locks the lifting arms in place.

Installation is easy, just four bolt holes to drill after locating the MWL gear modules (LH and RH) on the conveyor with respect to the belt scale. After running the MWL empty to ensure proper alignment, and then tightening mounting bolts, you are ready for the loading of the calibration weights. This is the last time that they will have to be lifted by hand.

Technical specifications

Milltronics MWL weight lifter	
Mode of operation	
Principle of operation	Mechanical gear drive
Typical application	Belt scale calibration
Medium conditions	
Max. ambient temperature	75 °C (167 °F)
Belt design	
Belt width	<ul style="list-style-type: none"> • MCS: up to 1 600 mm (60 inch) CEMA width • MUS-STD standard duty: up to 1 000 mm (42 inch) CEMA width • MUS-HD heavy-duty: up to 1 600 mm (60 inch) CEMA width • MSI: 18 ... 96 inch CEMA belt width
Conveyor incline	
	± 15° from horizontal
Idlers	
Idler spacing	20° or more troughed idlers
Calibration weight capacity	
	Up to 340 kg (750 lb)
Crank arm	
Mechanical advantage	20:1
Number of revolutions required for raising or lowering	12
Mounting dimensions	
	See reverse for standard and heavy-duty MUS, MCS, and MSI/MMI belt scales
Approvals	
	The MWL is in compliance with directive 98/37/EC, CE, RCM
Motorized option	CE, RCM, EAC, KCC, CSA _{C/US}

Belt Weighing Accessories

Calibration weight lifter Milltronics MWL

Selection and ordering data

Milltronics MWL Calibration weight lifter

Mechanical calibration weight lifter designed for use with MSI, MMI, MCS, and MUS belt scales

➤ Click on the Article No. for the online configuration in the PIA Life Cycle Portal.

Actuation

Manually

Belt width and 'A' dimension

18 inch, 'A'=27 inch (686 mm)	AA
19 inch, 'A'=28 inch (711 mm)	AB
20 inch, 'A'=29 inch (737 mm)	AC
21 inch, 'A'=30 inch (762 mm)	AD
22 inch, 'A'=31 inch (787 mm)	AE
23 inch, 'A'=32 inch (813 mm)	AF
24 inch, 'A'=33 inch (838 mm)	AG
25 inch, 'A'=34 inch (864 mm)	AH
26 inch, 'A'=35 inch (889 mm)	AJ
27 inch, 'A'=36 inch (914 mm)	AK
28 inch, 'A'=37 inch (940 mm)	AL
29 inch, 'A'=38 inch (965 mm)	AM
30 inch, 'A'=39 inch (991 mm)	AN
31 inch, 'A'=40 inch (1 016 mm)	AP
32 inch, 'A'=41 inch (1 041 mm)	AQ
33 inch, 'A'=42 inch (1 067 mm)	AR
34 inch, 'A'=43 inch (1 092 mm)	AS
35 inch, 'A'=44 inch (1 118 mm)	AT
36 inch, 'A'=45 inch (1 143 mm)	AU
37 inch, 'A'=46 inch (1 168 mm)	AV
38 inch, 'A'=47 inch (1 194 mm)	AW
39 inch, 'A'=48 inch (1 219 mm)	BA
40 inch, 'A'=49 inch (1 245 mm)	BB
41 inch, 'A'=50 inch (1 270 mm)	BC
42 inch, 'A'=51 inch (1 295 mm)	BD
43 inch, 'A'=52 inch (1 321 mm)	BE
44 inch, 'A'=53 inch (1 346 mm)	BF
45 inch, 'A'=54 inch (1 372 mm)	BG
46 inch, 'A'=55 inch (1 397 mm)	BH
47 inch, 'A'=56 inch (1 422 mm)	BJ
48 inch, 'A'=57 inch (1 448 mm)	BK
49 inch, 'A'=58 inch (1 473 mm)	BL
50 inch, 'A'=59 inch (1 499 mm)	BM
51 inch, 'A'=60 inch (1 524 mm)	BN
52 inch, 'A'=61 inch (1 549 mm)	BP
53 inch, 'A'=62 inch (1 575 mm)	BQ
54 inch, 'A'=63 inch (1 600 mm)	BR
55 inch, 'A'=64 inch (1 626 mm)	BS
56 inch, 'A'=65 inch (1 651 mm)	BT
57 inch, 'A'=66 inch (1 676 mm)	BU
58 inch, 'A'=67 inch (1 702 mm)	BV
59 inch, 'A'=68 inch (1 727 mm)	BW
60 inch, 'A'=69 inch (1 753 mm)	CA
61 inch, 'A'=70 inch (1 778 mm)	CB
62 inch, 'A'=71 inch (1 803 mm)	CC
63 inch, 'A'=72 inch (1 829 mm)	CD
64 inch, 'A'=73 inch (1 854 mm)	CE

Article No.

7MH7218-

Milltronics MWL Calibration weight lifter

Mechanical calibration weight lifter designed for use with MSI, MMI, MCS, and MUS belt scales

65 inch, 'A'=74 inch (1 880 mm)	CF
66 inch, 'A'=75 inch (1 905 mm)	CG
67 inch, 'A'=76 inch (1 930 mm)	CH
68 inch, 'A'=77 inch (1 956 mm)	CJ
69 inch, 'A'=78 inch (1 981 mm)	CK
70 inch, 'A'=79 inch (2 007 mm)	CL
71 inch, 'A'=80 inch (2 032 mm)	CM
72 inch, 'A'=81 inch (2 057 mm)	CN
73 inch, 'A'=82 inch (2 083 mm)	CP
74 inch, 'A'=83 inch (2 108 mm)	CQ
75 inch, 'A'=84 inch (2 134 mm)	CR
76 inch, 'A'=85 inch (2 159 mm)	CS
77 inch, 'A'=86 inch (2 184 mm)	CT
78 inch, 'A'=87 inch (2 210 mm)	CU
79 inch, 'A'=88 inch (2 235 mm)	CV
80 inch, 'A'=89 inch (2 261 mm)	CW
81 inch, 'A'=90 inch (2 286 mm)	DA
82 inch, 'A'=91 inch (2 311 mm)	DB
83 inch, 'A'=92 inch (2 337 mm)	DC
84 inch, 'A'=93 inch (2 362 mm)	DD
85 inch, 'A'=94 inch (2 388 mm)	DE
86 inch, 'A'=95 inch (2 413 mm)	DF
87 inch, 'A'=96 inch (2 438 mm)	DG
88 inch, 'A'=97 inch (2 464 mm)	DH
89 inch, 'A'=98 inch (2 489 mm)	DJ
90 inch, 'A'=99 inch (2 515 mm)	DK
91 inch, 'A'=100 inch (2 540 mm)	DL
92 inch, 'A'=101 inch (2 565 mm)	DM
93 inch, 'A'=102 inch (2 591 mm)	DN
94 inch, 'A'=103 inch (2 616 mm)	DP
95 inch, 'A'=104 inch (2 642 mm)	DQ
96 inch, 'A'=105 inch (2 667 mm)	DR

No width parts³⁾

Weight type

None

For use with flat bar weights (weights not included)

Width based on belt width

3 inch integrated round bar weight (18 ... 29 inch, 15.9 ... 22.7 kg)	3 1
3 inch integrated round bar weight (30 ... 41 inch, 26.8 ... 33.6 kg)	3 2
3 inch integrated round bar weight (42 ... 53 inch, 37.7 ... 44.5 kg)	3 3
3 inch integrated round bar weight (54 ... 65 inch, 48.6 ... 58.6 kg)	3 4
3 inch integrated round bar weight (66 ... 77 inch, 59.5 ... 69.5 kg)	3 5
3 inch integrated round bar weight (78 ... 89 inch, 70.4 ... 80.4 kg)	3 6
3 inch integrated round bar weight (90 ... 96 inch, 81.3 ... 86.8 kg)	3 7
4 inch integrated round bar weight (18 ... 29 inch, 23.3 ... 34.3 kg)	4 1

Article No.

7MH7218-

CF
CG
CH
CJ
CK
CL
CM
CN
CP
CQ
CR
CS
CT
CU
CV
CW
DA
DB
DC
DD
DE
DF
DG
DH
DJ
DK
DL
DM
DN
DP
DQ
DR
XX

0 0

1 1

3 1

3 2

3 3

3 4

3 5

3 6

3 7

4 1

Selection and ordering data	Article No.	Order Code
Milltronics MWL Calibration weight lifter Mechanical calibration weight lifter designed for use with MSI, MMI, MCS, and MUS belt scales	7MH7218-	
4 inch integrated round bar weight (30 ... 41 inch, 42.7 ... 53.7 kg)	4 2	
4 inch integrated round bar weight (42 ... 53 inch, 62.1 ... 73.1 kg)	4 3	
4 inch integrated round bar weight (54 ... 65 inch, 81.5 ... 99.3 kg)	4 4	
4 inch integrated round bar weight (66 ... 77 inch, 100.9 ... 118.6 kg)	4 5	
4 inch integrated round bar weight (78 ... 89 inch, 120.3 ... 138.0 kg)	4 6	
4 inch integrated round bar weight (90 ... 96 inch, 139.6 ... 149.3 kg)	4 7	
5 inch integrated round bar weight (18 ... 29 inch, 32.9 ... 49.3 kg)	5 1	
5 inch integrated round bar weight (30 ... 41 inch, 63.2 ... 79.6 kg)	5 2	
5 inch integrated round bar weight (42 ... 53 inch, 93.5 ... 109.9 kg)	5 3	
5 inch integrated round bar weight (54 ... 65 inch, 123.7 ... 151.5 kg)	5 4	
5 inch integrated round bar weight (66 ... 77 inch, 154.0 ... 181.8 kg)	5 5	
5 inch integrated round bar weight (78 ... 89 inch, 184.3 ... 212.1 kg)	5 6	
5 inch integrated round bar weight (90 ... 96 inch, 214.6 ... 229.7 kg)	5 7	
6 inch integrated round bar weight (18 ... 29 inch, 44.5 ... 67.6 kg)	6 1	
6 inch integrated round bar weight (30 ... 41 inch, 88.2 ... 111.2 kg)	6 2	
6 inch integrated round bar weight (42 ... 53 inch, 131.8 ... 154.8 kg)	6 3	
6 inch integrated round bar weight (54 ... 65 inch, 175.4 ... 215.3 kg)	6 4	
6 inch integrated round bar weight (66 ... 77 inch, 219.0 ... 258.9 kg)	6 5	
6 inch integrated round bar weight (78 ... 89 inch, 262.6 ... 302.5 kg)	6 6	
6 inch integrated round bar weight (90 ... 96 inch, 306.2 ... 328.0 kg)	6 7	
Fabrication		
Standard, C5-M rated polyester painted mild steel	1	
Electro galvanized mild steel	2	
Other materials available upon request.		
		Further designs Please add "-Z" to article no. and specify order code(s). Stainless steel tag [69 x 38 mm (2.7 x 1.5 inch)]: measuring-point number/identification (max 27 characters), specify in plain text. Manufacturer's test certificate: According to EN 10204-2.2
		Operating instruction All literature is available to download for free, in a range of languages, at https://www.siemens.com/weighing/documentation
		Spare parts MWL handle shaft extension, 3.75 inch (95 mm) MWL module LH unit MWL module RH unit MWL handle MWL retrofit kit (for Milltronics MSI, MMI belt scales) MWL retrofit kit galvanized (for Milltronics MSI, MMI belt scales) MWL retrofit kit (for Milltronics MCS belt scales) MWL handle shaft extension galvanized [3.75 inch (95 mm)] MWL module LH unit galvanized MWL module RH unit galvanized MWL handle galvanized
		Article No. 7MH7226-1AM 7MH7223-1GU 7MH7223-1GV 7MH7223-1GX 7MH7223-1FW 7MH7223-1JT 7MH7223-1HA 7MH7223-1JS 7MH7223-1HK 7MH7223-1HL 7MH7223-1HM
		¹⁾ One MWL is required for each scale (MMI-2 requires 2 MWL). ²⁾ Select motor mounting, order code options M30 or M31. ³⁾ Available with weight type option 00 only.

Belt Weighing

Accessories

Calibration weight lifter Milltronics MWL

Dimensional drawings

MWL with MUS - STD Standard Duty Belt Scale

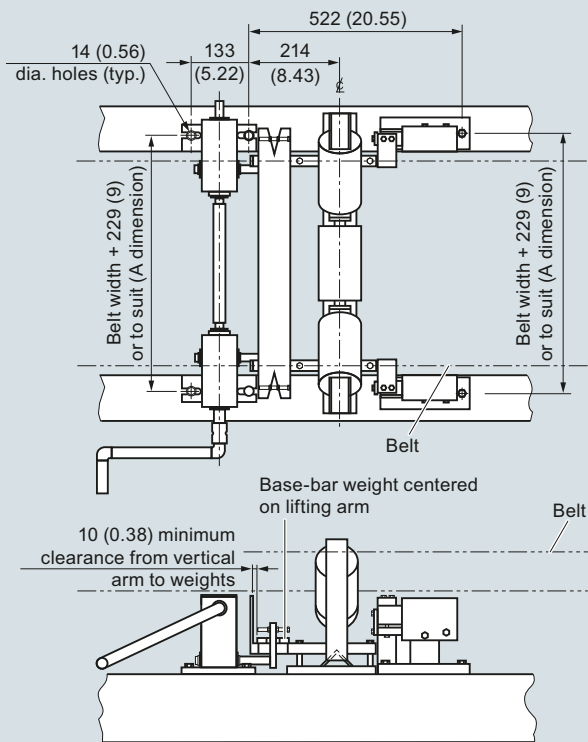

MWL with MUS - HD Heavy Duty Belt Scale

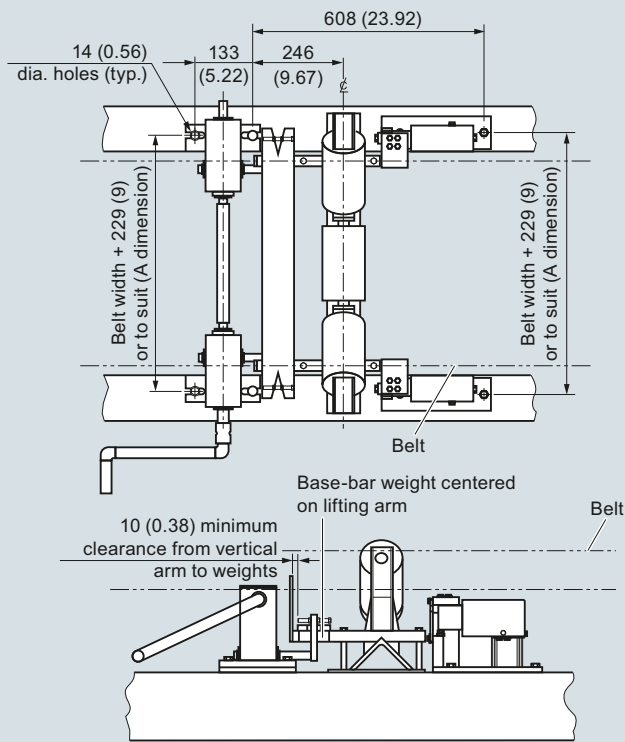

MWL, dimensions in mm (inch)

Dimensional drawings (continued)

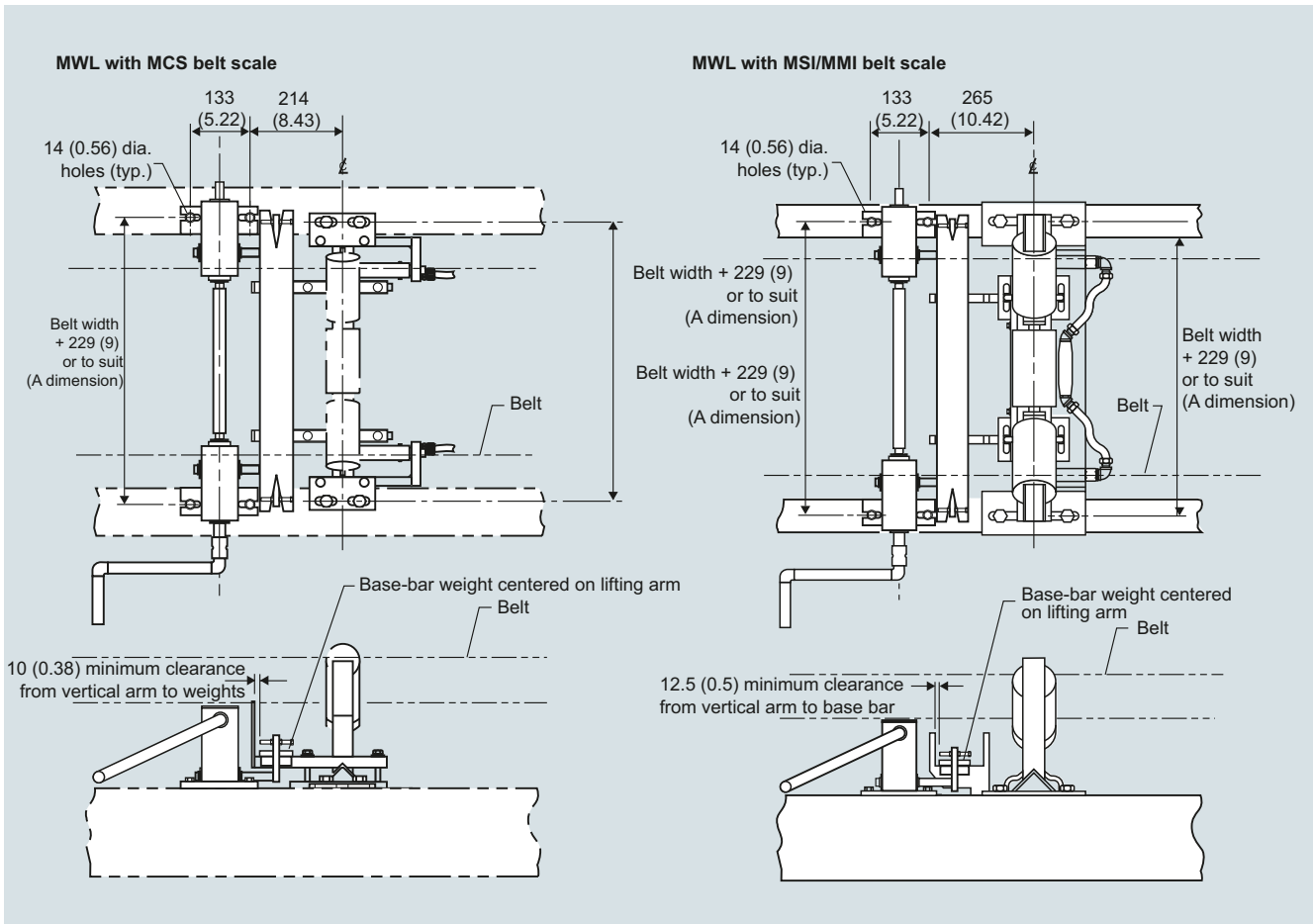

MWL, dimensions in mm (inch)

Belt Weighing

Accessories

Milltronics flat bar calibration weights

Overview

Roller test chains are used for belt scale calibration when material tests are not practical. All test chains are bushed. Minimum length is 4 feet (1.2 m).

Selection and ordering data

Article No.

Milltronics Flat bar calibration weights.

Designed for use with Milltronics belt scales.

[Click on the Article No. for the online configuration in the PIA Life Cycle Portal.](#)

Bar width, belt width and A dimension, weight

3 inch, 18 inch, A=27 inch (686 mm), 4.63 kg	1 A A
3 inch, 24 inch, A=33 inch (838 mm), 5.78 kg	1 A G
3 inch, 30 inch, A=39 inch (991 mm), 6.94 kg	1 A N
3 inch, 36 inch, A=45 inch (1 143 mm), 8.10 kg	1 A U
3 inch, 42 inch, A=51 inch (1 295 mm), 9.25 kg	1 B D
3 inch, 48 inch, A=57 inch (1 448 mm), 10.41 kg	1 B K
3 inch, 54 inch, A=63 inch (1 600 mm), 11.57 kg	1 B R
3 inch, 60 inch, A=69 inch (1 753 mm), 12.73 kg	1 C A
3 inch, 66 inch, A=75 inch (1 905 mm), 13.89 kg	1 C G
3 inch, 72 inch, A=81 inch (2 057 mm), 15.05 kg	1 C N
3 inch, 78 inch, A=87 inch (2 210 mm), 16.21 kg	1 C U
3 inch, 84 inch, A=93 inch (2 362 mm), 17.37 kg	1 D D
3 inch, 90 inch, A=99 inch (2 515 mm), 18.53 kg	1 D K
3 inch, 96 inch, A=105 inch (2 667 mm), 19.69 kg	1 D R
4 inch, 18 inch, A=27 inch (686 mm), 6.17 kg	2 A A
4 inch, 24 inch, A=33 inch (838 mm), 7.71 kg	2 A G
4 inch, 30 inch, A=39 inch (991 mm), 9.26 kg	2 A N
4 inch, 36 inch, A=45 inch (1 143 mm), 10.80 kg	2 A U
4 inch, 42 inch, A=51 inch (1 295 mm), 12.34 kg	2 B D
4 inch, 48 inch, A=57 inch (1 448 mm), 13.89 kg	2 B K
4 inch, 54 inch, A=63 inch (1 600 mm), 15.42 kg	2 B R
4 inch, 60 inch, A=69 inch (1 753 mm), 16.97 kg	2 C A
4 inch, 66 inch, A=75 inch (1 905 mm), 18.52 kg	2 C G
4 inch, 72 inch, A=81 inch (2 057 mm), 20.07 kg	2 C N
4 inch, 78 inch, A=87 inch (2 210 mm), 21.62 kg	2 C U
4 inch, 84 inch, A=93 inch (2 362 mm), 23.17 kg	2 D D
4 inch, 90 inch, A=99 inch (2 515 mm), 24.72 kg	2 D K
4 inch, 96 inch, A=105 inch (2 667 mm), 26.27 kg	2 D R

Fabrication

Standard, C5-M rated polyester painted mild steel

1