



SITRANS F

Variable area flowmeter

SITRANS FVA250

Operating Instructions

Edition

02/2013

SIEMENS

SITRANS F

Variable area flowmeter SITRANS FVA250



Operating Instructions

<u>Introduction</u>	1
<u>Safety notes</u>	2
<u>Description</u>	3
<u>Installing/Mounting</u>	4
<u>Connecting</u>	5
<u>Commissioning</u>	6
<u>Service and maintenance</u>	7
<u>Technical data</u>	8
<u>Dimensions and weight</u>	9

Legal information

Warning notice system

This manual contains notices you have to observe in order to ensure your personal safety, as well as to prevent damage to property. The notices referring to your personal safety are highlighted in the manual by a safety alert symbol, notices referring only to property damage have no safety alert symbol. These notices shown below are graded according to the degree of danger.

 DANGER
indicates that death or severe personal injury will result if proper precautions are not taken.
 WARNING
indicates that death or severe personal injury may result if proper precautions are not taken.
 CAUTION
indicates that minor personal injury can result if proper precautions are not taken.
NOTICE
indicates that property damage can result if proper precautions are not taken.

If more than one degree of danger is present, the warning notice representing the highest degree of danger will be used. A notice warning of injury to persons with a safety alert symbol may also include a warning relating to property damage.

Qualified Personnel

The product/system described in this documentation may be operated only by **personnel qualified** for the specific task in accordance with the relevant documentation, in particular its warning notices and safety instructions. Qualified personnel are those who, based on their training and experience, are capable of identifying risks and avoiding potential hazards when working with these products/systems.

Proper use of Siemens products

Note the following:

 WARNING
Siemens products may only be used for the applications described in the catalog and in the relevant technical documentation. If products and components from other manufacturers are used, these must be recommended or approved by Siemens. Proper transport, storage, installation, assembly, commissioning, operation and maintenance are required to ensure that the products operate safely and without any problems. The permissible ambient conditions must be complied with. The information in the relevant documentation must be observed.

Trademarks

All names identified by ® are registered trademarks of Siemens AG. The remaining trademarks in this publication may be trademarks whose use by third parties for their own purposes could violate the rights of the owner.

Disclaimer of Liability

We have reviewed the contents of this publication to ensure consistency with the hardware and software described. Since variance cannot be precluded entirely, we cannot guarantee full consistency. However, the information in this publication is reviewed regularly and any necessary corrections are included in subsequent editions.

Table of contents

1	Introduction.....	5
1.1	Items supplied.....	5
1.2	Scope of delivery	5
1.3	Transportation and storage.....	6
1.4	History	7
1.5	Further Information	7
2	Safety notes.....	9
2.1	Hot surfaces resulting from hot process media	9
2.2	Laws and directives	9
2.3	Installation in hazardous area	11
2.4	Certificates	14
3	Description.....	15
3.1	System components	15
3.2	Design	16
3.3	Theory of operation.....	17
4	Installing/Mounting.....	19
4.1	Installation safety precautions.....	19
4.2	Device check.....	20
4.3	Determining a location	20
4.4	Mounting the sensor	21
4.5	Damping.....	22
4.6	Retrofitting MEM transducers	24
5	Connecting	25
5.1	Wiring MEM / MEM-PPA.....	25
5.2	Electrical connection schematics	26
5.2.1	Limit switches.....	26
5.2.2	Magneto-electrical measuring transducer HART	27
5.2.3	Measuring transducer HART with 4-20 mA output, pulse output and one limit switch.....	28
5.2.4	Measuring transducer HART with 4-20 mA output and two limit switches	29
5.2.5	Magneto-electrical measuring transducer MEM-PPA.....	30
6	Commissioning	33
6.1	Analogue output (MEM)	33
6.2	Limit signal settings.....	34

6.3	Output settings	35
6.3.1	Measuring transducer HART with 4-20 mA output / pulse output / limit switches	35
6.3.2	Measuring transducer PROFIBUS	35
6.4	Configuring with HART.....	35
6.4.1	Commissioning with PDM	35
6.4.2	Basic parameter settings.....	36
6.4.3	HART parameters	37
6.5	Configuring with PROFIBUS PA	40
6.5.1	Magneto-electrical measuring transducer MEM-PPA	40
6.5.2	Acyclic communication.....	42
7	Service and maintenance	47
7.1	Maintenance.....	47
7.2	Unit cleaning	47
7.3	Recalibration	48
7.4	Unit repair.....	48
7.5	Technical support.....	49
7.6	Return procedures	49
8	Technical data	51
8.1	Classification according to pressure equipment directive (PED 97/23/EC).....	52
8.2	Pressure vs. temperature (stainless steel).....	53
8.3	Limit switches	53
8.4	MEM Transducer HART with 4-20 mA.....	54
8.5	MEM transducer HART with additional pulse output and limit switches	54
8.6	MEM transducer PROFIBUS PA	55
9	Dimensions and weight.....	57
	Index.....	61

Introduction

These instructions contain all the information you need for using the device.

The instructions are aimed at persons mechanically installing the device, connecting it electrically, configuring the parameters and commissioning it, as well as service and maintenance engineers.

Note

It is the responsibility of the customer that the instructions and directions provided in the operating instructions are read, understood, and followed by the relevant personnel before installing the device.

1.1 Items supplied

- SITRANS FVA250 variable area flowmeter
- Operating Instructions
- Calibration certificate (optional)
- Test report 2.2 (optional)
- Acceptance test (optional)
- Stainless steel TAG plate (optional)



1.2 Scope of delivery

Inspection

1. Check for mechanical damage due to possible improper handling during shipment. All claims for damage are to be made promptly to the carrier.
2. Make sure the scope of delivery and the information on the nameplate correspond to the ordering information.

Identification

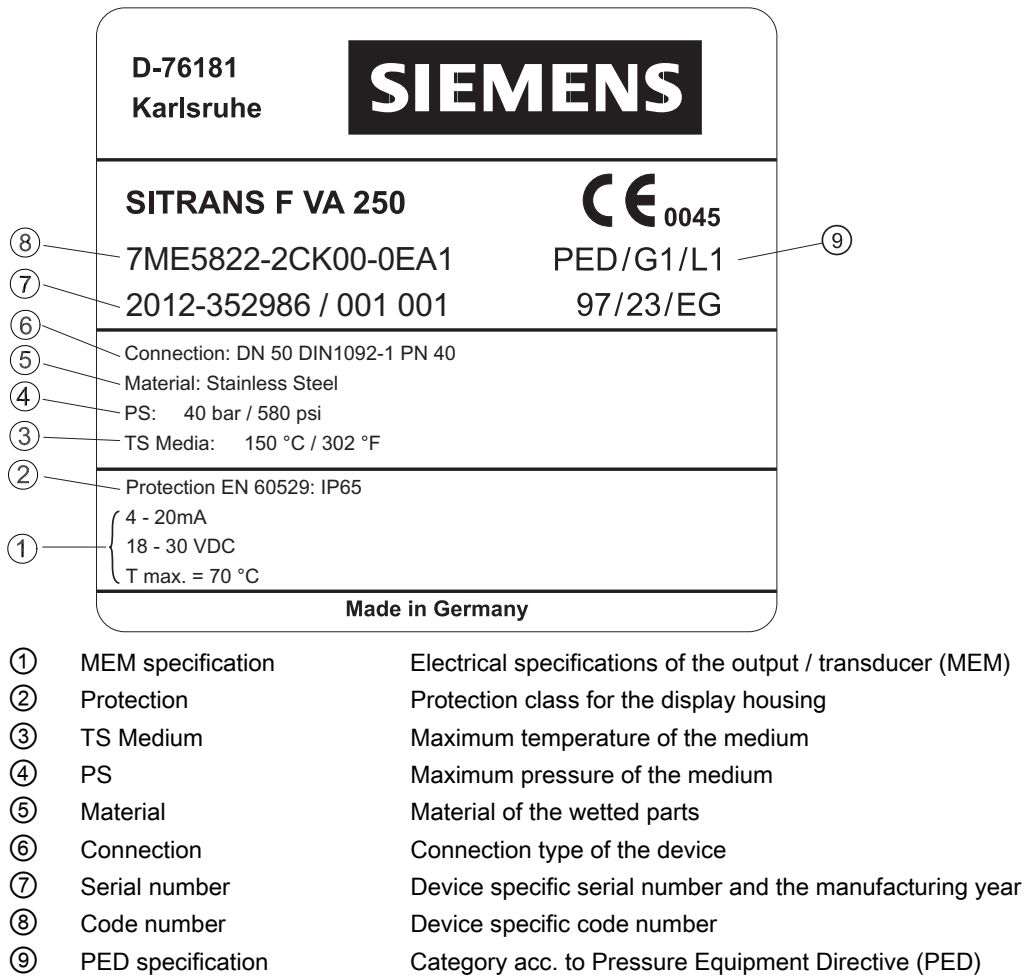

Figure 1-1 FVA250 nameplate example

1.3 Transportation and storage

To guarantee sufficient protection during transport and storage, observe the following:

- Keep the original packaging for subsequent transportation.
- Devices/replacement parts should be returned in their original packaging.
- If the original packaging is no longer available, ensure that all shipments are properly packaged to provide sufficient protection during transport. Siemens cannot assume liability for any costs associated with transportation damages.
-

 **CAUTION**
Insufficient protection during storage

The packaging only provides limited protection against moisture and infiltration.

- Provide additional packaging as necessary.

- Store the device in a dry and dust-free place.
- Keep away from direct sun and heat.
- Avoid external load to the device.
- The storage temperature range for standard devices with electrical components is -40 ... +70 °C / -40 ... +158 °F.

1.4 History

The contents of these instructions are regularly reviewed and corrections are included in subsequent editions. We welcome all suggestions for improvement.

The following table shows the most important changes in the documentation compared to each previous edition.

Edition	Remarks
02/2013	First edition Contents restructured

1.5 Further Information

Product information on the Internet

The Operating Instructions are available on the CD-ROM shipped with the device, and on the Internet on the Siemens homepage, where further information on the range of SITRANS F flowmeters may also be found:

Product information on the internet (<http://www.siemens.com/flow>)

Worldwide contact person

If you need more information or have particular problems not covered sufficiently by these Operating Instructions, get in touch with your contact person. You can find contact information for your local contact person on the Internet:

Local contact person (<http://www.automation.siemens.com/partner>)

 CAUTION
Correct, reliable operation of the product requires proper transport, storage, positioning and assembly as well as careful operation and maintenance. Only qualified personnel should install or operate this instrument.

Note

Alterations to the product, including opening or improper modifications of the product, are not permitted.

If this requirement is not observed, the CE mark and the manufacturer's warranty will expire.

2.1 Hot surfaces resulting from hot process media

 CAUTION
Hot surfaces resulting from hot process media Danger of burns resulting from surface temperatures above 70 °C (155 °F). <ul style="list-style-type: none">• Take appropriate protective measures, for example contact protection.• Make sure that protective measures do not cause the maximum permissible ambient temperature to be exceeded, see Technical data (Page 51), "Temperatures".

2.2 Laws and directives

General requirements

Installation of the equipment must comply with national regulations. For example EN 60079-14 for the European Community.

Instrument safety standards

The device has been tested at the factory, based on the safety requirements. In order to maintain this condition over the expected life of the device, the requirements described in these Operating Instructions must be observed.

NOTICE
Material compatibility Siemens Flow Instruments can provide assistance with the selection of wetted sensor parts. However, the full responsibility for the selection rests with the customer and Siemens Flow Instruments can take no responsibility for any failure due to material incompatibility. The manufacturer is not liable for any damage resulting from improper or intended use of these devices.

CE-marked equipment

The CE mark symbolizes the compliance of the device with the following directives:

- EMC-directive 2004/108/EC and 89/336/EWG
- Low voltage directive 2006/95/EC
- Pressure equipment directive (PED/DGRL) 97/23/EC
- ATEX directive 94/9/EG

Compliance to EN 13463-1 / EN 50014

In its basic design, this flow metering device is a non-electrical device without its own ignition sources. The device complies with the requirements of EN 13463-1.

The equipment is evaluated as an electrical assembly when electrical signal transducers are installed. In this case the entire equipment including the installed electrical signal transducers complies with EN 50014.

The electrical and thermal data and the special directives of the EC Type Examination Certificate with regard to the installed signal transducers must be observed and adhered to.

See also

Classification according to pressure equipment directive (PED 97/23/EC) (Page 52)

2.3 Installation in hazardous area

WARNING

Equipment used in hazardous areas must be Ex-approved and marked accordingly. It is required that the special conditions for safe use provided in the manual and in the Ex certificate are followed!

Hazardous area approvals

The device is approved for use in hazardous area zone 1 and has the following approval:

- II 2 GD c

Designation in case of installed limiting value transmitter SJ 3.5-N:

- II 2G EEx ia IIC T6-T4

Designation in case of installed magneto electrical measuring transducers HART and PROFIBUS:

- II 2G EEx ia IIC T6

WARNING

Make sure the hazardous area approval is suitable for the environment in which the device will be installed.

Intrinsically safe data

In accordance with the tables contained in the EC Type Examination Certificate PTB 99 ATEX 2219 X, the inductive sensor SJ 3.5-N must be operated within the temperature class T5 with an intrinsically safe circuit that does not exceed the maximum values of a Type 3 circuit.

Table 2- 1 Intrinsically safe circuits

Intrinsically safe circuits	Type 1	Type 2	Type 3	Type 4
Ui	16 V	16 V	16 V	16 V
Ci	50 nF	50 nF	50 nF	50 nF
Li	250 μ H	250 μ H	250 μ H	250 μ H
li	25 mA	25 mA	52 mA	76 mA
Pi [mW]	34 mW	64 mW	169 mW	242 mW

 WARNING
<p>With intrinsically safe circuits, use only certified sensors appropriate for the transmitter.</p> <p>If a non-conforming supply unit is used, the "fail-safe" type of protection will no longer be effective and the approval certification will be invalid.</p>

Temperature specifications for Ex use

Table 2- 2 Maximum ambient temperature (Ta)

Temperature class	Type 1	Type 2	Type 3	Type 4
T6	73 °C	66 °C	45 °C	30 °C
T5	88 °C	81 °C	60 °C	45 °C
T4	100 °C	100 °C	89 °C	74 °C

Note

Temperature specification

For further temperature specification, see Technical data (Page 51), "Temperatures".

Ambient temperature factors

The impact of the process media temperature on the installed signal transducers must be taken into account.

For this purpose the temperature rise of the maximum process media temperature in relation to the maximum ambient temperature and the appropriate factor defined in the following table must be taken into consideration.

Table 2- 3 Ambient temperature factors

Nominal width	Factor (standard model)	Factor (advanced display)
DN15 and DN25	0.2	0.07
DN40 and DN50	0.25	0.085
DN80 and DN100	0.3	0.1

Example 1

Example of calculation of the ambient temperature at limiting value transmitter (limit switch SJ 3.5-N) for sizes DN 15 and DN 25.

- Max. ambient temperature: $T_{amb} = 40 \text{ °C}$
- Max. process media temperature: $T_m = 120 \text{ °C}$

- Factor for heat input: $F = 0.2$
- Temperature class: T4
- T_e = excess temperature
- T_a = ambient temperature at limiting value transmitter (limit switch SJ 3.5-N)

$$T_e = T_m - T_{amb} = 120^{\circ}\text{C} - 40^{\circ}\text{C} = 80^{\circ}\text{C}$$

$$T_a = (T_e * F) + T_{amb} = (80^{\circ}\text{C} * 0,2) + 40^{\circ}\text{C} = 56^{\circ}\text{C}$$

Figure 2-1 Calculation of ambient temperature at limiting value transmitter (limit switch SJ 3.5-N)

Example 2

Example of the calculation of the max. process media temperature in relation to the max. ambient temperature for the installed sensor type at widths for sizes DN 15 and DN 25

- $T_a = 70^{\circ}\text{C}$
- $T_{amb} = 60^{\circ}\text{C}$
- $F = 0.2$

$$T_m = \left(\frac{T_a - T_{amb}}{F} \right) + T_{amb} = \left(\frac{70^{\circ}\text{C} - 60^{\circ}\text{C}}{0.2} \right) + 60^{\circ}\text{C} = 110^{\circ}\text{C}$$

Figure 2-2 Calculation of max. process media temperature

Special conditions for safe use

The maximum surface temperature of the measuring substance is decisive as the equipment does not exhibit its own energy sources that could lead to a rise in temperature.

Regular cleaning is essential when the equipment is employed in dust-explosive zones in order to prevent sedimentation exceeding the thickness of 5 mm.

It is required that:

- Electrical connections are in accordance with EN 60079-14 (Installing Electrical Systems in Explosion Hazardous Areas).
- The protective cover over the power supply is properly installed. For intrinsically safe circuits the connection area can be opened.
- Appropriate cable connectors are used for the output circuits:
 - Intrinsically safe: blue
 - Non-intrinsically safe: black
- Sensor and transmitter are connected to the potential equalization.
For intrinsically safe output circuits potential equalization must be maintained along the entire connection path.
- Sensor insulation thickness is max. 100 mm (only insulated sensors).

- EN 50281-1-2 is considered for installation in areas with combustible dust.
- When protective earth (PE) is connected, no potential difference between the protective earth (PE) and the potential equalization (PA) can exist, even during a fault condition.

 WARNING
"Flameproof enclosure" type of protection Only open devices with protectiontype "Flameproof enclosure" in hazardous areas when the power to the device is turned off, otherwise there is a risk of explosion.

 WARNING
Laying of cables Cable for use in zone 1 and 2 or 21 and 22 must satisfy the requirements for having a proof voltage < 500 V AC applied between the conductor/ground, conductor/shield and shield/ground. Connect the devices that are operated in hazardous areas as per the stipulations applicable in the country of operation, e.g. for Ex "d" and "nA", permanent cables must be laid.

2.4 Certificates

Certificates are posted on the Internet and on the documentation CD-ROM shipped with the device.

See also

Certificates on the Internet (<http://www.siemens.com/processinstrumentation/certificates>)

Description

The SITRANS FVA250 is suitable for multipurpose measuring of fluids and gases in closed piping systems.

The robust design also permits application under harsh conditions.

Different flange connections, liners and rotameter materials meet the requirements in the pharmaceutical and chemical industry.

3.1 System components

- SITRANS FVA250 fitting
- Float (optional with damping piston)
- Gas damping (optional)
- Indicator unit (incl. bearing unit, scale, scale pointer)
- MEM transducer with HART / PROFIBUS protocol (optional)
- Limiting value transmitter(s) (optional)



Figure 3-1 Variable area flowmeter

Magneto-electrical measurement transducers (MEM)

SITRANS FVA250 is optionally available with magneto-electrical measurement transducers for configuration with HART (MEM) or with PROFIBUS PA (MEM-PPA).

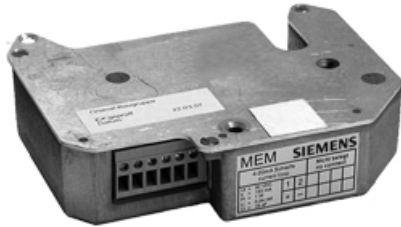

Figure 3-2 Magneto-electrical measurement transducer (MEM)

3.2 Design

SITRANS FVA250 is an all-metal variable area flowmeter with a standard length of 250 mm (9.84 inch). The momentary flowrate is indicated in volume or mass per time unit. The measured value is indicated directly on the scale.

The equipment can be supplied with accessory electrical components and touch-sensitive switches for process monitoring and control.

Features

- Standard model can be supplied at short notice
- Robust all-metal fitting with shock-proof housing
- Applicable for the measurement of aggressive and combustible materials
- Applicable for high pressures and temperatures
- Product and percentage scale
- Optionally supplied with heating and cooling jackets fitted
- Contamination-resistant design

MEM transducers

The measuring transducers MEM / MEM-PPA are installed in the flowmeter FVA250. In this manner the range of volume flow measurement is covered.

The measuring transducers MEM / MEM-PPA are designed for installation in a housing that is at least compliant with enclosure rating IP20.

3.3 Theory of operation

The FVA250 operates according to the principle of flotation. The flowing measuring substance raises the conical float in the measuring ring. In this way the annular gap widens until an equilibrium between the buoyancy of the measuring substance and the weight of the float is achieved. The height achieved by the float is directly proportional to the flowrate. The movement of the float is transmitted via a magnet to a subsequent magnet in the display part outside the measuring pipe.

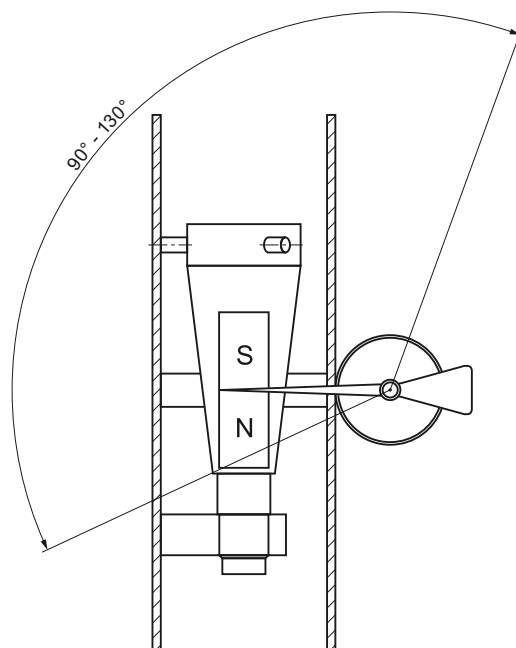

Figure 3-3 Measuring cone / scale angle

MEM transducers

The setting of the float is transmitted to the pointer axis by means of a magnetic system on the pointer axis. The measuring transducers MEM / MEM-PPA measures the field of a magnet mounted to the pointer axis. The scale, which is generally non-linear, is linearized with a maximum of 16 interpolation points in the process.

- The MEM transducer (HART) generates a resulting output current 4...20 mA. The earth magnetic field and homogeneous external magnetic fields, if not too high, are more or less compensated by the differential measurement.
- The MEM transducer (HART) provides limit switches and a pulse output. The pulses are displayed at binary output N1. It must be observed that the maximum pulse output rate amounts to approximately 10 Hz. The pulse width is approximately 50 ms.
- The MEM-PPA transducer (PROFIBUS PA) generates a digitalized measured value.

Description

3.3 Theory of operation

Installing/Mounting

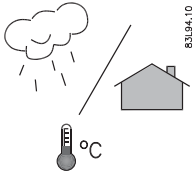

83194-10

SITRANS F flowmeters with minimum IP65/NEMA 4X enclosure rating are suitable for indoor and outdoor installations.

- Make sure that pressure and temperature specifications indicated on the device nameplate / label will not be exceeded.

! WARNING

Installation in hazardous location

Special requirements apply to the location and interconnection of sensor and transmitter. See "Installation in hazardous area" (Page 11)

! CAUTION

Aggressive atmospheres

Damage to device through penetration of aggressive vapors.

- Ensure that the device is suitable for the application.

4.1 Installation safety precautions

! WARNING

High pressure hazard

In applications with working pressures/media that can be dangerous to people, surroundings, equipment or others in case of pipe fracture, we recommend that special precautions such as special placement, shielding or installation of a pressure guard or a safety valve are taken when the sensor is mounted.

4.2 Device check

Prior to installation check the functionality of the device:

- Remove the transport protection from the fitting.
- Verify the free mobility of the float.
 - The float must slide smoothly in the pipe without canting or deadlocking.
 - The pointer must smoothly follow the movement of the float.
 - In the idle state (no flow) the pointer must be at the marked reference point (first line on the scale).
 - At the end position of the float the pointer must be above the final value of the scale.

4.3 Determining a location

Ensure that there is sufficient clearance to magnet-influencing parts, such as for example solenoid valves and ferromagnetic components, e.g. steel brackets/structures.

Clearance between adjacently mounted devices

Observe at least 300 mm (11.8") as the lateral clearance between 2 adjacently mounted instruments.

The instruments can be mounted staggered by the length of one instrument at reduced clearance.

Clearance to influencing steel parts

The lateral clearance to influencing steel parts must constitute at least 200 mm. In case of doubt the influence can be tested by moving the instrument up and down approximately 200 mm (7.87") at a selected clearance and verifying whether the position of the pointer in the display changes.

Inlet / outlet conditions

- Inlet and outlet pluggings in front of and behind the instrument are usually unnecessary in the case of linear flow profile of the medium.
- Avoid installation of unilaterally constricting fittings in front of the instrument.
- As a rule, interference-free inlet and outlet tracks are not required. In the case of highly asymmetric flow profiles, however, additional measures (e.g. inlet tracks, flow rectifiers) could be expedient for the attainment of measuring accuracy.
If this is absolutely necessary, at least the length of the instrument = 250 mm (9.84") should be designed as the inlet track.
- The nominal width of the pipe to be connected must correspond to the nominal width of the measuring instrument.
- For gases, valves must be installed in the outlet of the measuring device.

4.4 Mounting the sensor

Before mounting

- Verify that accessories such as spring stop, gas/fluid damping are still correctly seated in the flange.
- Check that the installation clearance between the flanges of the pipe correspond to the fitting dimension of the instrument and additionally 2 gaskets.

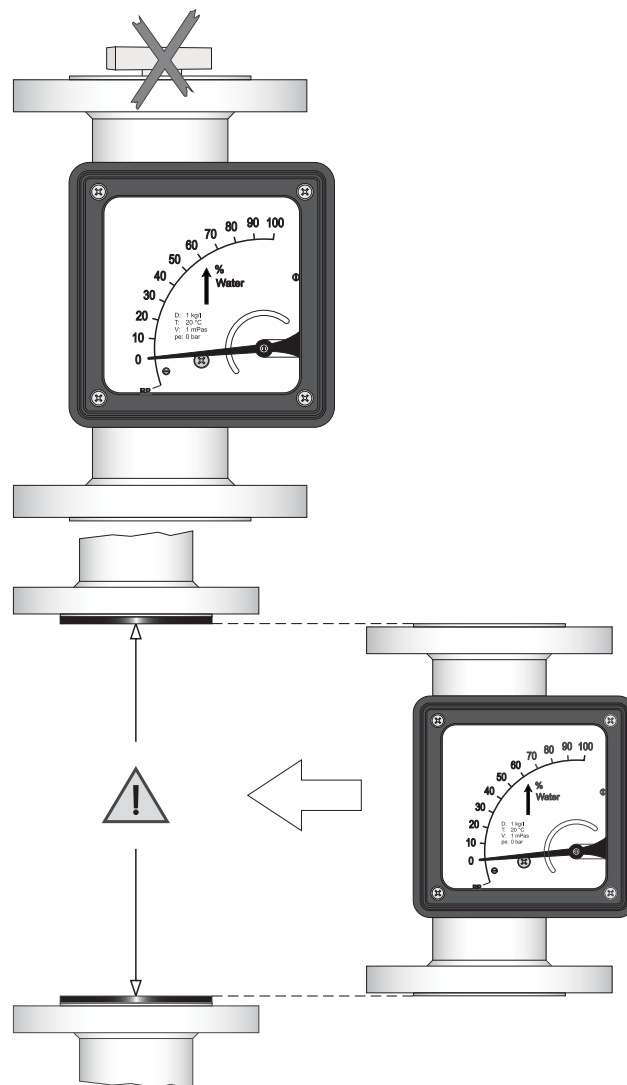

Mounting the device

- Install the device vertically.
- Ensure that the values displayed on the scale are visible and readable.
- Ensure adequate space for a potential upgrading of the instrument.

- Align the flanges in order to achieve an installation free from strain.
- Use mounting screws and gaskets of the prescribed dimensions. The gaskets must be appropriate for the operating pressure, the temperature and the process media.

 **CAUTION**

PTFE-lined devices

For PTFE-lined instruments, use gaskets where the inner and outer dimensions conform with the raised face of the device.

- Tighten the screws crosswise so that the process connections are sealed. The tightening torque for the screws must be adhered to especially in the case of PTFE-lined devices. The flange screws for PTFE-lined fittings may only be tightened with the following maximum torques (VDI/VDE Guideline 3513):
 - DN 15 to 25 (½" to 1"): 14 Nm
 - DN 50 (2"): 25 Nm
 - DN 80 (3"): 35 Nm
 - DN 100 (4"): 42 Nm.
- Ensure that the pipe has been mounted securely enough to exclude any vibration or oscillation.
- Do not use steel mounting brackets on the instrument!

Gas applications

Pay particular attention to the positioning of the valve when gas is to be measured. If the instrument is absolutely calibrated for a pressure exceeding 1.013 bar, the valve is usually installed in the outlet of the flowmeter.

In order to prevent compression oscillation during gas measurements, a throttle must be arranged immediately behind the measuring instrument. In order to avoid erroneous measurements, the arrangement must be selected to ensure that the pressure prevailing in the measuring instrument corresponds to the reference pressure of the calibration.

4.5 Damping

Variable area flowmeter damping is recommended:

- In general during the measurement of gas
- If air bubbles in the medium cannot be avoided
- If shock pressure predominates in the pipes, arising through a delay in the flow, e.g. due to rapid throttling or shut-off
- If turbulence, pulsations or any other type of instability in the variable area flowmeter could lead to vibration
- If the flow pressure cannot be built up slowly
- If vibrations in the line cannot be avoided

Installation and dismantling of the cone/float/damper/spring stop

The instrument must be dismantled from the pipe before the float can be removed. After dismantling, clamp the instrument in a horizontal position, ensuring that the fitting is not damaged in the process. The dismantling procedure depends on the variable area flowmeter model.

Model with measuring ring:

- Prevent the float (1) from torsion by fixing the upper guide bracket (2) by using a suitable tool.
- Remove from below the screw in the instrument from the guide bracket and then remove the guide bracket.
- Remove the self-locking nut (3) which fixes the lower guide bracket (4) and take the guide bracket out of the instrument.
- Take the float out of the measuring unit upwards.
- Insert the new float into the instrument from the top. While doing so carefully put the bottom end of the float through the measuring ring.
- Insert the lower guide bracket at the bottom end of the float and fix it with the self-locking nut.

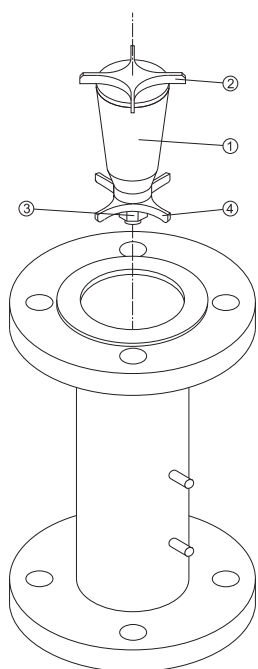

Figure 4-1 Replacing floats

- ① Float
- ② Upper guide bracket
- ③ Self-locking nut
- ④ Lower guide bracket

Model with cone:

Replacing floats for devices with cone (standard measuring ranges up to 5-50 l/h (gases: 0.15 – 1.5 m³/h) cannot be executed by the customer. For this purpose the device has to be returned to the manufacturer. For details refer to "Return procedures" (Page 49).

NOTICE
Use of unsuitable tools Danger of device damage through use of unsuitable tools <ul style="list-style-type: none">• Avoid damaging the float/measuring ring and cone.

Important

After the replacement of the float a recalibration of the flowmeter is highly recommended, otherwise the measurement accuracy cannot be ensured.

4.6 Retrofitting MEM transducers

Retrofitting of a MEM / MEM-PPA in a fitting that has been installed is only conditionally possible.

If the fitting is calibrated with a pointer axis that does not yet bear a measuring magnet, the scale must be recalibrated. The reason for this measure is the reaction of the supplementary measuring magnet on the float magnet.

Connecting

5.1 Wiring MEM / MEM-PPA

To connect the magneto-electrical measuring transducer proceed as follows:

1. Remove display cover.
2. Insert cable set via cable gland.
3. Guide signal leads under MEM / MEM-PPA from cable gland to terminal block of magneto-electrical measuring transducer.
4. Connect the device according to applicable electrical schematic:
 - Magneto-electrical measuring transducer HART (Page 27)
 - Measuring transducer HART with 4-20 mA output, pulse output and one limit switch (Page 28)
 - Measuring transducer HART with 4-20 mA output and two limit switches (Page 29)
 - Magneto-electrical measuring transducer MEM-PPA (Page 30)
5. Tighten cable gland.
6. Remount display cover.
7. Seal tightly.

 **CAUTION**

Non-observance of polarity

Observe the specified polarity requirements. Non-observance of polarity may damage the device.

5.2 Electrical connection schematics

5.2.1 Limit switches

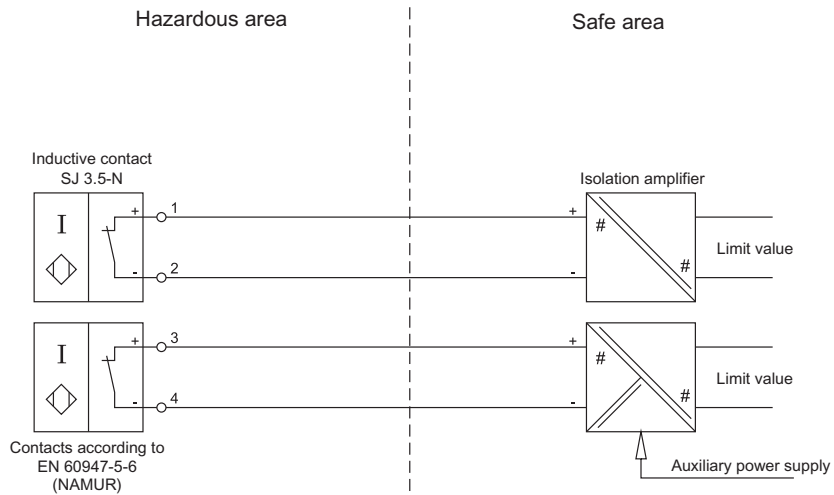

Figure 5-1 Terminal diagram for inductive limit switches

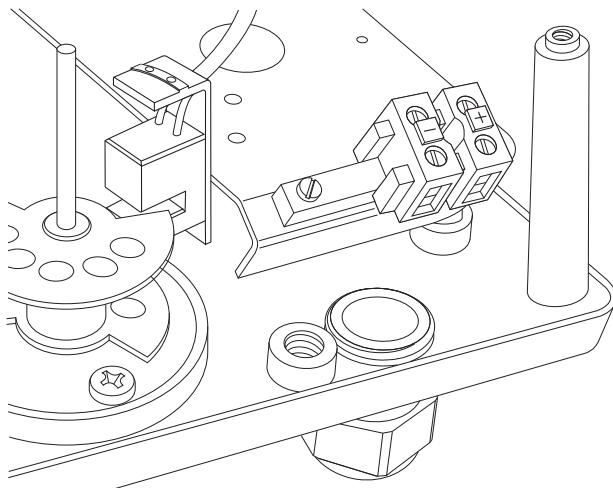

Figure 5-2 Terminals - one limit switch

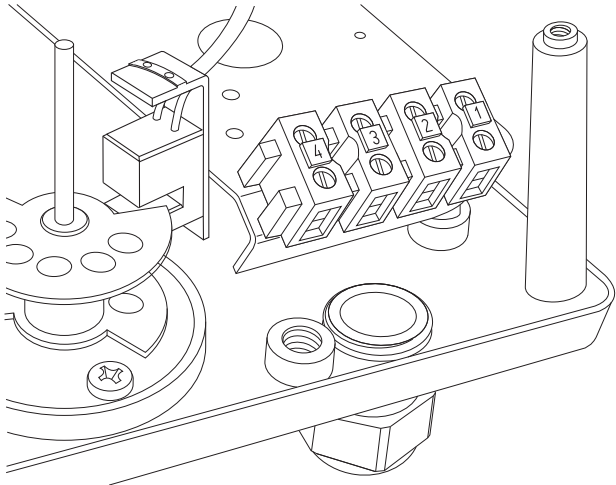

Figure 5-3 Terminals - two limit switches

5.2.2 Magneto-electrical measuring transducer HART

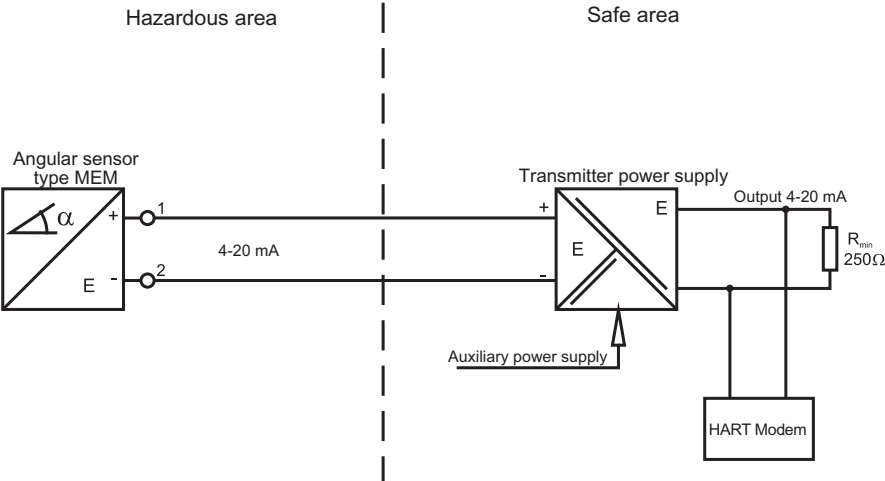

Figure 5-4 Terminal diagram for magneto-electrical measuring transducer HART

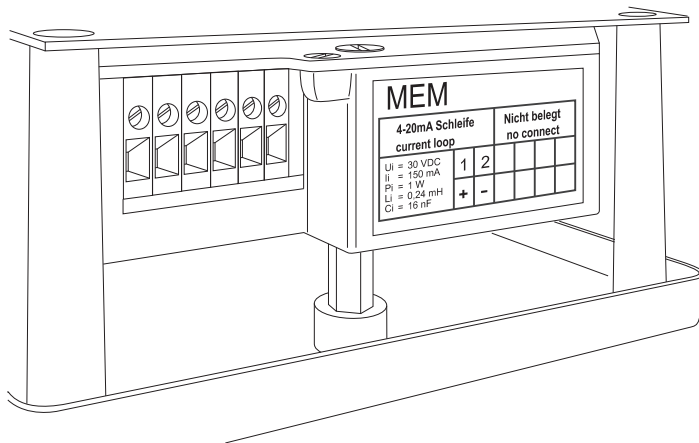

Figure 5-5 Terminals - transducer MEM with 4-20 mA output

Table 5- 1 Supply current data (EEx ia IIC T6)

L_i	240 μ H	U_i	30 V
C_i	16 nF	I_i	150 mA
T_a	70°C	P_i	1000 mW

5.2.3 Measuring transducer HART with 4-20 mA output, pulse output and one limit switch

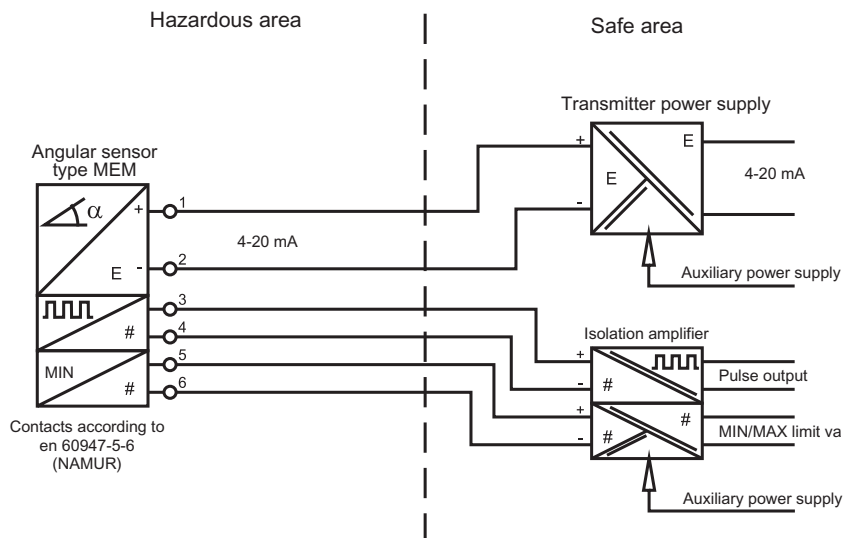

Figure 5-6 Terminal diagram for measuring transducer HART with 4-20 mA output, limit switch and pulse output

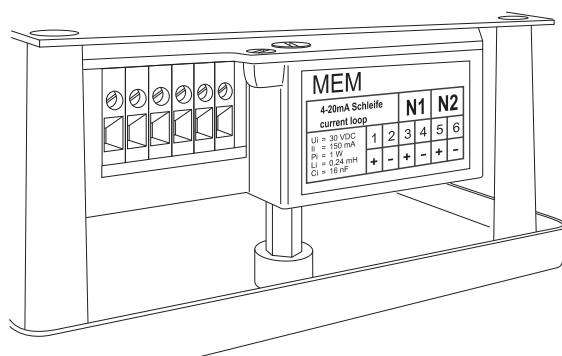

Figure 5-7 Terminals - transducer MEM with 4-20mA output and binary outputs

Table 5- 2 Supply current data (EEx ia IIC T6)

L_i	240 μ H	U_i	30 V
C_i	16 nF	I_i	150 mA
T_a	70°C	P_i	1000 mW

Table 5- 3 Binary outputs (EEx ia IIC T6)

L_i	4 μ H	U_i	30 V
C_i	16 nF	I_i	20 mA
T_a	70°C	P_i	100 mW

5.2.4 Measuring transducer HART with 4-20 mA output and two limit switches

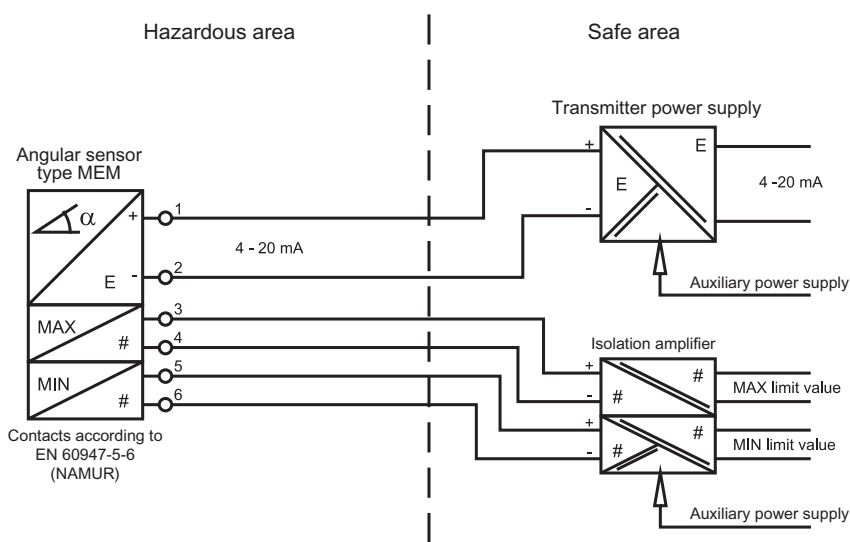

Figure 5-8 Terminal diagram for measuring transducer HART with 4–20 mA output and two limit contacts

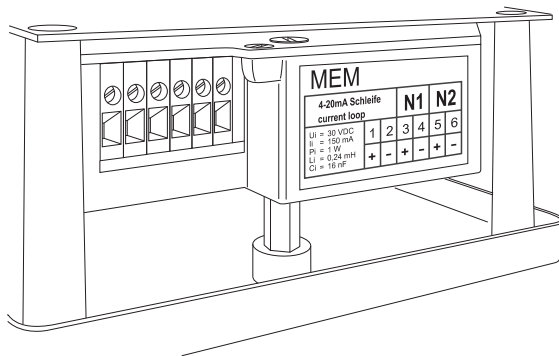

Figure 5-9 Terminals - transducer MEM with 4-20 mA output and binary outputs

Table 5-4 Supply current data (EEx ia IIC T6)

L _i	240 μH	U _i	30 V
C _i	16 nF	I _i	150 mA
T _a	70°C	P _i	1000 mW

Table 5-5 Binary outputs (EEx ia IIC T6)

L _i	4 μH	U _i	30 V
C _i	16 nF	I _i	20 mA
T _a	70°C	P _i	100 mW

5.2.5 Magneto-electrical measuring transducer MEM-PPA

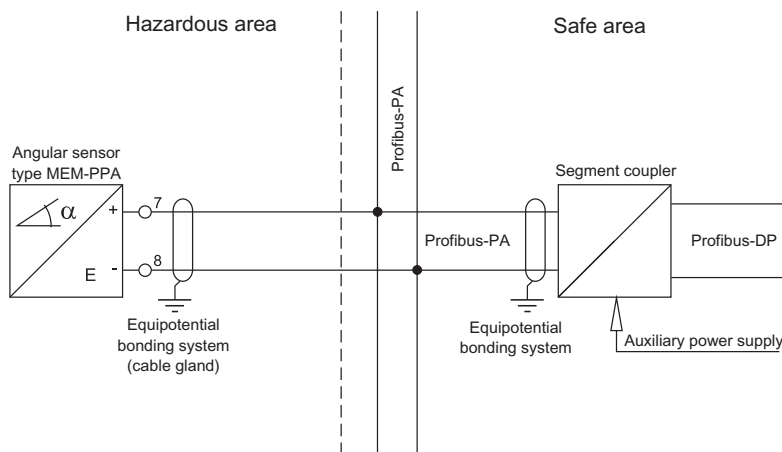

Figure 5-10 Terminal diagram for measuring transducer MEM-PPA

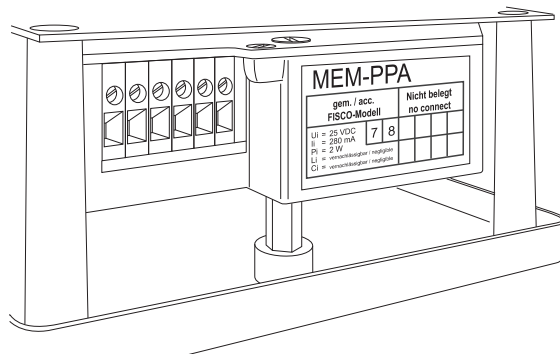

Figure 5-11 Terminals - transducer MEM-PPA

Table 5- 6 Supply current data (EEx ia IIC T6)

L_i	10 μ H	U_i	25 V
C_i	5 nF	I_i	280 mA
T_a	70°C	P_i	2000 mW

Commissioning

When starting up the device, the following points must be observed:

- Ensure that the actual operation conditions (pressure, temperature) do not exceed the limits which are given on the nameplate of the device
- Avoid float impacts!
Therefore it is recommended to start up with a closed shut-off valve and open it slowly. Particularly the use of solenoid valves is not recommended.
- When measuring liquids, the pipes must be vent slowly to prevent shock pressure due to gas bubbles.
- When measuring gases, the pressure must be increased slowly in order to prevent high shock pressure.
- During the start-up of new systems, residual materials are conveyed in the medium and could adhere to the float. In this case we recommend cleaning the instrument after a relatively short period of operation.
- When operating the flowmeter at low flowrates, the device has to start-up with a high flowrate to allow the float to level out. This will ensure measurements within the specified accuracy class.

6.1 Analogue output (MEM)

The magneto-electrical measuring transducer (MEM) is completely factory-set when it is delivered to the customer.

After applying the supply voltage to the device, the current output will be 3.5 mA to 4 mA for a few seconds. After that a current corresponding to the pointer deflection will flow.

Note

Correct current output

Due to the influence of the float magnet, the MEM transmitter will only output the correct current if the pointer position is caused by the float. Turning the pointer manually will cause incorrect values, but it is suitable for testing the unit.

6.2 Limit signal settings

Limit switches (inductive contact)

The limit switches can be set over the entire measuring range by varying the position of the limit pointers.

CAUTION

Unless otherwise desired by the customer, the factory set value for the switching point is for version with one limit switch about 40% of URV (Upper Range Value) and for devices with two limit switches about 20%/80% of URV.

To set the limit switches at the desired position, observe the following steps:

1. Loosen the two fixing screws ② before moving the pointer ①.
2. Move the pointer to the desired position.
3. Tighten the screws to fix the pointer.

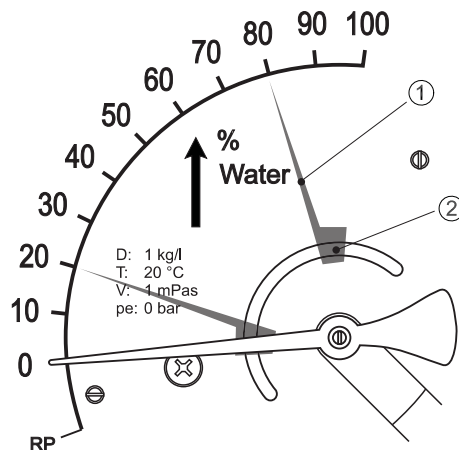

Figure 6-1 Adjustment of the switching point (limit switch)

CAUTION

The applied limit switches SJ 3.5 N are normally closed contacts according to NAMUR recommendation NE21. The desired switching function of the limit switch must be realized by the relay contact of the external isolation amplifier (changeover contact).

6.3 Output settings

6.3.1 Measuring transducer HART with 4-20 mA output / pulse output / limit switches

The magneto-electrical measuring transducer has already been calibrated with regard to the scale values by the manufacturer when it is delivered to the customer.

The HART version can only be supplied with a 2-conductor 4-20 mA connection signal output. The signal output and the limits can be configured using a HART modem with the configuration program "SIMATIC PDM" from Siemens.

6.3.2 Measuring transducer PROFIBUS

The PROFIBUS PA is designed with an interface to provide a digital communication electric circuit in compliance with the FISCO model.

The configuration tool for the signal output is "SIMATIC PDM" from Siemens.

6.4 Configuring with HART

6.4.1 Commissioning with PDM

SIMATIC PDM (Process Device Manager) is a software package for configuring, parameterizing, commissioning and maintaining field devices (e.g. transducers).

Among other features, SIMATIC PDM contains a simple process for monitoring process values, interrupts and status/diagnosis signals of a field device.

Note

For instructions on installation and operation of SIMATIC PDM, refer to the SIMATIC PDM Getting Started (included in the documentation package that comes with PDM)

Setting up the connection to the field unit

For the creation of the communication between the field unit and the PC a corresponding project must first be defined in the SIMATIC Manager.

The structure of the communication network is defined here. This consists of the field unit with integrated HART interface and a PC with a connected HART modem.

Adding the device to the Network

1. Add PC to SIMATIC communication network:

- Select "File" → "New".
 - Right-click on "Net" and select "Insert New Object" → "PC".
Your PC is now added to the Communication Net.
 - Right-click on "PC" and select "SIMATIC PDM" → "Define current PC" in order to allocate the PC.
2. Set up the communication parameters for SIMATIC communication network:
 - Right-click on "PC" and select "Insert New Object" → "COM interface".
 - Right-click on "COM interface" and select: "Object properties" → "Connection".
 - Enter the number of the COM Port.
 3. Add HART modem to SIMATIC communication network:
 - Right-click on "Net" and select "Insert New Object" → "HART modem".
 - Right-click on "HART modem" and select: "Object properties" → "Connection".
 - Select the Master Type "Secondary".
 4. Add the field unit to the SIMATIC communication network:
 - Right-click on "HART modem" and select: "Insert new object" → "HART device".
 - Type in a name for the field unit, e.g. FVA250.
 - Make sure that the field unit address is set to 0.
 - Click on "Assign" and assign the device to MEM (Sensors→Flow→Variable Area→SIEMENS→MEM) and click "OK".

6.4.2 Basic parameter settings

Read all parameters

Before any parameterization is carried out all parameters must be read from the device into the offline table of SIMATIC PDM. This is necessary because the offline table merely contains default data.

1. Open the PDM device driver.
2. Select "Device" → "Upload to PC/PG".
3. Select "Execute even if the device TAG does not match the project data TAG" and click "OK" to read all parameters to the offline table.
After closing the dialog all loaded parameters should show "Loaded" in the status of the PDM table.

Setting basic parameters

Parameters that can be set by the user are categorically highlighted in white – whereas the remaining attributes are protected and highlighted in gray.

1. Configure basic parameters.

2. Select: "Device->Download to device".
3. Select "Execute even if the device TAG does not match the project data TAG" and click "OK".

6.4.3 HART parameters

The available parameters are grouped into the following blocks:

Identification

General information on devices that enable the clear definition of the device is deposited in this parameter block.

The following parameters can be deposited:

- TAG
- Description
- Date
- Message
- Works number

Basic settings

The time response of the MEM is set in this parameter block.

- Damping
A time constant within the range of 0 to 60 seconds can be selected via these parameters. On expiry of this time the measured value reaches 63.7% of the final condition with an abrupt change of the input signal.

Input

All parameters that are involved in the acceptance of the measured value in the MEM are included in this block.

- **Unit**
The unit of the measured variable is defined via this parameter. The following units are available:
 - m³/h, m³/min, m³/s
 - l/h, l/min, l/s
 - USgal/h, USgal/min, USgal/s
 - IMPgal/h, IMPgal /min, IMPgal /s
 - kg/h
 - t/h
 - g/h

Note

Change of unit

In case of alteration of the unit no conversion of the measured value or the upper range value is conducted.

- **MIN/MAX**
These two parameters define the maximum and the minimum limits of the relative flowrate.
The falling short of or exceeding of MIN/MAX can be transmitted as an alarm at power output (see description of self-test) as well as via the binary outputs (see description of outputs)
- **Final value**
This parameter (in HART known as "URV") serves the adaptation of the power output to the measuring range (20 mA = 100%).
The initial value of the measuring range (in HART known as "LRV" (lower range value)) is not supported by the MEM and is reset to zero.
- **Leak flow volume**
This parameter is a percent value and determines a minimum flowrate value (in relation to the final value). Below the leak flow volume, the measured value is reset to zero.

Outputs

This block comprises all parameters that define the behavior of the current output and the binary outputs.

- Power output – power in case of alarm
An alarm status of the MEM (see description of self-test) can optionally be displayed at the current output. The possible current settings are:
 - >20.5 mA (typically 21.6 mA)
 - <3.8 mA (typically 3.6 mA)
 - unused
- NAMUR switch – function
The binary outputs N1 and N2 (NAMUR switch) are constructed as optocouplers with downstream transistor and comply with the industrial standard EN 60947-6-6:2000. The functions of the outputs are controlled by the microprocessor and may comprise the following functions:

N1	N2
MAX	MIN
Pulse output	MIN
Pulse output	MAX
Pulse output	MIN/MAX

Note

Parameters MIN and MAX

The parameters MIN and MAX are the limits of relative flow defined in the parameter block Input.

- NAMUR switch – activated state
The activated status of the NAMUR switches N1 and N2 is set via this parameter. The options are:
 - closed
 - open

Note

Activated state

The set active status also applies to N1 if this is configured as a pulse output.

Totalizer (pulse output)

Both the totalizer and the pulse output measures volume and measuring units.

The dimension unit of the totalizer pursues that of the flow rate (e.g. if the flow rate unit is l/h, the totalizer will measure in liters).

Pulses are optionally displayed at binary output N1. It must be observed that the maximum impulse rate amounts to approx. 10 Hz. The pulse width is approx. 50 ms.

- **Totalizer**

The totalizer function of the MEM can be switched ON or OFF via this parameter.

The totalizer value is saved in the EEPROM when the instrument is switched off. The totalizer can be reset via a HART command.

Self test

The MEM possesses various self-test functions for continuous monitoring of the current measuring values, which may be used to trigger an alarm in case of error.

- **Self-test mask**

The MEM self-test possesses the following function range, whereby each control function can be individually switched ON and OFF:

- Q > 103% (rel. flowrate > 103%)
- Q <> Sensor limits (rel. flowrate outside the sensor limit)
- Sensors too hot/too cold (temperature in device too high/too low)
- A-B unreasonable (sensor signals implausible)
- Meter overflow
- MIN/MAX-limit (shortfalling MIN or exceeding MAX)

The incidence of a self-test error is signaled under HART in status and, if necessary, transmitted as an alarm on the current output.

6.5 Configuring with PROFIBUS PA

6.5.1 Magneto-electrical measuring transducer MEM-PPA

PROFIBUS- PA- interface

PROFIBUS- PA divides the parameters that are important for configuring the device in the system into function blocks. These parameters can only be accessed acyclically. The function and assignment of these blocks were defined by the PROFIBUS User Organization (PNO) in the "Profile for process control devices Rev. 2.0, Class B".

The transmitter MEM-PPA exclusively uses Profile 3 area flowmeters, because Profile 2 does not apply to area flowmeters.

The "Physical Block" includes information about the device (e.g. type, profile and manufacturer).

The "Transducer Block" contains transmitter-specific parameters (e.g. calibration factor, zero point and nominal size).

The analog input "Function Block" contains the parameters for forming the output value (e.g. limit values, measuring range and time constant). The output value of this block (OUT) can also be accessed cyclically.

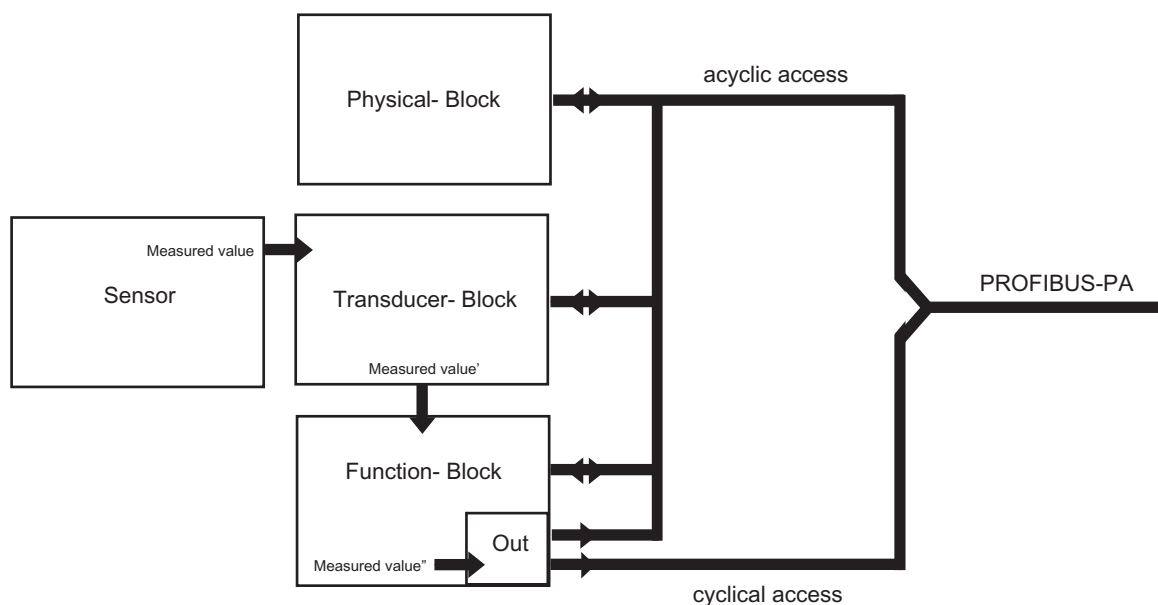

Figure 6-2 Block model of the MEM with PROFIBUS-PA

GSD File

This file is needed for the integration of the device into the PROFIBUS- PA network and will be copied into the subdirectory defined by the programmable controller software.

The GSD file can be downloaded from the Siemens homepage (Support-Center).

Name of file: PA139700.GSD

Device address

The device address is used for selecting the device in the system.

This address may only be assigned once. Note that devices with identical addresses will collide during bus access.

The device address can only be set via the bus. When the device is shipped from the factory, the preset address is 126.

Before commissioning the system, every new device must be assigned a new, unassigned address (<126).

Cyclic communication

The master can cyclically read out the "OUT" measured value from the MEM-PPA transmitter. The measured value is represented as a 32-bit floating-point number in accordance with IEEE-754; the corresponding status is represented as an 8-bit word. The unit of the measured value can be selected (see Acyclic communication/unit of measured value).

Assigning a meaning to the status word

The meaning of the status messages has been defined by the PROFIBUS User Organization (PNO).

The device reports the following states:

Hex	Meaning	Quality of the measuring value	Condition
0x8A	Exceeding HI-LIM	Good	Measured value exceeding warning value
0x89	Shortfalling LO-LIM	Good	Measured value is falling below warning value
0x8E	Exceeding HI-HI-LIM	Good	Measured value exceeding alarm value
0x8D	Shortfalling LO-LO-LIM	Good	Measured value falling below alarm value.
0x52	Exceeding upper	Uncertain, measured value is inaccurate	Sensor limit exceeding limit value
0x51	Falling below lower	Uncertain, measured value is inaccurate	Sensor limit falling below limit value

6.5.2 Acyclic communication**Parameters of the Transducer Block****Set Zero**

The zero point can be changed manually. The zero point parameter is set in the unit of flow/level/density and is continuously subtracted from the uncorrected measured value.

Calibration factor

The measured value is multiplied by the calibration factor. This factor is 1 when the device is shipped from the factory. The following formula is used:

$$\text{Flow rate} = (\text{uncorr. flow rate} - \text{zero point}) \cdot \text{calibration factor}$$

Low-flow cutoff

The unit of the low-flow cutoff is identical to the unit of the flow rate. At level/density applications this parameter should be set to zero. If the flow drops below the low-flow cutoff, the measured value will be set to zero. Hysteresis is 3%, with an unilateral effect.

Flow direction

The flow direction can be indicated by a sign. If the sign is negative, reverse flow turns into forward flow.

Device mode

The MEM-PPA measures unidirectional (only forward flow).

Filter type (Information field)

Normal, strong.

Nominal size

The nominal size is factory-set as appropriate for the corresponding flowmeter sensor. The unit is inch. The maximum allowable diameter setting is 4".

The upper and the lower sensor limit

This parameter defines the upper range value. The unit is identical to flowrate/level/density unit. If the upper range value limits are exceeded, an alarm will be generated.

Self-test

The MEM-PPA self-test can be activated (=1) or switched off (=0). The existence of an error is displayed in the OUT state.

Units of measured value

The measured value of the flow rate/level/density can be acyclically read from the transducer block. The following units are available:

m³/h

m³/min

l/h

l/min

USGal/h

USGal/min

IMPGal/h

IMPGal/min

t/h

kg/h

g/h

Changing the unit does not automatically adjust the measuring range value!

Parameters of the Analogous Input Function Block**Filter time constant**

Between 0 to 60 seconds, are used for damping the measured value. Damping is carried out during measured-value acquisition.

Simulation

Instead of the measured value and the status from the Transducer Block, a simulation value and a simulation status can be defined. Simulation can be switched on or off (1 = ON, 0 = OFF).

 **CAUTION**

The simulation must be manually switched off. The simulation is terminated when the device is switched off and on.

PVScale

Based on the measured value of the flow rate (see Transducer Block), the relative value is calculated first. PVScale parameter (consisting of 100% = URV, 0% = LRV, unit of the measured value (PVScale))

$$(Q \text{ in } \%) = \frac{(\text{meas. value } Q) - PVScale_{0\%}}{PVScale_{100\%} - PVScale_{0\%}}$$

The measured value unit must be identical to the unit of the Transducer Block; measured value, URV and LRV e.g. in l/h

In this block parameters that relate to the recording of the measuring value of the MEM-PPA are summarized.

OUTScale

In the next step the absolute value of the output is calculated on the relative value. OUTScale parameter (consisting of 100% = URV = end value, 0% = LRV = beginning value, output unit):

$$OUT = (Q \text{ in } \%) \cdot (OUTScale_{100\%} - OUTScale_{0\%}) + OUTScale_{0\%}$$

The units of the Parameter block OUTScale are identical to the Transducer Block/Measuring unit.

HI-LIM / HI-ALM (upper warning limit)

If the limit is exceeded, a warning is issued.

HI-HI- LIM / HI-HI-ALM (upper alarm limit)

If the limit is exceeded, an alarm is issued.

LO-LIM / LO-ALM (lower warning limit)

If the measured value falls below this limit, a warning is issued.

LO-LO- LIM / LO-LO-ALM (lower alarm limit)

If the measured value falls below this limit, an alarm is issued.

Hysteresis

The hysteresis of the limit values has a one-sided effect.

OUT

Here the value "OUT" can be read acyclically.

Factory Reset (acyclic communication)

The "factory reset" command resets several parameters to their default values.

- Device address: 126
- Filter time constant: 3 seconds
- Low-flow cutoff: 0
- Reset of TAG, Descriptor, Date

A factory reset causes a reset of the parameter blocks PVScale, OUTScale and Limit values to the basic unit m³/h.

Maintenance

The MEM-PPA is maintenance-free. In case of a malfunction the MEM-PPA can be replaced. A malfunction has, for example, occurred when the output current supplied by the device differs considerably from the expected value (e.g. difference cannot be explained with a temperature drift).

If there is a justified doubt about the operation of the device, the device must be returned to the manufacturer. The device must not be repaired by the user.

Service and maintenance

7.1 Maintenance

The device is maintenance-free, however, a periodic inspection according pertinent directives and regulations must be carried out.

An inspection can include check of:

- Ambient conditions
- Seal integrity of the process connections, cable entries, and cover screws
- Reliability of power supply, lightning protection, and grounds

Instrument cleaning

During the setting into operation of new systems, residual materials are conveyed in the medium and could adhere to the variable area meter. In this case we recommend cleaning the instrument after a short period of operation. In particular ferromagnetic substances such as weld beads could lead to the shut-down of the equipment. A magnet filter (accessory) should be mounted in front of the instrument if such fragments cannot be avoided in routine operation.

7.2 Unit cleaning

Depending on the measuring substances, contamination, abrasion or chemical reactions could affect the measuring orifice and the float and hence have an impact on the measuring accuracy. In this case the instrument should be dismantled and cleaned with suitable agents including the rotameter.

 CAUTION
--

Aggressive cleaning agents

Do not damage the device mechanically by hard objects or by aggressive cleaning agents.

 WARNING
--

Device corrosion

If attacks are detected on the measuring orifice or the float, they must be recalibrated or replaced.

7.3 Recalibration

Observe the following points:

- In instruments with installed electrical equipment, the removal of the display hood will lead to constraint in the EMC protection.
- Before you dismount an instrument, ensure that the pipeline is free from process media and pressure and has cooled down.
- Fittings that are coated on the inside can be cleaned carefully following disassembly using a brush and appropriate cleaning agents. The rotameter should be carefully cleaned to remove coating.

Switching point adjustment

The switching points of the limiting value transmitters are adjustable.

- Remove the display hood, loosen the contact point pointers on the scale and re-set.
- Tighten the screws of the contact point pointers after adjustment.
- Replace the display hood and fix tightly.

The parameterization of the MEM may be carried out using "Commissioning with PDM" (Page 35).

Check cylinders and gas fluid dampers for contamination (see "Dismounting/Installation of dampers" (Page 22)).

On conclusion of the maintenance and cleaning work the instruments must be subjected to a function control before being put back into operation.

7.3 Recalibration

Siemens A/S Flow Instruments offers to recalibrate the sensor. The following calibration is offered as standard:

- Standard matched pair calibration

Note

For recalibration the memory unit must always be returned with the sensor.

7.4 Unit repair

NOTICE
Repair and service must be carried out by Siemens authorized personnel only.

Note

Siemens defines flow sensors as non-repairable products.

7.5 Technical support

If you have any technical questions about the device described in these Operating Instructions and do not find the right answers, you can contact Customer Support:

- Via the Internet using the **Support Request**:

Local contact

person <http://support.automation.siemens.com/WW/llisapi.dll?func=cslib.csinfo&lang=en&objid=16604318&caller=view>

<http://support.automation.siemens.com/WW/llisapi.dll?func=cslib.csinfo&lang=en&objid=16604318&caller=view>

- Via Phone:
 - Europe: +49 (0)911 895 7222
 - America: +1 423 262 5710
 - Asia-Pacific: +86 10 6475 7575

Further information about our technical support is available on the Internet at Support request (<http://www.siemens.com/automation/support-request>)

Service & Support on the Internet

In addition to our documentation, we offer a comprehensive knowledge base online on the Internet at:

Service and support (<http://www.siemens.com/automation/service&support>)

There you will find:

- The latest product information, FAQs, downloads, tips and tricks.
- Our newsletter, providing you with the latest information about your products.
- Our bulletin board, where users and specialists share their knowledge worldwide.
- You can find your local contact partner for Industry Automation and Drives Technologies in our partner database.
- Information about field service, repairs, spare parts and lots more under "Services."

Additional Support

Please contact your local Siemens representative and offices if you have additional questions about the device.

Find your local contact partner at: <http://www.automation.siemens.com/partner>

7.6 Return procedures

Enclose the delivery note, the cover note for return delivery and the declaration of decontamination form on the outside of the package in a well-fastened clear document pouch.

Required forms

- **Delivery Note**
- **Cover Note for Return Delivery** with the following information

Cover note

(<http://support.automation.siemens.com/WW/llisapi.dll?func=cslib.csinfo&lang=en&objid=16604370&caller=view>)

- product (ordering number)
- number of devices or spare parts returned
- reason for the return

- **Declaration of Decontamination**

Declaration of Decontamination

(http://www.automation.siemens.com/w1/efiles/feldg/files/Service/declaration_of_decontamination_en.pdf)

With this declaration you certify *that the returned products/spare parts have been carefully cleaned and are free from any residues.*

If the device has been operated together with toxic, caustic, flammable or water-damaging products, clean the device before return by rinsing or neutralizing. Ensure that all cavities are free from dangerous substances. Then, double-check the device to ensure the cleaning is completed.

We shall not service a device or spare part unless the declaration of decontamination confirms proper decontamination of the device or spare part. Shipments without a declaration of decontamination shall be cleaned professionally at your expense before further proceeding.

You can find the forms on the Internet and on the CD delivered with the device.

Technical data

Table 8- 1 General data

Range of application	Flow measurement of liquids and gases
Measuring principle	Flotation / Float measuring
Orientation	Vertical - flow direction from bottom to top

Table 8- 2 Measuring accuracy

Directive	VDI / VDE 3513, sheet 2 (qG = 50%)
Liquids	G 1.6 (add. 0.2%* of URV for MEM / MEM-PPA)
Gases	G 2.5 (add. 0.2%* of URV for MEM / MEM-PPA)
Reproducibility	0.5% of URV (add. 0.1% of URV for MEM / MEM-PPA)

* Additional error in the event of temperature deviations from the reference conditions of the calibration process.

Table 8- 3 Materials

		Type CF-S	Type EF-H	Type FF-P
Wetted parts		Stainless steel	Hastelloy®	PTFE
Flange	≤ DN 25 (1")	Stainless steel*	Hastelloy®**	Stainless steel*
	> DN 25 (1")		Hastelloy® stainless*	
Fitting	≤ DN 25 (1")	Stainless steel*	Hastelloy®**	Stainless steel with PTFE liner
	> DN 25 (1")		Hastelloy® stainless*	
Float / Guide bracket		Stainless steel*	Hastelloy®**	PTFE
Display unit		Aluminium (optional stainless steel) with safety glass pane		

* Stainless steel (1.4404 / 1.4571)

** Hastelloy 24610

Table 8- 4 Operating conditions - all devices

Temperature		Type CF-S	Type EF-H	Type FF-P
Max. medium temp. TS		-20 ... +200 °C (-4 ... +392 °F) -80 ... +300 °C (-112 ... +572 °F)		-20 ... +125 °C (-4 ... +257 °F)
Pressure (see chapter 8.2)				
		Type CF-S	Type EF-H	Type FF-P
Max. medium pressure PS	DN 15 - DN 100	PN 160 (optional up to 400 bar)		
	½" - 4"	580 psi (optional up to 5800 psi)		

8.1 Classification according to pressure equipment directive (PED 97/23/EC)

Min. operating pressure	> 2 x pressure loss (see measuring ranges)
Climate classification	Weatherproof and/or non-heated locations Class C in accordance with DIN IEC 654 Section 1
Protection class (DIN EN 60529)	
Display unit	Aluminum: IP65 Stainless steel: IP66

Table 8- 5 Temperatures

Device version	Ambient temperature*	Storage temperature
Without electrical components	-40 ... +80 °C (-40 ... +176 °F)	-40 ... +80 °C (-40 ... +176 °F)
With limit switch (es)	-40 ... +65 °C (-40 ... +149 °F)	-40 ... +65 °C (-40 ... +149 °F)
With 4 ... 20 mA output	-40 ... +70 °C (-40 ... +158 °F)	-40 ... +70 °C (-40 ... +158 °F)

*IMPORTANT!

Note

Hazardous areas

For applications in hazardous areas it is mandatory to observe the temperature class of the type examination certificate (protection type).

For devices used in hazardous areas, additional safety notes apply; see "Installation in hazardous area" (Page 11).

8.1 Classification according to pressure equipment directive (PED 97/23/EC)

Process connection		Permissible media	Category
EN 1092-1	ANSI B16.5		
DN 15	½"	Gases and fluids of fluid group 1	Article 3.3
DN 20	¾"	Gases and fluids of fluid group 1	Article 3.3
DN 25	1"	Gases and fluids of fluid group 1	Article 3.3
DN 32	1¼"	Gases and fluids of fluid group 1	III
DN 40	1½"	Gases and fluids of fluid group 1	III
DN 50	2"	Gases and fluids of fluid group 1	III
DN 65	2½"	Gases and fluids of fluid group 1	III
DN 80	3"	Gases and fluids of fluid group 1	III
DN 100	4"	Gases and fluids of fluid group 1	III

8.2 Pressure vs. temperature (stainless steel)

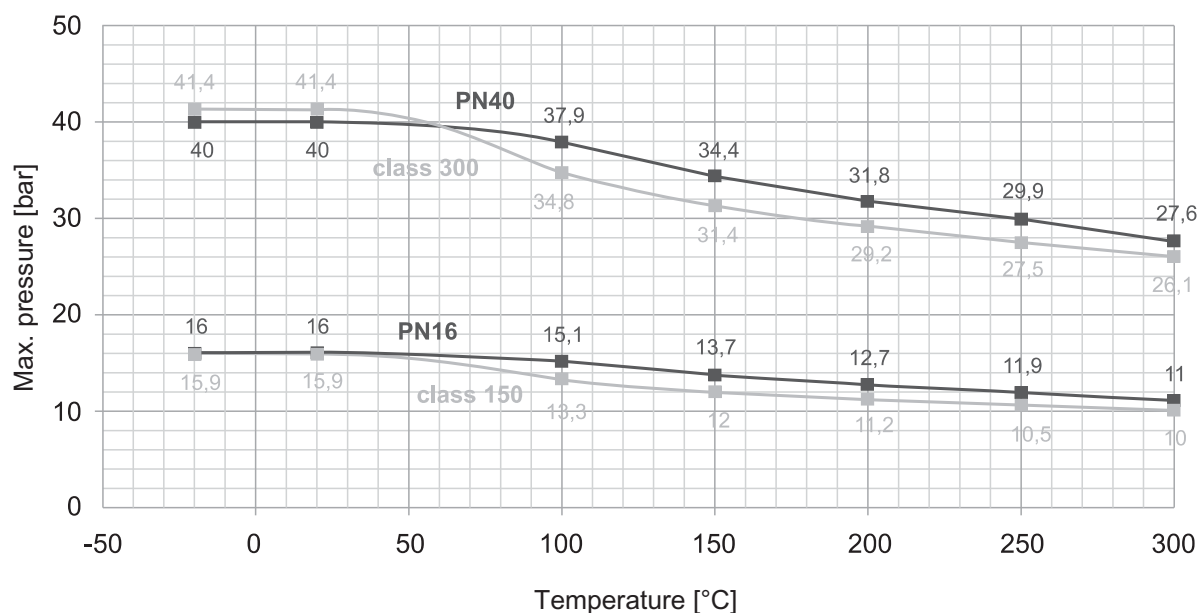

8.3 Limit switches

Switching principle	Inductive contact, single contact and twin contact, NAMUR NC
Connection	M20x1.5
Auxiliary power supply	8 V DC, Ri approx. 1 kOhm
Self-inductance	250 µH
Self-capacitance	50 nF
Ambient temperature	
<ul style="list-style-type: none"> When used in non-hazardous locations Explosion protection EC-Type Examination Certificate for Directive 94/9/EC 	-40 ... +65 °C (-40 ... +149 °F) II 2G EEx ia IIC T6 PTB 99 ATEX 2219 X
Isolation (2 contacts)	Galvanically isolated
Terminal connection	2.5 mm ²
Limit switch	SJ 3.5-N
Supply voltage	5 ... 25 V DC

8.4 MEM Transducer HART with 4-20 mA

Electric remote transmitter, signal output HART	
Connection	2-wire
Auxiliary power supply	14 ... 30 V DC
Output	4 ... 20 mA
Ambient temperature • When used in non-hazardous locations	-40 ... +70 °C (-40 ... +158 °F)
Explosion protection	II 2G EEx ia IIC T6
EC-Type Examination Certificate for Directive 94/9/EG	BVS 07 ATEX E 033
Measuring accuracy • In the supporting structure • Influence of power supply • Influence of load (0.2 ... 680Ω) • Influence of ambient temperature	< ±0.2 % of URV < ±0.1 % of measured value < ±0.1 % of measured value < ±0.5 % of URV/10°K
Reproducibility	Typically < 0.1% of URV
Resolution	Typically 0.05 % of URV
Conformity Electromagnetic compatibility (EMC)	<ul style="list-style-type: none"> • EN 61000-6-2;1999 • EN 50081-1 • EN 55011:1998+A1:1999 Group1, Class B • NAMUR NE21
Electrical connection terminals	2.5 mm ²
Load	Max. load R _B is dependent on power supply: $R_B = \frac{UB - 14V}{22mA}$ R _B < 250 Ω on application of the HART protocol

8.5 MEM transducer HART with additional pulse output and limit switches

Binary outputs	
Switching principle	NAMUR switch in accordance with EN 60947-6-6:2000
Number	2
Control state • open • closed	Typically 0.4 mA Typically 4.0 mA

Function	Limit signal transducer or pulse output
Explosion protection	II 2G EEX ia IIC T6 (-40 ... +70 °C [-40 ... +158 °F]) Ui = 30 V DC li = 20 mA Pi = 100 mW Li = 4 µH Ci = 16 nF BVS 07 ATEX E 033

8.6 MEM transducer PROFIBUS PA

Electric remote transmitter, signal output PROFIBUS PA	
Connection	2-wire
Auxiliary power supply	10 ... 25 V DC
Basic current	< 16.5 mA
Fault current	< 18 mA
Transfer rate	31.25 kBaud
Ambient temperature	
• When used in non-hazardous locations	-40 ... +70 °C (-40 ... +158 °F)
Explosion protection	II 2G EEx ia IIC T6
EC-Type Examination Certificate for Directive 94/9/EC	BVS 07 ATEX E033
Accuracy	
• In the interpolation points	< ±0.2% of URV
• Influence of power supply	<0.1 % of measured value
• Influence of ambient temperature	< ±0.5 % of URV/10°K
Reproducibility	Typically < 0.1 % of URV
Resolution	Typically 0.05 % of URV
Conformity	
Electromagnetic compatibility (EMC)	<ul style="list-style-type: none"> • EN 61000-6-2:1999 • EN 50081-1 • EN 55011:1998+A1:1999 Group1, Class B <ul style="list-style-type: none"> • NAMUR NE21
Safety data	EEX ia IIC T6 (-40 ... +70 °C [-40 ... + 158 °F]) Ui = 25 V DC li = 280 mA Pi = 2 W Li < 10 µH Ci < 5 nF BVS 07 ATEX E033

Dimensions and weight

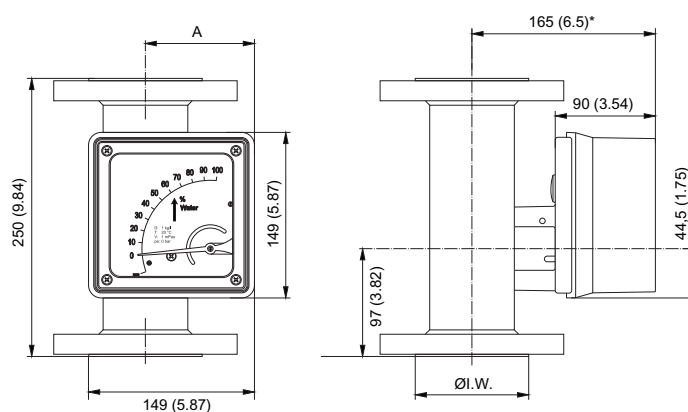

Figure 9-1 SITRANS FVA250, Standard version (aluminum display housing)

Table 9- 1 Dimensions in mm (inch), SITRANS FVA250 standard version

DN	PN	I. W.	A	Weight [kg (lbs)]
15 (½")	40 (150 lbs)	26 (1.02)	74 (2.91)	3.0 (6.6)
20 (¾")	40 (150 lbs)	26 (1.02)	74 (2.91)	3.0 (6.6)
25 (1")	40 (150 lbs)	32 (1.26)	77 (3.03)	4.2 (9.3)
32 (1 ¼")	40 (150 lbs)	32 (1.26)	77 (3.03)	5.2 (11.5)
40 (1 ½")	40 (150 lbs)	46 (1.81)	88 (3.46)	6.0 (13.2)
50 (2")	40 (150 lbs)	70 (2.76)	97 (3.82)	7.5 (16.5)
65 (2 ½")	16 (150 lbs)	70 (2.76)	97 (3.82)	8.5 (18.7)
80 (3")	16 (150 lbs)	102 (4.02)	113 (4.45)	13 (28.7)
100 (4")	16 (150 lbs)	125 (4.92)	126 (4.96)	18 (39.7)

* +100 mm with displaced display

Heating jacket version

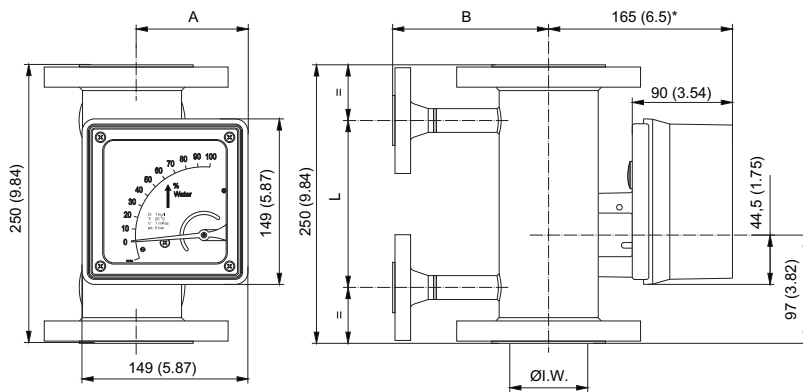

Figure 9-2 SITRANS FVA250, Heating jacket version

Table 9- 2 Dimensions in mm (inch), heating jacket version

DN	B flange	S	Weight [kg (lbs)]
15 (½")	110 (4.33)	150 (5.91)	4.7 (10.4)
20 (¾")	110 (4.33)	150 (5.91)	4.7 (10.4)
25 (1")	110 (4.33)	150 (5.91)	5.9 (13.0)
32 (1 ¼")	110 (4.33)	150 (5.91)	6.9 (15.2)
40 (1 ½")	130 (5.12)	150 (5.91)	7.8 (17.2)
50 (2")	140 (5.51)	150 (5.91)	9.6 (21.1)
65 (2 ½")	140 (5.51)	150 (5.91)	11.0 (24.2)
80 (3")	160 (6.3)	150 (5.91)	16.0 (35.2)
100 (4")	175 (6.89)	120 (4.72)	22.0 (48.4)

* + 100 mm with displaced display

Stainless steel version

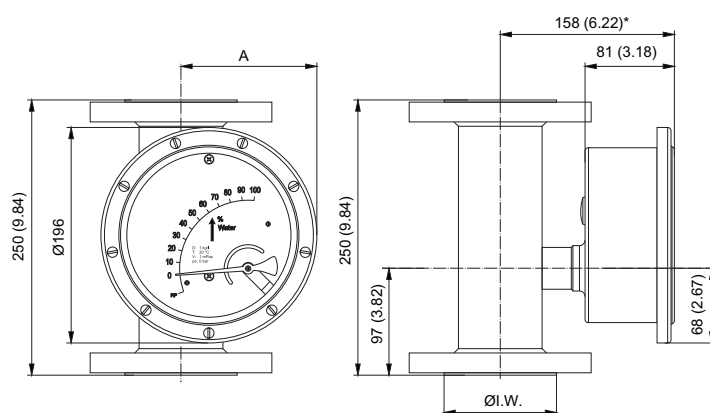

Figure 9-3 SITRANS FVA250, Stainless steel version (stainless steel display housing)

Table 9- 3 Dimensions in mm (inch), stainless steel version

DN	PN	I. W.	A	Weight [kg (lbs)]
15 (½")	40 (150 lbs)	26 (1.02)	103 (4.06)	3.1 (6.8)
20 (¾")	40 (150 lbs)	26 (1.02)	103 (4.06)	3.1 (6.8)
25 (1")	40 (150 lbs)	32 (1.26)	105 (4.13)	4.3 (9.5)
32 (1 ¼")	40 (150 lbs)	32 (1.26)	105 (4.13)	5.3 (11.7)
40 (1 ½")	40 (150 lbs)	46 (1.81)	115 (4.53)	6.1 (13.4)
50 (2")	40 (150 lbs)	70 (2.76)	129 (5.08)	7.6 (16.7)
65 (2 ½")	16 (150 lbs)	70 (2.76)	129 (5.08)	8.6 (18.9)
80 (3")	16 (150 lbs)	102 (4.02)	145 (5.71)	13.1 (28.9)
100 (4")	16 (150 lbs)	125 (4.92)	158 (6.22)	18.1 (39.9)

* +100 mm with displaced display

Index

A

Applications, 15

C

Commissioning
 with PDM, 35
Communication network, 35
Compliance, 9
Contact person, 7
Customer Support Hotline, 49

D

Damping, 22
Decontamination, 49
Device check, 20
Dimensions
 Heating jacket version, 58
 Stainless steel version, 59
Document History, 7

F

Features, 16

H

Hazardous area
 Approvals, 11
 Special conditions, 13
 Temperature specifications, 12
Hotline, 49

I

Installation
 Indoor/outdoor, 19
 Safety instructions, 19
Internet
 Contact person, 7, 49
 Flowdocumentation, 7

Support, 49
Intrinsically safe circuits, 11
Introduction, 5
Items supplied, 5

L

Laws and directives, 9

M

Maintenance, 47
Material compatibility, 10

P

PDM
 Commissioning, 35
Pressure
 Safety instructions, 19

R

Recalibration, 48
Repair, 48
Return procedures, 49

S

Safety, 9
 Instrument safety standards, 10
 Sensor installation, 19
Service, 48, 49
Support, 49

T

Temperature specifications, 12
Theory of operation, 17

For more information

www.siemens.com/flow

Siemens A/S
Flow Instruments
Nordborgvej 81
DK-6430 Nordborg

Subject to change without prior notice
Order No.: A5E03821131
Lit. No.: A5E03821131-01
© Siemens AG 02.2013

www.siemens.com/processautomation