

SIEMENS

Ingenuity for life

GM-SG and GM-SG-AR

Metal-clad switchgear
5 kV - 15 kV

usa.siemens.com/mvswitchgear



SIEMENS

SIEMENS

WARNING
HIGH VOLTAGE
KEEP OUT



This selection and application guide for the types GM-SG and GM-SG-AR 5 kV-15 kV metal-clad switchgear presents the features, benefits, ratings and dimensions of the equipment.

Siemens' experience gained in over 80 years of supplying metal-clad switchgear in the U.S. has been captured in the type GM-SG-AR design. The objective has been to incorporate features designed to provide safety, simplifying both operation and maintenance, and minimizing installation cost.

Table of contents

| | |
|------------------------------------|---------|
| Overview | 04 – 08 |
| Construction | 09 – 18 |
| Accessories | 19 – 20 |
| Protective relays | 21 |
| Vacuum circuit breakers | 22 – 29 |
| Generator vacuum circuit breakers | 30 – 34 |
| Technical data | 35 – 43 |
| Stacking versatility | 44 – 45 |
| Side views | 46 – 47 |
| Anchoring and section arrangements | 48 – 55 |

Overview

Medium-voltage, air-insulated, metal-clad switchgear with options for arc-resistance, Sm@rtGear™ solution, and Siemens Integrated Electrical-Racking System (SIERS).

Introduction

Siemens' experience gained in over 80 years of supplying metal-clad switchgear in the U.S. has been captured in the type GM-SG family of switchgear. The objective has been to incorporate features designed to provide safety, simplifying both operation and maintenance, and minimizing installation cost.

The Siemens type GM-SG family of metal-clad switchgear assemblies, with horizontal drawout type GMSG vacuum circuit breakers, takes advantage of the latest developments in vacuum interrupter technology. Up to two circuit breakers can be stacked in a single vertical section, allowing significant space savings.

The equipment meets or exceeds the latest standards of ANSI, IEEE and NEMA.

Type GM-SG switchgear is designed for use in industrial plants, commercial buildings, electric utility systems, cogeneration installations and other electrical systems.

It is commonly used for protection and switching of transformers, motors, generators, capacitors, buses, distribution feeder lines and, in general, for protection of any medium-voltage power circuit.

The type GM-SG family includes both conventional type GM-SG non-arc-resistant switchgear, and type GM-SG-AR arc-resistant switchgear, both presented in Figure 1: Types GM-SG and GM-SG-AR medium-voltage switchgear lineups.

The type GM-SG-AR arc-resistant switchgear has been tested to ANSI/IEEE C37.20.7 requirements for accessibility type 2B. This construction is intended to provide an additional degree of protection to personnel in close proximity to the equipment in the event of an internal arcing fault.

The switchgear structure and the drawout vacuum circuit breaker are an integrated design, with dielectric, thermal and interruption integrity built directly into the basic design, not as an afterthought.

Figure 1: Types GM-SG and GM-SG-AR medium-voltage switchgear lineups



| Designation | Enclosure type |
|-------------|--|
| GM-SG | Non-arc-resistant, indoor |
| OGM-SG | Non-arc-resistant, non-walk-in outdoor |
| SGM-SG | Non-arc-resistant, single-aisle outdoor, Shelter-Clad |
| GM-SG-AR | Arc-resistant indoor |
| SGM-SG-AR | Arc-resistant, single-aisle outdoor, Shelter-Clad |
| S+GM-SG | Non-arc-resistant, single-aisle outdoor, Shelter-Clad+ |
| S+GM-SG-AR | Arc-resistant, single-aisle outdoor, Shelter-Clad+ |

Table 1: Type GM-SG family designation

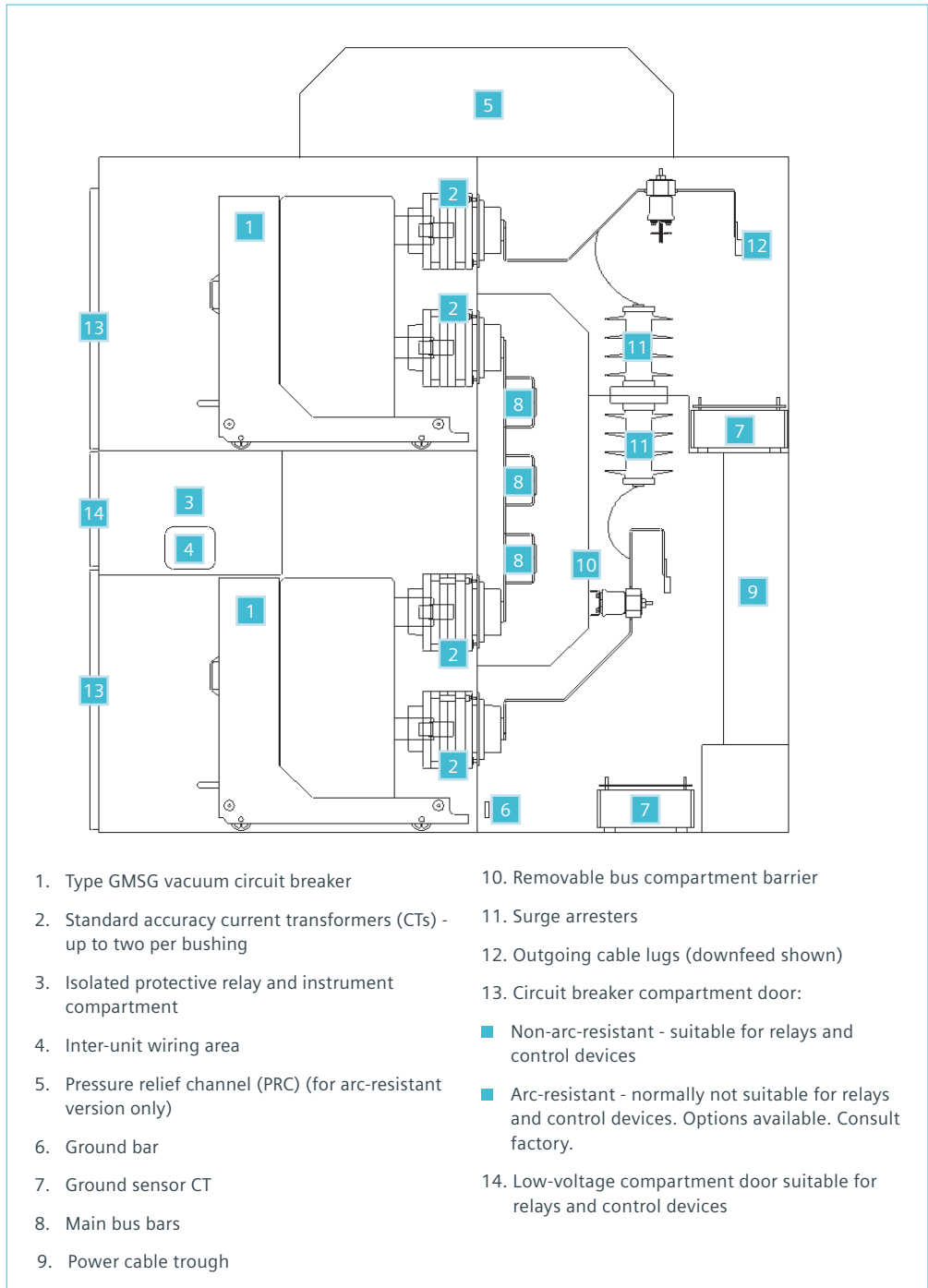

Figure 2: Types GM-SG or GM-SG-AR medium-voltage switchgear 1,200 A or 2,000 A circuit breaker section

Siemens type 3AH3 operating mechanism

The type GMSG circuit breaker uses the proven Siemens type 3AH3 stored-energy operating mechanism. This operator is an evolution of the type 3A family of operators first introduced in 1976. Over 60,000 type 3AH3 operating mechanisms have been produced since 1998.

Faster interruption

Standard interrupting time is five-cycles with an option available for three-cycle interrupting time.

Siemens vacuum interrupters

The vacuum interrupters used in the type GMSG circuit breaker are manufactured by Siemens and have been proven in thousands of installations since 1976. The chrome-copper contacts used in these vacuum interrupters are designed to assure low chopping levels and eliminate the need for surge protection on most circuits.

Front-mounted operating mechanism

The simple type GMSG operating mechanism makes maintenance and inspection easy. The mechanism is located on the front of the circuit breaker rather than underneath.

Maintenance intervals

If applied under ANSI “usual service” conditions, maintenance of the circuit breaker mechanism is designed to be needed at 10-year intervals.

Maintenance of the switchgear cubicle is recommended at five-year intervals and primarily consists of cleaning insulation.

Generator vacuum circuit breakers

Type GMSG-GCB generator vacuum circuit breakers can also be installed in types GM-SG and GM-SG-AR structures. These circuit breakers are derived from the basic type GMSG vacuum circuit breaker, but are specifically designed and tested to meet the requirements of IEEE Std C37.013 for generator circuit breakers.

Generator circuit breakers are not interchangeable with standard (non-generator) circuit breakers.

Floor rollout

No lift truck or dolly is needed to insert or remove circuit breakers in the lower cell of switchgear located at floor level. For indoor switchgear located on a raised “housekeeping” pad or for outdoor non-walk-in switchgear, a lift truck is required to handle circuit breakers.

“Universal” spare circuit breaker (up to 50 kA)

The physical configuration and interlock logic allow the use of a single circuit breaker to serve as a “universal” spare breaker at an installation site for up to 50 kA. The interlock logic checks the principal rating characteristics (continuous current, maximum voltage and interrupting current) and allows a circuit breaker to be inserted in any circuit breaker cell provided that the circuit breaker equals or exceeds the ratings required by the cell.

Generator circuit breakers are not interchangeable with standard (non-generator) circuit breakers.

“Universal” spare circuit breaker (63 kA)

The concept described above (for up to 50 kA) also applies for equipment rated 63 kA, within the 63 kA rating. Circuit breakers rated 63 kA cannot be used in equipment rated 50 kA or lower.

Generator circuit breakers are not interchangeable with standard (non-generator) circuit breakers.

Figure 3: Floor rollout/roll-in



Single source responsibility

Single source responsibility is assured since the complete equipment is designed by Siemens and is manufactured and tested in a single Siemens facility. The vacuum circuit breakers are checked in the switchgear cells as part of production testing. The vacuum circuit breakers are shipped in the switchgear to assure interchangeability and to reduce the possibility of damage to the circuit breakers during shipment.

Full ANSI design background

Full design integrity is managed and controlled by Siemens. ANSI/IEEE C37.09 and C37.20.2 require design tests on circuit breakers and structures together. The type 3AH3 operator design originates in Siemens' global center of competence for circuit breakers in Berlin, and final assembly of both the drawout type GMSG circuit breaker and the GM-SG family of switchgear occurs in a single facility. Siemens controls the entire process from design concept to production. Records are maintained to document compliance with ANSI/IEEE standards.

UL or C-UL Listing available

Where the arrangement of components allows, UL or C-UL Listing (for use in Canada) is available across the full range of the GM-SG family of switchgear.

Quality systems

Facilities involved with application, engineering, design and production are certified to ISO 9001 requirements.

Structural flexibility

Siemens GM-SG family of metal-clad switchgear provides enhanced flexibility in locating circuit breaker, auxiliary and metering cells within the structure layout. Circuit breakers rated 1,200 A, 2,000 A and 3,000 A may be located in upper or lower cell positions, except in GM-SG-AR arc-resistant equipment rated 63 kA, 3,000 A circuit breaker must be in lower cell.

Bus sectionalizing (tie) circuit breaker cells may be located on the upper or lower levels and are ordinarily located next to an auxiliary cell on the same level to accommodate transition bus work.

3,000 A circuit breakers up to 50 kA can be located either in the bottom cell or the top cell of a vertical section. For GM-SG-AR arc-resistant switchgear rated 63 kA, 3,000 A circuit breaker must be in lower cell.

If a 3,000 A circuit breaker is located in the lower cell, the upper cell may be used for metering devices only.

If a 3,000 A circuit breaker up to 50 kA is in the upper cell, the lower cell may be used to house a set of drawout voltage transformers, a drawout control power transformer or rollout fuses for a remote control power transformer.

The 3,000 A circuit breaker may be used for 4,000 A continuous current applications, with the addition of fan cooling equipment in the auxiliary cell above the circuit breaker. This application of fan cooling is appropriate if loads above 3,000 A are infrequent as, for example, in the case of a fan-cooled rating on a power transformer.

Each vertical section contains the main bus bar compartment plus a rear compartment for incoming and outgoing connections. The front portion of the vertical section contains a central protective relay and instrument compartment as shown in Figure 2: Types GM-SG or GM-SG-AR medium-voltage switchgear 1,200 A or 2,000 A circuit breaker section on page 5. The switchgear is normally designed so that additional vertical sections may be added in the future.

Enclosure design

The type GM-SG family design includes full ANSI/IEEE C37.20.2 metal-clad construction. This means complete enclosure of all live parts and separation of major elements of the circuit to retard the spread of faults to other compartments.

Removable plates permit access to all compartments. On non-arc-resistant versions, rear panels are individually removable to allow separate access either to downfeed or upfeed cable connections. On arc-resistant versions, rear panels are hinged and bolted.

The structure is constructed of bolted steel for better dimensional control than with welded designs. Sheet steel inter-unit barriers extend the full height and depth of each vertical section for isolating adjacent sections. The ground bus extends the entire length of the complete switchgear lineup and to all circuit breaker cells.



Figure 4: Stacking flexibility

Circuit breaker interchangeability

The type GM-SG family structures and the removable type GMSG circuit breaker element are both built to master fixtures so circuit breakers of the same ratings are interchangeable with each other even if the circuit breaker is required for use with a cell with “provisions only” supplied years earlier. The type GMSG circuit breaker is not interchangeable with the older designs.

A circuit breaker of higher rating (up to 50 kA) can be used in a cell of equal or lower rating. For example, a 3,000 A 50 kA 15 kV circuit breaker can be used in a 1,200 A 25 kA 15 kV circuit breaker cell. Additionally, circuit breakers are interchangeable between arc-resistant and non-arc-resistant cells.

The same is true for 63 kA rated circuit breakers. The 63 kA rated circuit breakers, however, can only be used in 63 kA rated cells, and lower rated circuit breakers cannot be used in 63 kA rated cells.

Generator circuit breakers are not interchangeable with standard (non-generator) circuit breakers.

Tested to ANSI/IEEE standards

Siemens type GM-SG switchgear is tested to meet the requirements of ANSI/IEEE standards. A complete design test program, including short-circuit interruption, load-current switching, continuous current, mechanical endurance, close and latch current, short time and momentary withstand, impulse withstand and the other tests required by the standards, has been successfully completed. These tests encompass the complete equipment design, including both the switchgear structure and the circuit breaker removable element.

Production tests in accordance with ANSI/IEEE standards are performed on every group of switchgear and on each circuit breaker. Certified copies of all test data can be furnished to customers upon request.

Type GM-SG non-arc-resistant switchgear is not classified as arc-resistant switchgear and has not been tested for resistance to internal arcing per IEEE C37.20.7.

Type GM-SG-AR arc-resistant switchgear is classified as arc-resistant switchgear and has been tested for resistance to internal arcing per IEEE C37.20.7 and has been qualified to carry a type 2B accessibility rating. The arc-resistant features are intended to provide an additional degree of protection to personnel in close proximity to the equipment in event of an internal arcing fault while the equipment is operating under normal conditions.

Qualification to seismic and wind loading requirements of various codes (for example, IBC, UBC and IEEE 693) is available. Consult Siemens with detailed requirements.

UL or C-UL Listing available

When specified, if the component configuration allows, the switchgear can be provided with a UL or C-UL (for use in Canada) label, indicating conformance to the requirements of ANSI C37.54 and ANSI C37.55.

Figure 5: Type GMSG 63 kA circuit breaker



Construction

Enclosures

The GM-SG family structures are constructed of bolted 11-gauge steel and feature slots and tabs to capitalize on CNC machinery for better dimensional control than welded designs have.

The structures are finished using a thermosetting polyester-powder coating with a textured appearance that is applied with electrostatic equipment. This method provides a durable finish that is highly resistant to marring and scratches. The standard finish is ANSI light gray. For surfaces exposed to weather, an additive is used to increase resistance to fading and improve salt-spray performance.

Interior plates for mounting control devices and wiring are finished bright white without texturing to allow for easy viewing of wiring.

To accommodate large quantities of incoming/outgoing cables, bolt-on rear extensions are available in 15" (381 mm) and 30" (762 mm) depths.

Pressure relief channel

The arc-resistant structures also feature exhaust channels between vertical sections that direct the hot gases overpressure and other arc by-products upward and into a top-mounted pressure relief channel (PRC), and away from personnel in close proximity to the equipment.

Once inside the PRC, the hot gases and arc by-products expand to reduce the overpressure. The PRC runs the entire length of a lineup of equipment and can be segregated internally to isolate groups of vertical sections of the lineup (for example, a tie-breaker section.)

The PRC is factory installed to reduce installation time and is compact to permit over-the-road transportation without the need for special permits or equipment.

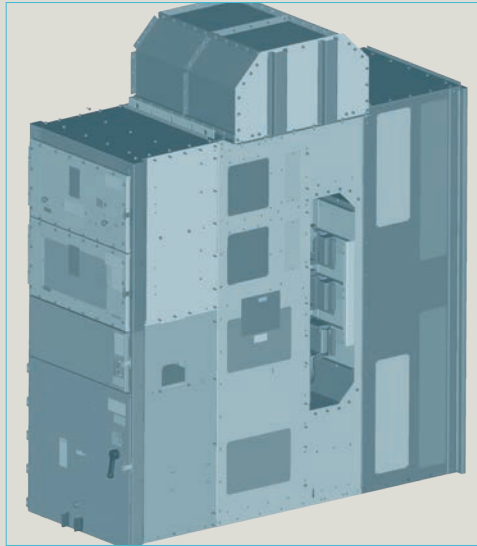

Figure 6: Type GM-SG-AR switchgear

Exhaust plenum

An exhaust plenum system attaches to the rear, front and sides or on top of the PRC (front connection must be coordinated with the circuit breaker lift truck) and carries the hot gases and arc by-products to the outside environment. One plenum run is required for every 14 vertical sections (for example, a lineup of 16 vertical sections would have the PRC segregated into two groups with a maximum of 14 and minimum of two vertical sections with one plenum for each group.)

For double-ended installations with a tie circuit breaker compartment in the middle of the lineup, two exhaust plenums are recommended to avoid contamination of both buses in the event of an arcing fault in one bus.

The plenum system is comprised of standard modular sections supplied assembled that are bolted together in the field to form a plenum run. The plenum run is designed to be suspended from the ceiling or supported from below similar to metal-enclosed bus duct.

Figure 7: Type GM-SG-AR switchgear



Many configurations are possible for the plenum system (for example, elbows and inclines); however, the plenum system must pass through an exterior wall horizontally to the outside environment (consult Siemens for a particular application). Siemens must provide the plenum system, however, does not supply the suspension/mounting components for the plenum system.

An exit section at the end of the plenum run is used to penetrate the exterior (non-combustible) wall of the building. It is designed to accommodate a wall thickness from 2" (51 mm) to 18" (457 mm) as standard, and is weather tight. On the exit section, an exhaust flap opens (in the event of an arcing fault due to the overpressure in the plenum) to allow gases and arc by-products to escape to the outside environment into a restricted access area with the minimum dimensions as presented in Figure 8: Installation of exhaust plenum exit on page 11.

Ventilation

Ventilation openings are provided on all GM-SG family structures and can be screened or filtered as an option. A minimum clearance of 10" (254 mm) above and 2" (51 mm) behind the equipment must be maintained to the nearest wall, equipment or other obstruction to allow for proper cooling of the equipment.

For the arc-resistant structures, these ventilation openings feature internal flaps that close in the event of internal arcing to minimize the escape of hot gases through these openings. In addition to clearances required for ventilation, arc-resistant structures require clearances around the equipment for personnel safety as follows:

- If the switchgear is installed with working space to the rear of the equipment that could be occupied by maintenance, operating or other personnel, a minimum of 37" (940 mm) of clearance must be provided from the switchgear to the nearest wall, equipment or other obstruction.
- If the switchgear is installed with working space beside the equipment that could be occupied by maintenance, operating or other personnel, a minimum of 24" (610 mm) of clearance must be provided from the switchgear to the nearest wall, equipment or other obstruction.
- If the switchgear is installed with space beside the equipment and this space is designated and blocked so that maintenance, operating or other personnel are excluded from the space, a minimum of 6" (152 mm) of clearance must be provided from the switchgear to the nearest wall, equipment or other obstruction.
- If the switchgear is installed inside a power equipment center (or powerhouse) or similar outer enclosure, where access to the rear of the equipment is provided by means of doors or removable panels on the outer enclosure, a minimum of 6" (152 mm) of clearance must be provided between the rear most extension of the ventilation openings on the switchgear and the enclosure.

Figure 8: Installation of exhaust plenum exit

| Identification | Description |
|----------------|---|
| A | Exhaust plenum section |
| B | 3/8-16 hardware |
| C | Exhaust exit section |
| D | Exhaust flap closed |
| E | Screw may be removed if inside a wall |
| F | Exhaust flap open |
| G | Wall (non-combustible) |
| H | Field caulk all around |
| I | Fenced (or otherwise protected) area with restricted access |
| J | Exterior (building) |
| K | Exhaust plenum exit |

The detail below shows the minimum recommended clearance from the exhaust plenum exit. When the equipment is operating, this area should be kept clear of personnel and/or combustible or flammable materials.

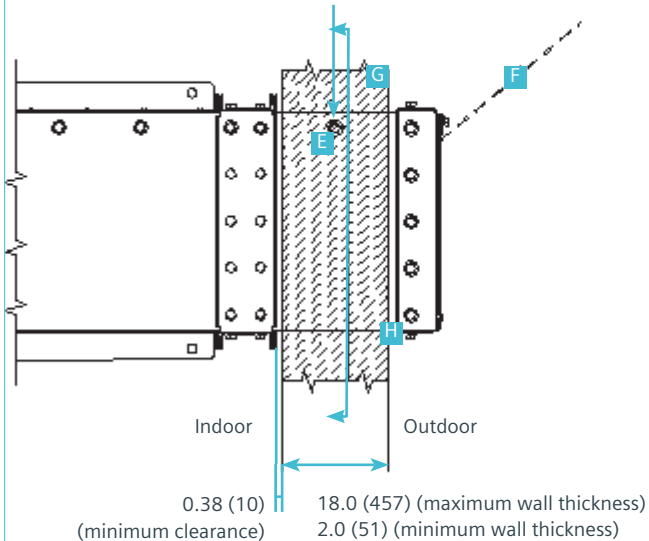
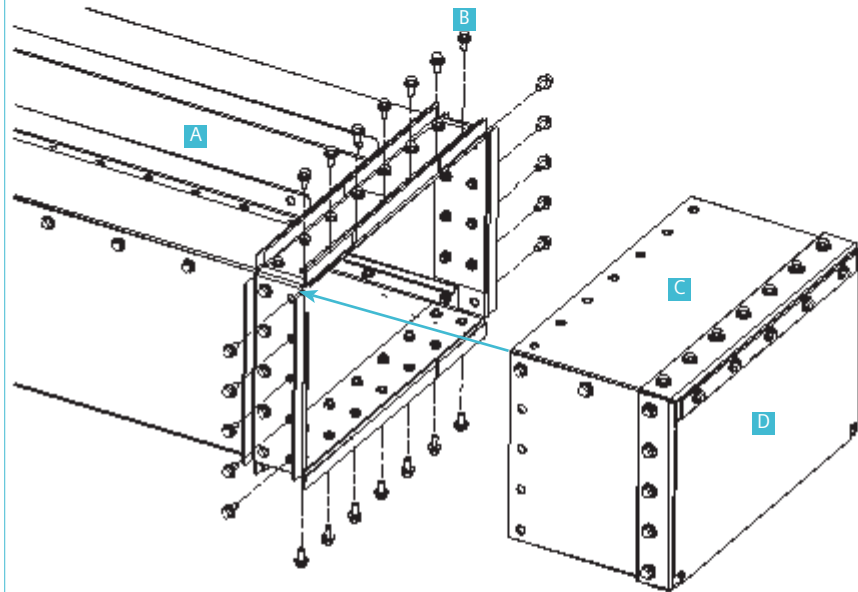
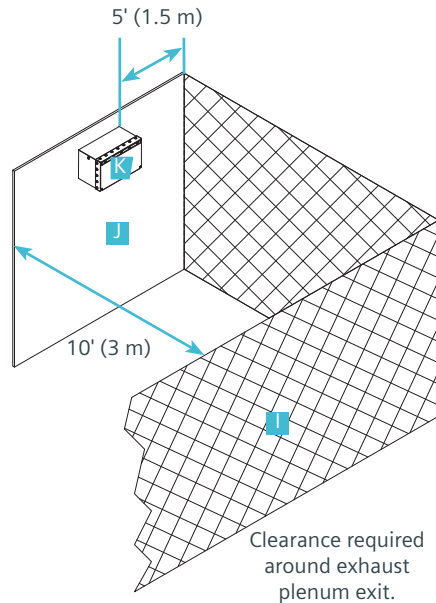

Dimensions in inches (mm)

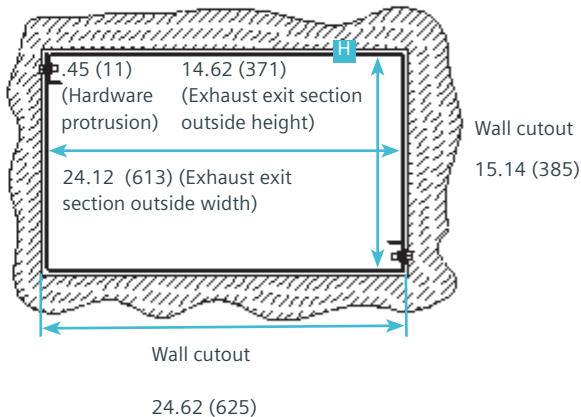



Figure 9: Cable trough in lower cable compartment to isolate cables from circuit breaker in upper compartment



Figure 10: Central compartment for panel devices



Figure 11: Electric racking accessory



Switchgear compartments

Vacuum circuit breaker cell

The circuit breaker cell is a bolted, reinforced, sheet steel enclosure with provisions for a type GMSG vacuum circuit breaker. It includes a hinged front door, inter-compartment and inter-unit barriers, primary and secondary disconnects, racking mechanism, interlocks, instruments and relays, control wiring and devices and current transformers, as required by the application.

Vacuum circuit breaker element

The type GMSG vacuum circuit breaker includes a stored-energy operating mechanism, primary and secondary disconnects, auxiliary switch, ground contact, control wiring and interlocks.

Auxiliary cell

An auxiliary cell is similar to a circuit breaker cell, except without provisions for a circuit breaker. Space may be used for voltage transformers (VTs), control power transformers (CPTs) or rollout fuse trays, or other auxiliary devices.

For type GM-SG non-arc-resistant switchgear, the front panel is hinged.

For type GM-SG-AR arc-resistant switchgear, the front panel is hinged and also interlocked with the VT, CPT or rollout fuse tray, so that the rollout tray must be withdrawn (disconnected) before the compartment door can be opened.

Bus compartment

The bus compartment is a separately enclosed space for three-phase insulated main power bus bars, supports and connections to circuit breaker and auxiliary cells.

Primary termination compartment

The rear area of the unit includes space for connecting incoming or outgoing power cables, bus duct connections, transformer connections or surge protection devices. In stacked configurations, outgoing power connections for the upper cell are isolated from those for the lower cell.

Circuit breaker cell features

Relay and instrument space

For non-arc-resistant equipment, the circuit breaker cell front door is suitable for mounting the most common relays, meters, test switches, control switches and similar devices typically used on metal-clad switchgear.

For arc-resistant equipment, the circuit breaker cell front door space is not normally suitable for protective relays and control devices. Consult factory for available options.

Closed door racking

The circuit breaker can be racked in or racked out with the cell door open or closed.

For non-arc-resistant equipment and for arc-resistant equipment, the mechanism includes an indicator to show the racking mechanism position with the door closed.

For arc-resistant equipment, the circuit breaker is interlocked so that it can be racked only with the compartment door closed and latched.

For racking, a manual drive crank or an optional electric motor drive may be used for either type of equipment.

Siemens integrated electric-racking system (SIERS) (optional)

An electrical racking system integrated into the racking mechanism of a circuit breaker (or 63 kA rollout tray in arc-resistant GM-SG-AR switchgear) compartment is optionally available. The SIERS system allows an operator to control the racking of a circuit breaker (or 63 kA rollout tray in arc-resistant GM-SG-AR switchgear) from a remote location (outside the arc-flash boundary) without the need to install a portable racking accessory. This reduces the need for personal protective equipment required by NFPA-70E®.

The SIERS system is available in three configurations:

1. Basic: Each circuit breaker cell is equipped with an integrated electric-racking system, which includes a fixed-mounted, high-torque gear motor and logic-control module. A control pendant is provided, and a compartment mounted connector for supplying control power from the switchgear, or from an external supply (either 120 Vac or 125 Vdc). Typically, one control pendant is supplied per lineup.

2. Local HMI: Basic type as in configuration 1 plus local HMI panel personal computer (PC) interface for use with the user's PC.
3. SCADA: Basic type as in configuration 1 plus custom interface with SCADA or other control system.

For further information, refer to instruction manual EMMS-T40013-XX-XXXX

Portable electrical racking accessory (optional)

A portable electrical racking motor accessory is available. This consists of a motor drive assembly which installs (without tools) on mounting brackets on the switchgear front panel of a circuit breaker (or 63 kA rollout tray) compartment. The unit includes a power cord, which can be plugged into a duplex receptacle in the vicinity of the switchgear, plus a control cable, which allows the operator to control the racking operation from a distance. An alternative arrangement is available, which includes a control box that can be mounted at a distance from the switchgear and permanently connected to control power. In turn, the racking motor can be connected to the control box with a long cord.

Floor rollout

Circuit breakers in the lower cell can be rolled out directly on the floor in front of the unit without a handling device, lift truck, or hoist for indoor (if not on raised "housekeeping" pad) and Shelter-Clad installations. A lift truck accessory is optionally available for handling circuit breakers (or 63 kA rollout trays) in upper cells or in non-walk-in outdoor enclosures.

Current transformers

Front-access current transformers may be mounted around both the upper and lower stationary primary disconnect bushings. Up to four standard accuracy current transformers per phase may be located in each circuit breaker cell.

Interlocks

Interlocks prevent moving a closed circuit breaker in the cell by preventing engagement of the racking crank (or electric racking accessory) if the circuit breaker is closed.

A second interlock lever holds the circuit breaker mechanically and electrically trip free between positions. The racking mechanism can be padlocked to restrict unauthorized racking of the circuit breaker.

Additional interlocks for arc-resistant equipment prevent racking of a circuit breaker in the cell unless the cell door is closed and latched.

Separate padlock provisions may be used to hold the circuit breaker in the trip-free condition.

Automatic shutters

Automatically operated grounded steel shutters allow or block access to the stationary primary disconnects. The shutters are opened by the circuit breaker as it moves toward the connected position. The shutters close as the circuit breaker is racked away from the connected position to the test position. The shutters remain closed until they are forced open by insertion of the circuit breaker. This design enhances protection for personnel compared to shutters that are only linked to the racking mechanism only.

Primary disconnects

The cubicle stationary primary disconnect contacts are recessed inside insulated assemblies and are located behind grounded steel shutters to prevent accidental contact when the circuit breaker is withdrawn. The primary disconnect finger clusters are mounted on the circuit breaker.

Secondary disconnects

The cubicle-mounted stationary disconnect contacts mate with spring-loaded secondary contacts on the side of the circuit breaker. The secondary disconnects automatically engage in both the test and connected positions and they remain engaged between these positions.

Mechanism-operated cell (MOC) switch

When required, up to 24 stages of the MOC auxiliary switch can be mounted in the circuit breaker cell. All spare MOC contacts are wired to accessible terminal blocks for user connections. These MOC switches are operated only when the circuit breaker is in the connected position. Optionally, they may be arranged to operate in both the connected and test positions.



Figure 13: Type MD CTs installed on lower disconnect bushings (CT barrier removed for photo)

Figure 14: Circuit breaker cell interior

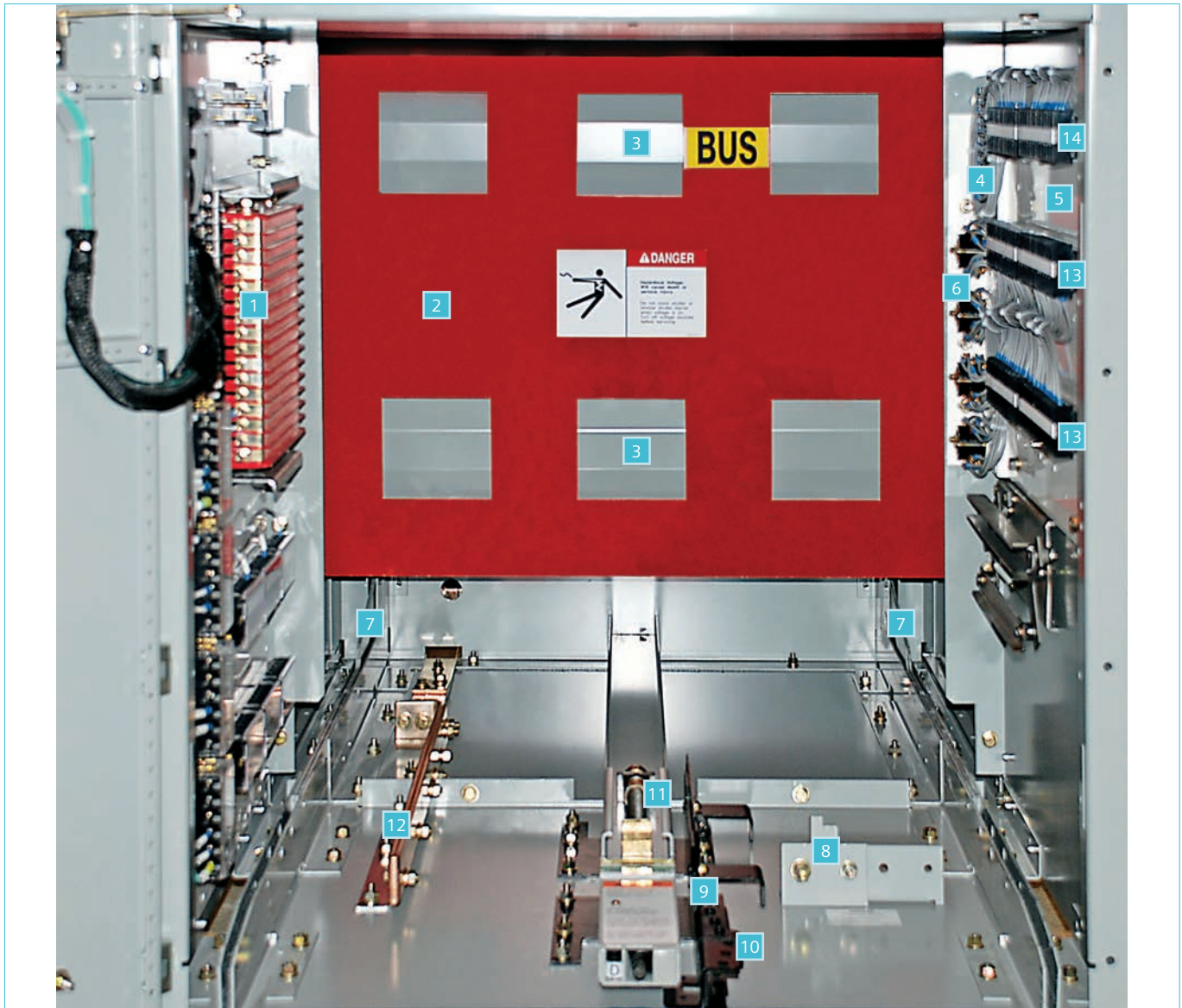

- | | |
|---|--|
| 1. Secondary disconnect | 10. Racking mechanism padlock provisions |
| 2. Current transformer barrier | 11. Racking mechanism |
| 3. Shutters, primary disconnects (behind shutters) and current transformers (behind shutters) | 12. Ground bar |
| 4. Truck-operated cell switch (TOC) (optional) | 13. MOC terminal blocks |
| 5. White interior device panel | 14. TOC terminal blocks |
| 6. Mechanism-operated cell switch (MOC) (optional) (cover removed for photo) | |
| 7. Shutter operating linkage | |
| 8. Ratings interlock | |
| 9. Trip-free padlock provisions | |

Truck-operated cell (TOC) switch

When required, up to 12 stages of TOC switch can be mounted in the circuit breaker cell. All spare TOC contacts are wired to accessible terminal blocks for user connections.

Unobstructed terminal block space

Terminal block areas are located on each side of circuit breaker or auxiliary cells. Since the racking system components are not mounted on the cubicle sides, the side-mounted terminal blocks are not obstructed as in other designs. Installation of field wiring is simplified, as wiring can be easily laid directly against the side sheets. It is not necessary to “fish” the wiring under, around or through obstructions.

Secondary control devices

The secondary control devices for the upper and lower circuit breaker cells are located in the protective relay and instrument cell. The cell can accommodate pullout fuse holders or molded case breakers to suit the protective practices of the purchaser and can also accommodate auxiliary relays, transducers or similar devices.

On arc-resistant versions of the type GM-SG family of switchgear, the door to the central protective relay and instrument cell and other low-voltage cells can be opened to access internal components while the equipment is operating, as the design has passed the requirements of ANSI/IEEE C37.20.7 (accessibility type 2B) with the low-voltage compartment door open.

Auxiliary cells

Auxiliary cells are constructed in a similar manner as the circuit breaker cells, except without provisions for a circuit breaker element. Auxiliary cells may be located in the top or bottom of a vertical section.

The cubicle portion of the cell may be used for mounting devices such as voltage transformers, control power transformers, automatic transfer switches or other auxiliary devices.

Rollout trays may be included for mounting VTs, CPTs or fuses for fixed-mounted CPTs.

For non-arc-resistant versions of the equipment, opening of the front door does not automatically disconnect the VT, CPT or rollout fuse trays located inside the cell.

For arc-resistant versions of the equipment, the front door is interlocked to prevent opening unless the rollout tray is in the disconnected position.

Auxiliary cell relay and instrument space

The auxiliary cell’s front panel is suitable for mounting of devices.

If the auxiliary cell contains rollout tray devices (VTs, CPT or rollout fuses), the space available allows for mounting of devices with limited depth, for example, test switches, instruments, transfer switches, etc., and can accommodate many relay types with the use of a projection frame. If the auxiliary cell does not contain a rollout tray, the panel is suitable for mounting any of the devices commonly specified for use on metal-clad switchgear.

For arc-resistant versions of the equipment, the front panels of VT, CPT or rollout fuse tray cells are not available for relays or control devices as standard.

Voltage transformers (VTs)

Up to three VTs (single-fused) with their integrally mounted current limiting fuses may be mounted on each rollout tray. The upper and lower cells can each accommodate up to two rollout trays (up to 50 kA). When moving to the disconnect position, the primary fuses are automatically disconnected and grounded to remove any static charge from the windings. The secondary connections are also disconnected when the rollout tray is moved to the disconnect position. When the rollout tray is withdrawn, insulated shutters cover the cubicle primary disconnects providing additional protection to personnel from exposure to energized components.

Control power transformers (CPTs)

One single-phase CPT of up to 15 kVA capacity, with its primary current limiting fuses, may be mounted on the rollout tray of an auxiliary cell. The secondary molded case breaker is interlocked with the rollout tray such that the secondary breaker must be open before the CPT primary can be disconnected or connected. This prevents load current interruption on the main primary contacts.

With the secondary breaker open and the latch released (for 50 kA rated equipment), the tray can be rolled easily to the disconnect position. As the tray rolls out, the primary fuses are automatically grounded to remove any static charge, and insulated shutters close to shield energized conductors.

For type GM-SG non-arc-resistant switchgear, the secondary molded-case circuit breaker is mounted on the rollout tray.



Figure 15: Type GM-SG non-arc-resistant, showing VT rollout tray withdrawn to allow inspection of fuses



Figure 16: Type GM-SG-AR VT rollout tray cell (up to 50 kA) showing VT insertion/withdrawal tools in use

For type GM-SG-AR arc-resistant switchgear, the secondary molded-case circuit breaker is located in the central protective relay and instrument cell and key interlocked with the CPT rollout tray.

Large single-phase and all three-phase CPTs are stationary mounted in the rear of the vertical section. The primary fuses for these large transformers are mounted on the rollout tray in an auxiliary cell and key interlocked with the secondary breaker. Withdrawing the rollout tray closes insulated shutters.

63 kA arc-resistant equipment

For arc-resistant equipment rated 63 kA, each rollout tray (for VTs, CPT, or CPT fuses) occupies a full upper or lower compartment as shown in the right-hand portion of Figure 17.

Figure 17: Auxiliary cells

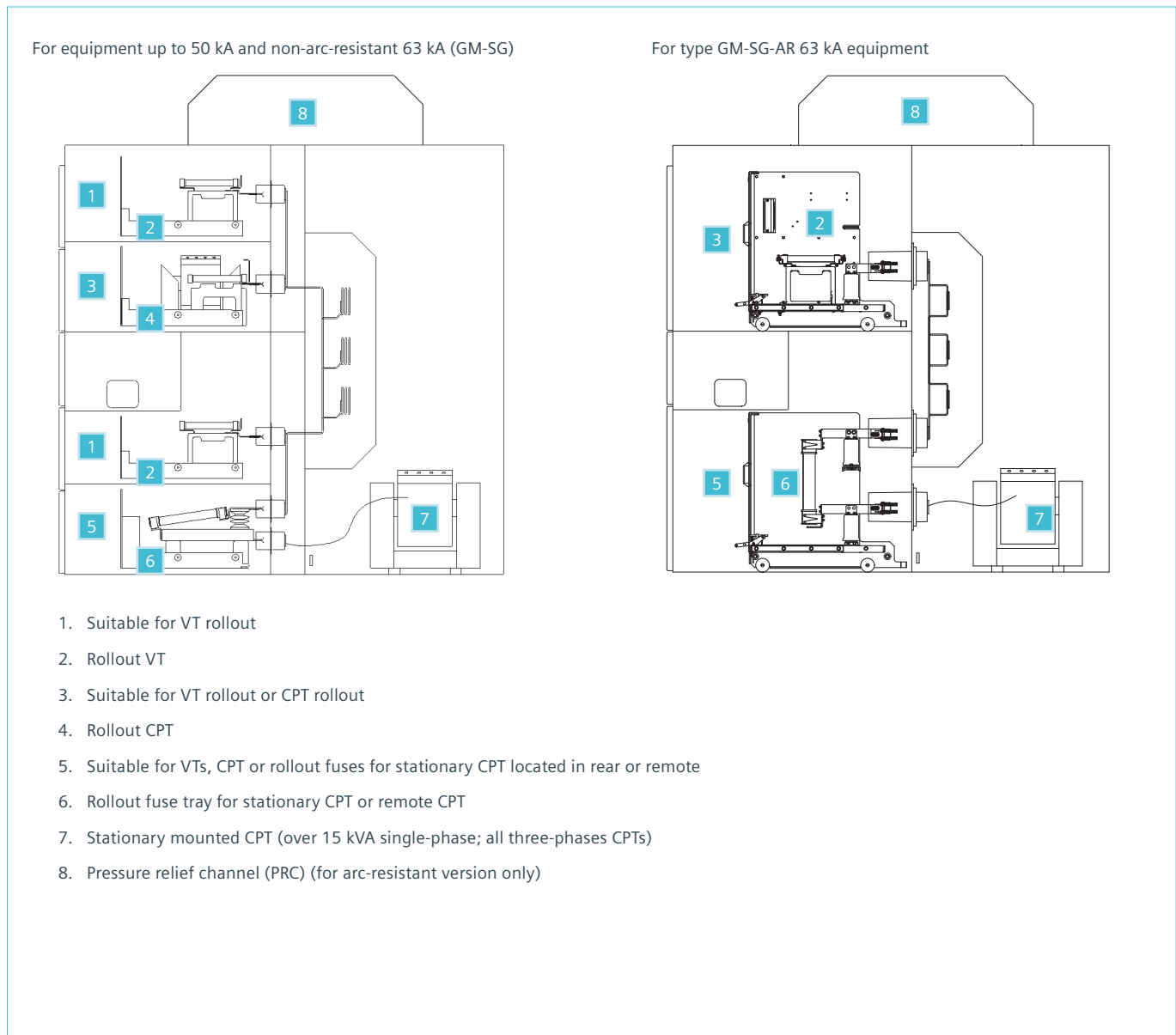

Current transformers (CTs)

Siemens toroidal CTs comply with ANSI/IEEE standards and are mounted at the rear of the circuit breaker cell. Up to four standard accuracy type MD CTs may be mounted on each phase: two on the bus side and two on the load side, around the primary disconnect bushings. CTs may be added or changed with the cell de-energized without removing the bus bar or cable connections. Multi-ratio CTs are available.

For higher accuracy, type MDD CTs are available. Due to their larger physical size, only one MDD CT can be installed on each side of the circuit breaker.

Primary termination compartment

The primary termination compartment is located at the rear of the switchgear and is separated from all other compartments by metal barriers. When two circuit breakers are located in the same vertical section, their primary cables are separated by steel horizontal barriers and by an enclosed vertical cable trough when both sets of cables exit in the same direction. Removable plates permit access to all compartments.

On non-arc-resistant versions, rear panels are individually removable to allow separate access either to downfeed or upfeed cable connections.

On arc-resistant versions, rear panels are hinged and bolted.

Infrared (IR) viewing windows are optionally available for use in checking the temperature of conductors in the primary termination compartment.

Bus bar system

The main bus bar system is enclosed by grounded metal barriers and feeds both the upper and lower cells in a vertical section. Siemens offers full-round-edge copper bus bar with silver-plated joints as standard. Tin-plated copper bus is available as an option. High-strength grade 5 steel hardware with split lock washers helps maintain constant pressure, low-resistance connections. A copper ground bus bar is standard in all vertical sections.

Bus bar insulation

Bus bars have fluidized bed, flame-retardant, track-resistant, epoxy insulation with higher track-resistant properties. The epoxy is bonded to the bus bars to reduce the possibility of corrosion due to intrusion of gas or moisture between insulation and bus bar.

Bus joint insulation

For normal joint configurations, bolted bus joints are insulated by pre-formed, molded polyvinyl boots that are held in place by nylon hardware. Preformed insulating materials eliminate the need for taping joints when connecting shipping groups in the field, reducing installation time and costs. The same preformed, high-dielectric strength joint boots used in factory assembly are also used in field assembly of shipping split bus connections. For uncommon joint configurations, taped joint insulation is used. Boots for insulating user's power connections are available as an option.

Bus support insulation

Track-resistant, flame-retardant, glass-polyester insulation components are used to produce a uniform and high quality insulation system. Bus bar supports and primary disconnect bushings are molded from high-impact strength insulation with high-dielectric strength and low moisture absorption (non-hygroscopic) characteristics.

As an option, a high track-resistance material is also available.

Secondary wiring

Secondary wiring is neatly bundled and secured on the sides of the cell. Wiring is not routed on the floor of the switchgear as in some other manufacturers' designs.

Wiring

The secondary and control wiring is connected to terminal blocks, which have numbered points for identification. One side of the terminal blocks for all connections leaving the switchgear is reserved for external connections. Secondary and control wire is minimum no. 14 AWG, extra flexible, stranded type SIS wire, insulated for 600 volts, except when devices (for example, transducers, communicating devices, etc.) require different wire. Insulated barrel, crimp-type locking fork terminals are used for most applications except where the devices require a different type of terminal. Secondary control wires are armored or enclosed in grounded metal wire covers or sheaths when they pass through primary compartments.

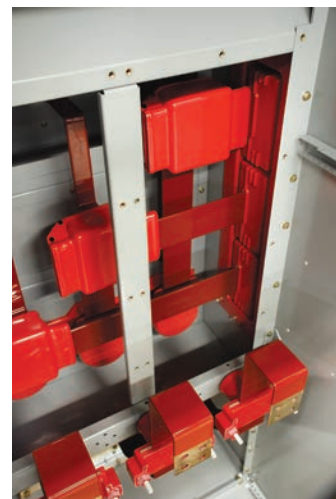

Figure 18: Main bus configuration



Figure 19: Protective relay and instrument cell interior



Figure 20: Circuit breaker cell wiring and secondary disconnects

Instrumentation and relays

Instruments, meters and relays can be traditional switchboard type or modern electronic type, depending on the requirements of the specification. If traditional electromechanical devices are used, they have semi-flush cases with dull black covers. Indicating and recording instruments, meters and relays are semi-flush mounted rectangular type. All scales have a suitable range and are designed with black letters on a white background.

Control and instrument switches

Furnished switches are rotary, switchboard type with black handles. Circuit breaker control switches have pistol-grip handles, while instrument transfer switches have round notched handles and auxiliary or transfer switches have oval handles.

Circuit breaker control switches have a mechanical flag indicator showing a red or green marker to indicate the last manual operation of the switch.

Outdoor housings

Three types of outdoor housings: non-walk-in, Shelter-Clad, and Shelter-Clad+ are available to meet almost any application. For all types, the underside of the base is coated with a coal tar emulsion. The switchgear is shipped in convenient groups for erection in the field.

Non-walk-in design (non-arc-resistant only)

The non-walk-in switchgear consists of indoor type circuit breaker and auxiliary cubicles located in a steel housing of weatherproof construction. Each vertical section has a full height exterior front door with provision for padlocking. Each cell is also equipped with an inner-hinged front door for mounting relays, instrumentation and control switches. Two removable rear panels are included for cable access to the primary termination area. Each cubicle includes necessary space heaters, a switched lamp receptacle for proper illumination of the cubicle during maintenance and inspection and a duplex receptacle for use with electric tools. A molded-case circuit breaker for space heaters is located in one cubicle.

Shelter-Clad single-aisle design

The Shelter-Clad switchgear (for non-arc-resistant or arc-resistant types) consists of indoor type circuit breaker and auxiliary cubicles located in a weatherproof steel housing with an operating aisle space of sufficient size to permit withdrawal of the circuit breakers for inspection, test or maintenance. An access door is located at each end of the aisle arranged so that the door can be opened from the inside regardless of whether or not it has been padlocked on the outside. The aisle space is furnished with incandescent lighting, controlled through a three-way switch at each access door. Each cubicle includes necessary space heaters. Each lineup includes two utility duplex receptacles, one at each aisle access door, for use with electric tools, extension cords and other devices. The weatherproof enclosure for the aisle is shipped assembled.

The arc-resistant version includes an integral exhaust plenum system to exhaust hot gases, overpressure and arc by-products associated with an internal arcing fault.

Shelter-Clad+ single-aisle design

Shelter-Clad+ outdoor equipment (for non-arc-resistant or arc-resistant types) consists of indoor equipment enclosed in a weather-resistant housing complete with a walk-in aisle, an exhaust system to direct the arc-fault products outside of the enclosure in the event of an internal arcing fault (arc-resistant type only), a common base, and many optional features typically only available in power equipment centers (PECs) such as HVAC systems, indoor and outdoor lighting, insulation, work spaces, and alarm systems. Shelter-Clad+ switchgear assemblies are built in partnership with Siemens-qualified vendors, who provide detailed drawings of each custom assembly which include lifting, handling, support, and installation instructions. Please be sure to carefully review and follow all instructions provided in the order-specific Shelter-Clad+ drawing package.

Accessories

Accessories

Standard accessories include:

- Manual racking crank
- Spring charging crank
- Drawout extension rails (to enable handling of circuit breakers or auxiliary rollouts in upper cells or above floor level)
- Lift sling (for circuit breakers or rollout trays above floor level)
- Split plug jumper (standard unless test cabinet is furnished)
- Contact lubricant
- Touch-up paint
- Auxiliary rollout tray insertion/withdrawal rods (arc-resistant up to 50 kA)
- Circuit breaker manual trip rod (arc-resistant up to 63 kA).

Optional accessories include:

- Circuit breaker lift truck
- Adapter for lift truck, for lifting auxiliary rollout trays for GM-SG (up to 63 kA) or GM-SG-AR (up to 50 kA)
- Test cabinet (in place of split plug jumper)
- Test plugs (if required by devices)
- Portable electric racking motor assembly (to enable racking while operator is at a distance from the switchgear)
- Manual or electrical ground and test device.

Test provisions, either a split plug jumper or a test cabinet, are available for testing the circuit breaker outside its cubicle.

The split plug jumper is used to bridge the secondary disconnects with a flexible cable, so the circuit breaker may be electrically closed and tripped with the control switch on the instrument panel while the circuit breaker is outside of its compartment. The test cabinet, including a control switch, is used for closing and tripping the circuit breaker at a location remote from the switchgear.



Figure 21: Accessory cabinet



Figure 22: Type GMSG circuit breaker on lift truck

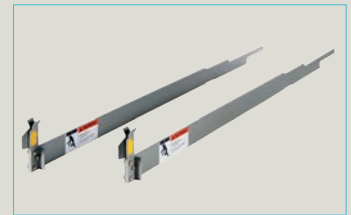

Figure 23: Drawout extension rails



Figure 25: SIERS hand-held control pendant



Figure 24: For arc-resistant equipment: rollout tray insertion/withdrawal tools up to 50 kA and manual trip rod (up to 63 kA)

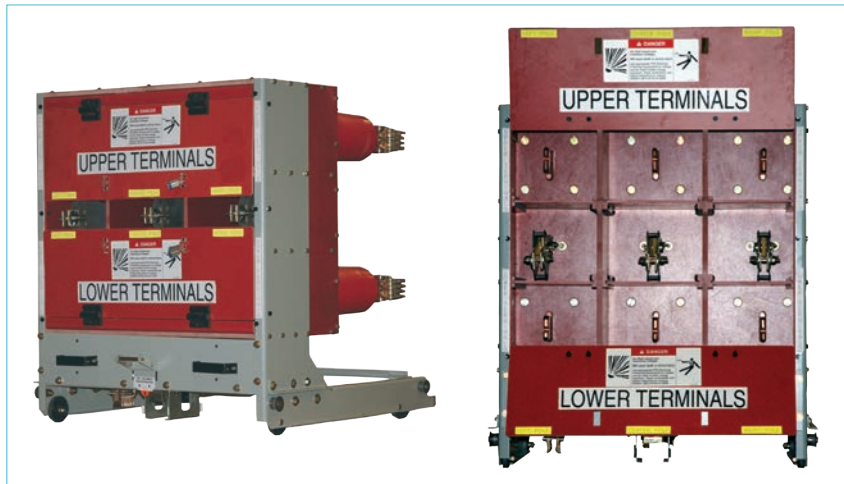

Figure 26: Type GMSG-MO manually operated ground and test device

Note: Due to the special nature of ground and test devices, each user must develop definitive operating procedures for incorporating safe operating practices. Only qualified personnel should be allowed to use ground and test devices.

Manually operated ground and test device (up to 50 kA), type GMSG-MO

The type GMSG-MO ground and test device (up to 50 kA) is a drawout element that can be inserted into a circuit breaker cell rated for a short-circuit current of 50 kA or lower. The type GMSG-MO device opens the shutters, connects to the cell primary disconnecting contacts and provides a means to make the primary disconnect stabs available for testing or grounding. The type GMSG-MO device is suitable for high-potential testing of outgoing circuits of the switchgear main bus or for phase sequence checking. The type GMSG-MO device also provides a means to connect temporary grounds to de-energized circuits for maintenance purposes.

The manual ground and test incorporates three-position, single-pole switches (upper stabs to ground, neutral and lower stabs to ground), eliminating the need for user-furnished ground cables. The switches are hookstick operable and, in the closed position, are rated for the full momentary and short-time ratings of the associated switchgear. User-furnished grounding cables and commercially available ground clamps seldom have ratings equal to those of the switchgear.

Separate insulated hinged panels cover the upper and lower stabs and include padlock provisions. The type GMSG-MO device also includes individual hookstick-removable barriers between each single-pole switch and the upper stabs and lower stabs.



Figure 27: Type GMSG-EO electrically operated ground and test device

Electrically operated ground and test device (for up to 50 kA and for 63 kA), type GMSG-EO

An electrical ground and test device includes a power-operated switch (derived from a type GMSG circuit breaker) arranged to allow grounding one set of disconnect stabs. These devices are able to close and latch against short-circuit currents corresponding to the ratings of the equipment.

The electrically operated ground and test device rated for a short-circuit current of 50 kA can be used in any type GM-SG family circuit breaker compartment rated up to 50 kA.

The 63 kA device can be used only in type GM-SG family circuit breaker compartments rated 63 kA.

Neither the 50 kA device nor the 63 kA device require any adapters for use in cells.

Two devices, one each for the upper and lower stabs, are required if grounding is desired to either side of the unit. The type GMSG-EO device also provides a means of access to the primary circuits for high potential tests or for phase sequence checking.

Due to the unique requirements frequently involved in such devices, all applications of electrically operated ground and test devices should be referred to Siemens for review.

Protective relays

Type SIPROTEC™ protective relays

Type SIPROTEC protective relays have established themselves across the market as the standard for numerical protective relaying. Besides the common system platform and the unique type DIGSI 4 service interface that may be used for all protective devices, it also supports the new IEC 61850 communication standard.

What is IEC 61850 and what can it achieve?

Users and manufacturers jointly developed the international standard IEC 61850, which was approved in 2004. The agreed aim of this standard is to arrive at a complete communication solution for substations, thus providing users with interoperability among different makes on the basis of Ethernet technology. This opens up a whole new dimension in efficient substation management. Not only short-term savings in operation and maintenance but also simplified engineering, less complexity and long-term expandability can make your company one of the winners in tomorrow's power market.

With type SIPROTEC protective relays and bay control units from Siemens, we offer all the advantages of an expert and innovative partner in the field of protective relaying and substation automation. Siemens provides attractively priced intelligent solutions by paying particular attention to lowering your life cycle and system management costs. These solutions are the first ones on the market complying with the international IEC 61850 standard.

To enable your company to profit from these advantages as quickly as possible, Siemens collaborated in the preparation of this international standard and made every effort to ensure no time was lost in bringing it to the market.

The result is certainly worth consideration, because type SIPROTEC protective relays and other Siemens power automation products and systems are available on the basis of the IEC 61850 standard and can even be retrofitted in systems supplied since 1998.



Figure 28: Type GM-SG protective relay and instrument compartment

System advantages: one bay, one unit

The SIPROTEC 4 protective relay family offers fully integrated protection, control, monitoring and automation functions incorporated in a single device. For many applications, this product contains all the functions you need to meet all your protection and control requirements with just one unit per bay, saving on investment and installation costs while enhancing availability.

DIGSI 4

The DIGSI 4 computer program is a powerful analysis tool that speeds up troubleshooting and supplies important service information. From setting and commissioning of devices to the documentation and analysis of system faults, Siemens' DIGSI 4 offers a universal tool for all support tasks.

Vacuum circuit breakers

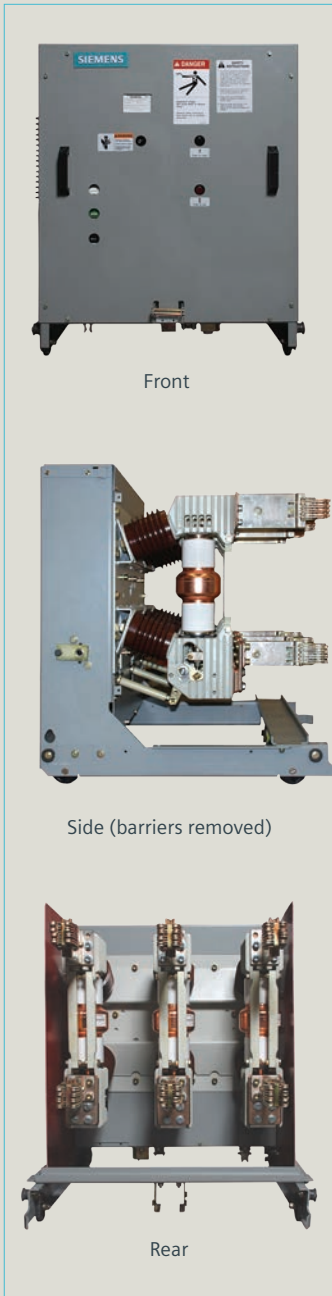

Front

Side (barriers removed)

Rear

Figure 29: Type GMSG vacuum circuit breaker

Vacuum circuit breaker ratings

Siemens type GMSG circuit breakers are available in 25 kA through 63 kA “constant kA” interrupting classes or 250 MVA through 1,000 MVA on the older “constant MVA” rating basis. Continuous current ratings include 1,200 A, 2,000 A and 3,000 A self-cooled. 4,000 A is available using a 3,000 A circuit breaker together with forced-air (fan) cooling in the switchgear cubicle (indoor only).

Common operator family

Since the entire type GMSG circuit breaker range of ratings uses a common stored-energy operating mechanism design, less training of maintenance personnel is required and stocking of spare parts is reduced.

Floor rollout

If the switchgear is not located on a “housekeeping” pad, the circuit breakers located in the lower cells are arranged to rollout directly on the floor in front of the switchgear. No adapter, hoist or lift truck is necessary.

Maintenance features

Type GMSG circuit breakers incorporate many features designed to reduce and simplify maintenance, including:

- Low maintenance vacuum interrupter
- Ten-year maintenance interval (assuming ANSI “usual service” conditions)
- Floor rollout
- Front-mounted operator
- Common operator family
- Simple outer-phase barriers
- “Universal” spare circuit breaker concept
- Non-sliding current transfer
- Rugged secondary disconnects.

Ten-year maintenance interval on type GMSG circuit breaker

When applied under mild conditions (ANSI “usual service” conditions), maintenance is typically needed at 10-year intervals on the circuit breaker. The maintenance interval for the switchgear cubicles is five years.

Low-maintenance requirements

The vacuum interrupter is a sealed unit so the only maintenance typically required is to remove contaminants and check the vacuum integrity. The vacuum interrupters can be disconnected from the stored-energy mechanism quickly without tools. The vacuum integrity may be checked by hand or, alternatively, a simple high-potential test can be used.

Mechanism operation

The mechanism is arranged to pre-store closing energy in the closing springs. The closing springs are selected so that they provide sufficient energy not only to close the circuit breaker safely into maximum “close and latch” currents but also to pre-store the tripping energy necessary to open the circuit breaker. The closing springs can be manually charged during maintenance or in emergency conditions, but are normally charged electrically automatically after each closing operation.

Front accessible operating mechanism

The type GMSG stored-energy operator is located at the front of the circuit breaker. The front cover can be easily removed to expose the operator for inspection and maintenance. This feature eliminates the need to lift, tilt or turn over the circuit breaker for normal service.

Interlocks

The interlock system prevents racking of a closed circuit breaker and prevents the closing of the circuit breaker between the “test” and “connected” positions. The racking mechanism can be padlocked to prevent unauthorized operation. Padlocks can also be applied to the racking mechanism to maintain the circuit breaker in the trip-free condition.

Stored-energy operator

The type GMSG circuit breaker utilizes the Siemens type 3AH3 stored-energy operator for long life, high reliability and ease of maintenance. Parts used in the manufacturing of the circuit breaker are precision tooled or produced on numerically controlled equipment. The circuit breaker design includes frequent use of inherent alignment techniques.

Manual controls and indicators

All circuit breaker manual controls and indicators are conveniently located on the front of the circuit breaker.

Standard features include manual close button, manual trip button, open-close indicator, stored-energy closing spring charge/discharge indicator, manual spring charging access port and close operation counter.

Trip-free design

The operating mechanism conforms to the trip-free requirements of ANSI/IEEE standards. The mechanism design assures that the tripping function prevails over the closing operation.

Simple barriers

Outer phase barriers are of very simple design and located on the circuit breaker, allowing the cell to be free of barriers, except the current transformer barrier located in front of the shutters. The barriers on the circuit breaker remove quickly and easily for maintenance. Most maintenance can be performed with the barriers in place.

Vacuum interrupters

The type GMSG circuit breakers use the Siemens family of vacuum interrupters, proven in over 600,000 circuit breakers produced since 1976. The cup-shaped contacts (used for lower interrupting ratings) have chrome-copper arcing rings with a unique radial magnetic field geometry to provide fast interruption with minimal contact erosion. For higher interrupting ratings, axial magnetic field contacts are used to maintain the arc in diffuse mode and minimize contact erosion. The chrome-copper contact material assures lower chopping currents than with designs employing copper-bismuth contacts.



Figure 30: Vacuum interrupter family

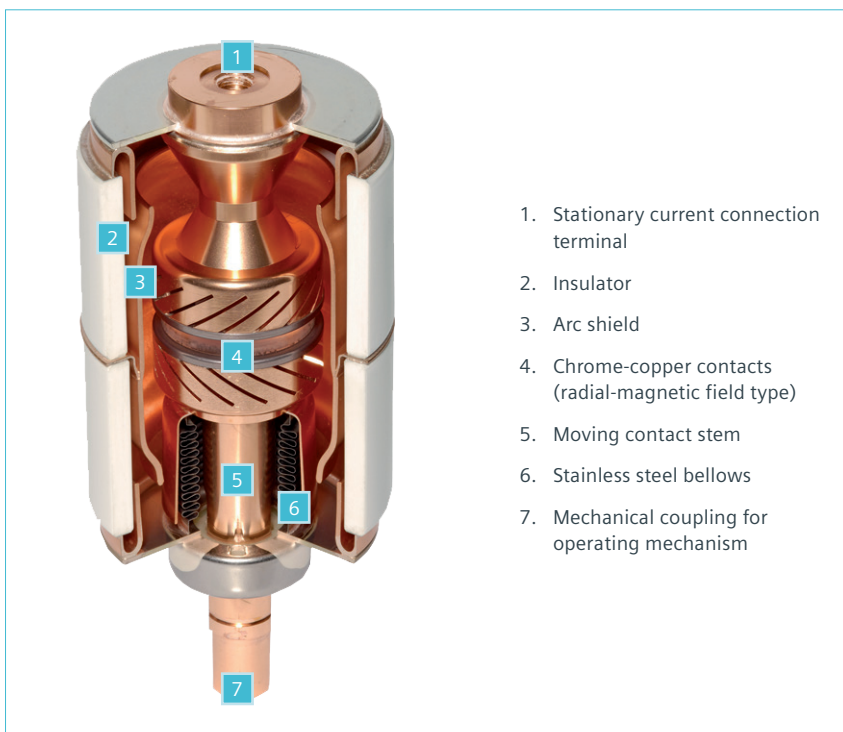

- 1. Stationary current connection terminal
- 2. Insulator
- 3. Arc shield
- 4. Chrome-copper contacts (radial-magnetic field type)
- 5. Moving contact stem
- 6. Stainless steel bellows
- 7. Mechanical coupling for operating mechanism

Figure 31: Vacuum interrupter

Figure 32: Type GMSG circuit breaker key components

1. Closing spring
2. Gearbox
3. Opening spring
4. Push-to-close
5. Auxiliary switch
6. Close coil
7. Trip coil
8. Push-to-trip
9. MOC switch operator
10. Closed circuit breaker interlock
11. Trip-free interlock
12. Spring-charging motor
13. Jack shaft
14. Ground disconnect
15. Operations counter
16. OPEN/CLOSED indicator
17. CHARGED/DISCHARGED indicator
18. Secondary disconnect

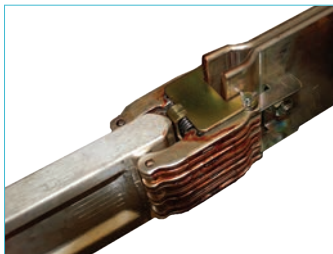
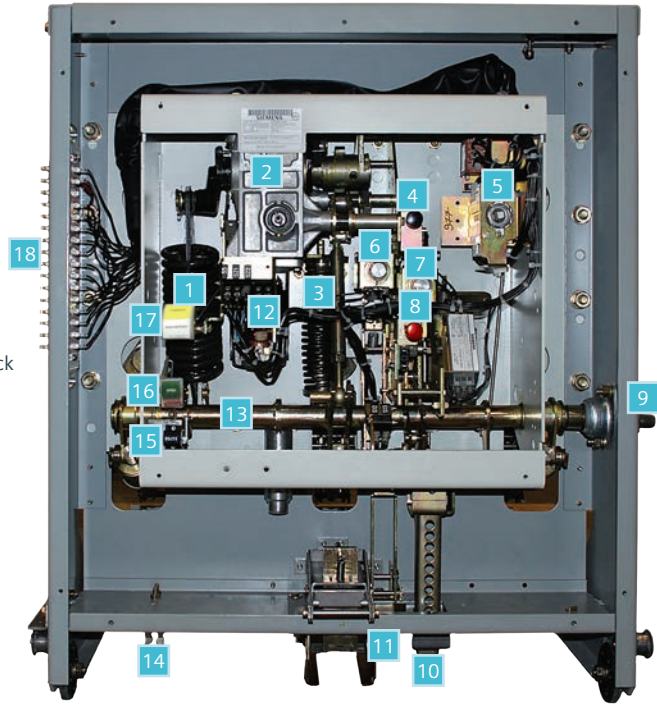

Figure 33: Primary disconnects

“Universal” spare circuit breaker (up to 50 kA)

The physical configuration and interlock logic allow the use of a single circuit breaker to serve as a “universal” spare circuit breaker at an installation site for up to 50 kA. The rating interlock (refer to Figure 14: Circuit breaker cell interior on page 14) logic checks the principal rating characteristics (continuous current, maximum voltage and interrupting current) and allows a circuit breaker to be inserted in a breaker cell provided that the circuit breaker equals or exceeds the ratings required by the cell.

“Universal” spare circuit breaker (63 kA)

The concept described above (for up to 50 kA) also applies for equipment rated 63 kA within the 63 kA rating. Circuit breakers rated 63 kA cannot be used in equipment rated 50 kA or lower.

Generator circuit breakers

Generator circuit breakers are not interchangeable with standard (non-generator) circuit breakers.

Primary disconnects

The primary connection between the circuit breaker and the cubicle is made of multiple sets of silver-plated copper finger contacts that engage with silver-plated copper stationary contacts. The cubicle primary disconnect studs have a tapered leading edge that contributes to smooth racking of the circuit breaker.

The contacts, mounted on the ends of the circuit breaker disconnect stabs, have multiple fingers and are compression spring loaded (one spring per double pair of fingers). This arrangement offers a large number of contact points to ensure proper alignment. The circuit breaker finger assemblies are withdrawn with the circuit breaker and are available for inspection without de-energizing the switchgear main bus.

Non-sliding current transfer

Pioneered by Siemens in the 1970s, the vacuum interrupter movable stem is connected to the lower disconnect stab of the circuit breaker by a reliable flexible connector. This provides a low-resistance current transfer path, not subject to the wear and contamination problems associated with sliding or rolling joints used in some designs.

Secondary disconnects

The circuit breaker-to-cubicle secondary disconnects are designed with sliding fingers. The secondary disconnects are automatically engaged as the circuit breaker is racked into the test position. They remain engaged as the circuit breaker is racked to the connected position. Since the secondary disconnects automatically engage in both the test and connected positions, there is no need to operate a separate linkage for testing.

The secondary disconnects are located on the side of the circuit breaker element where they are shielded from accidental damage. They are of an extremely rugged design, in contrast to other designs that employ light duty electronics-style disconnects, located in hidden or inaccessible locations. Alignment of the disconnects can be visibly observed, if desired, allowing positive verification of secondary integrity. This feature is not possible with designs employing a disconnect underneath or behind the circuit breaker.

Auxiliary switch (circuit breaker mounted)

The auxiliary switch assembly is mounted on the vacuum circuit breaker with contacts for use in the circuit breaker control circuit and as spare contacts for other use. Normally, four auxiliary switch contacts, two NO (52a) and two NC (52b), can be wired out for purchaser use.

Mechanism-operated cell (MOC) switch

When required, 6, 12, 18 or 24 stages of a mechanism-operated cell (MOC) auxiliary switch can be mounted in the circuit breaker cell. This switch is operated by the circuit breaker mechanism, so that the switch contacts change state whenever the circuit breaker is closed or opened. Normally, the MOC switch is operated only when the circuit breaker is in the connected position, but provisions for operation in both the connected and the test positions can be furnished.

All spare MOC contacts are wired to accessible terminal blocks, as shown in Figure 36: MOCs and TOCs (cover removed), for user connections. The lower portion of Figure 36: MOCs and TOCs (cover removed) shows four MOC switches (total 24 stages) plus the MOC operating linkage and four terminal blocks for MOC switch connections.

Truck-operated cell (TOC) switch

When required, 4, 8 or 12 stages of a truck-operated cell (TOC) switch can be mounted in the circuit breaker cell. The TOC switch contacts change state when the circuit breaker moves into or out of the connected position. All spare TOC contacts are wired to accessible terminal blocks, as shown in Figure 36: MOCs and TOCs (cover removed) for user connections.

The upper portion of Figure 36: MOCs and TOCs (cover removed) shows 12 stages of TOC switches plus two terminal blocks for TOC switch connections.



Figure 34: Secondary disconnect cell portion



Figure 35: Secondary disconnect circuit breaker portion



Figure 36: MOCs and TOCs (cover removed)

1. TOC switches and TOC terminal blocks
2. MOC switches and MOC terminal block

Surge limiters

Type 3EJ0 surge limiters are available for use in distribution systems to protect motors, transformers and reactors from the effects of voltage surges associated with circuit breaker operations. These limiters are not designed to protect equipment exposed to lightning surges, for which surge arresters should be applied.

The type 3EJ0 surge limiters prevent the development of excessive overvoltages that can result from multiple re-ignitions or virtual chopping. This is primarily of concern during the starting of motors and switching of some reactive loads.

In general, if the impulse capability (BIL) of the protected equipment matches that of the switchgear, no protection is needed due to the surges produced by the opening of the vacuum breaker. Since dry type transformers and rotating machines are generally of lower BIL, surge protection may be necessary.

For the minimum application recommendations for surge limiters, refer to Table 2: Surge limiter recommendations.

Table 2: Surge limiters

| Protected (load equipment) | | Surge limiters recommended |
|----------------------------|------------------------------|----------------------------|
| Liquid transformers | | No |
| Dry-type transformers | Standard BIL | Yes ¹ |
| | 5 kV 60 kV BIL | No |
| | 7 kV or 15 kV 95 kV BIL | No |
| Motors | Locked rotor current < 600 A | Yes ¹ |
| | Locked rotor current > 600 A | No |
| Reactors | | Yes |
| Capacitors | | No |

Footnote:

¹ Not necessary if surge capacitors or surge arresters are located at transformer or machine terminals.

Figure 37: Type GMSG 50 kA circuit breaker



Figure 38: Type GMSG 63 kA circuit breaker



The advantages inherent in vacuum interruption are summarized as follows:

■ Ideal dielectric

In a vacuum, the dielectric strength across a contact gap recovers very rapidly allowing a small contact separation and an efficient vacuum interrupter design. The vacuum does not interact with the arc or its components.

■ Quiet operation

Interruption of currents by a vacuum circuit breaker is quieter than the loud report that accompanies interruptions in older types of circuit breakers.

■ Low current chopping characteristics

The chrome-copper contact material used in Siemens vacuum interrupters limits chopping currents to a maximum of five amperes. This low value prevents the build-up of unduly high voltages and results in lower stress on the insulation of load equipment.

■ No arc by-products vented to the atmosphere

The sealed vacuum interrupter prevents venting of arc products to the atmosphere and prevents contamination of the contacts by the atmosphere. The metal vapor of the arc quickly recondenses on the surface of the contacts, although a small amount may recondense on the arc chamber wall or arc shield. The recondensing metal vapor acts as a “getter” and recaptures more molecules of certain gases that might be liberated during vaporization. This action tends to improve the vacuum in the interrupter during its operating life.

■ Non-toxic interruption by-products

The interruption process occurs entirely within the sealed vacuum interrupter. Even if a vacuum interrupter is physically broken, the arc products inside the vacuum interrupter are not toxic. In contrast, gas-filled interrupters produce toxic arc by-products, requiring special precautions in the event of a ruptured interrupter housing.

■ Fewer components

The vacuum interrupter pole construction is extremely simple and consists of only seven moving parts within the high voltage area and only two moving parts within the vacuum interrupter chamber. This means greater reliability and less maintenance with vacuum interrupters as compared to the greater number of parts in other types of interrupters, such as gas or oil.

■ Long vacuum interrupter life

Due to the careful selection of components, the vacuum interrupter has an expected long service life. The chrome-copper contacts allow efficient interruption of both diffused and contracted arcs with very little contact erosion.

■ Immunity to environment

The capability of the vacuum interrupter to interrupt current or to withstand voltage is not directly affected by conditions external to the vacuum interrupter. High or low altitudes, hot or cold temperatures, moist or dry conditions, or heavy dust conditions do not affect the conditions internal to the vacuum interrupter. Conditions external to the vacuum interrupter, however, could affect the overall system operation and should be considered in the specifications.

■ Low maintenance

Vacuum interrupter maintenance typically requires wiping dust or other atmospheric elements from the exterior, visually checking the contact wear indicator and periodic dielectric testing to confirm vacuum integrity.

■ Lower force requirements

The vacuum interrupter has a very low moving mass compared to that found in other interrupters. This allows for a smaller, more compact stored-energy operator leading to the long life and low maintenance of the circuit breaker.

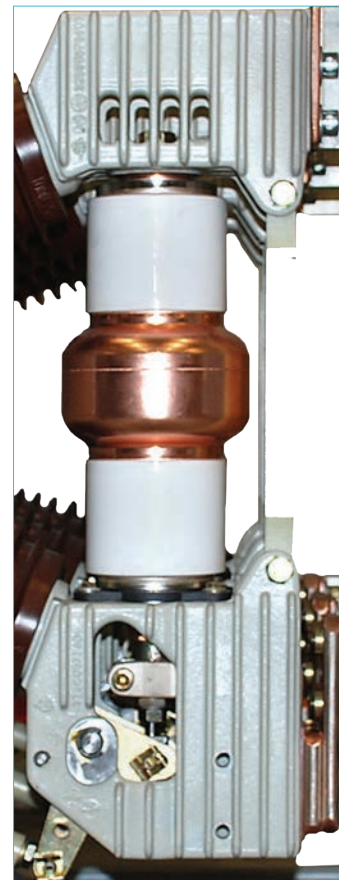

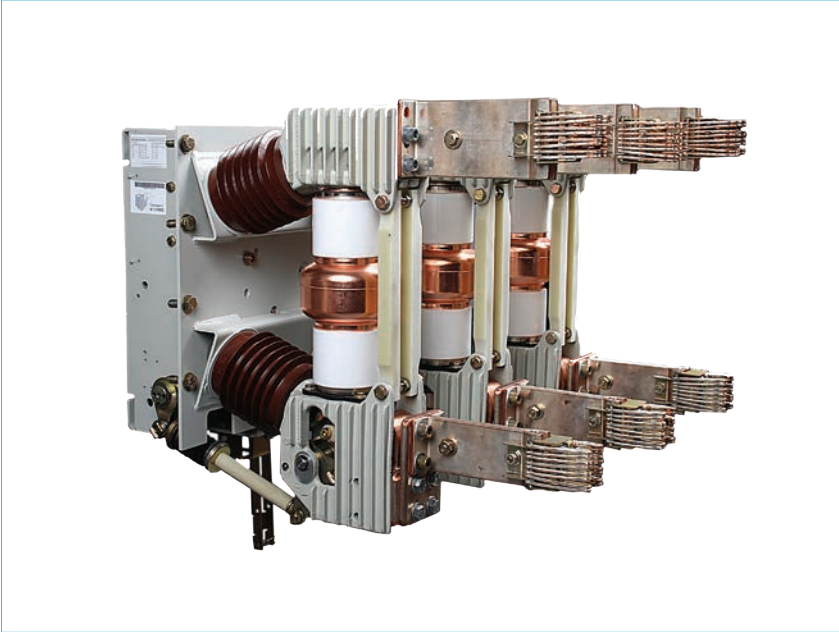

Figure 39: Type 3AH3 operating mechanism

Siemens vacuum heritage

Type GMSG vacuum circuit breakers take full advantage of Siemens' long history with vacuum interrupters for power applications. While early work was carried out in the 1920s, a successful vacuum interrupter could not be perfected until the high vacuum pump became available in the 1960s. Siemens began to focus development efforts in 1969, culminating with the introduction of the type 3AF circuit breaker in 1976. The knowledge gained over years of application of this technology in the types 3AF and 3AH circuit breakers is now available in the type GMSG design.

Vacuum interrupter principles

With Siemens type GMSG vacuum circuit breakers, the chopping currents are held to five amperes or less. This is low enough to prevent the build-up of unduly high voltages that may occur on switching of inductive circuits. The chrome-copper contact material keeps overvoltages to a minimum so special surge protection is not required in most applications.

When the contacts open, the current to be interrupted initiates a metal vapor arc discharge and current continues flowing through this plasma until the next current zero.

The arc is extinguished near the current zero and the conductive metal vapor recondenses on the contact surfaces and the arc chamber wall or arc shield within a matter of microseconds. As a result, the dielectric strength of the break recovers very rapidly and contact erosion is almost negligible.

The arc drawn in the vacuum interrupter is not cooled. The metal vapor plasma is highly conductive and the resulting arc voltage is only 20 to 200 volts. This low arc voltage, combined with very short arcing times, produces only a very small arc energy in the vacuum interrupter, accounting for the long electrical life expectancy of the Siemens vacuum interrupter.

There are two types of arc shapes. Up to approximately 10 kA, the arc remains diffused. It takes the form of a vapor discharge and covers the entire contact surface. Diffused arcs are easily interrupted.

Radial magnetic field design vacuum interrupters (refer to Figure 40 on page 29, A) are used for lower interrupting ratings. In radial magnetic field interrupters, when the arc current exceeds about 10 kA, the arc is constricted considerably by its own magnetic field and contracts essentially to a point arc. If the contracted arc is allowed to remain stationary, it overheats the contact at the arc roots to the point where molten metal vapor does not allow the dielectric to rebuild during the current zero and large magnitude currents cannot be interrupted. To overcome this, the contacts are designed in a cup shape with oblique slots, so that a self-generated field causes the arc to travel around the contacts. This prevents localized overheating when interrupting large magnitudes of short circuit current.

For high interrupting ratings, axial magnetic field design (refer to Figure 40 on page 29, B) is employed. In this configuration, the current flow creates a magnetic field along the longitudinal axis of the vacuum interrupter. This field prevents constriction of the arc and this forces the arc to remain in diffuse mode. Since the arc remains in diffuse mode, localized overheating is avoided and contact erosion is held to low levels.

A. Arc formation with RMF contacts
(high-speed photographs (exposure time 13 μ s))

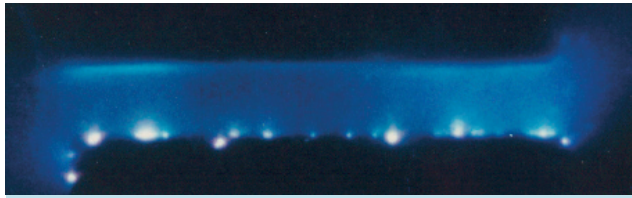

Diffuse arc prior to current zero ($i = 2$ kA); cathode at bottom



Constricted arc ($i = 40$ kA)

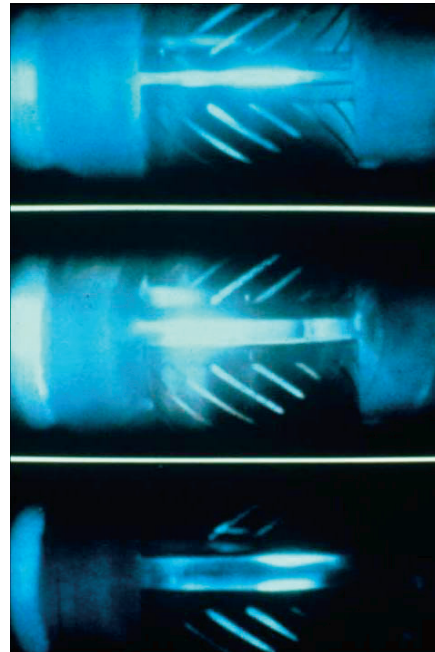

Arc movement – radial magnetic-field contacts

- Constricted arc moves around contacts
- Up to four rotations per interruption
- Prolongs contact life by distributing heat

B. Arc formation with AMF contacts (high-speed photographs (exposure time 13 μ s); cathode at bottom)

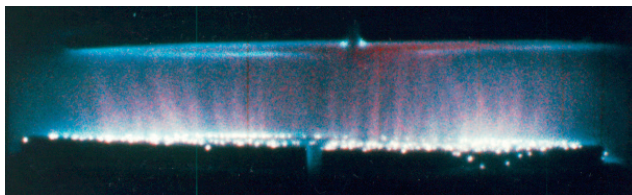

Diffuse arc prior to current zero ($i = 10$ kA)

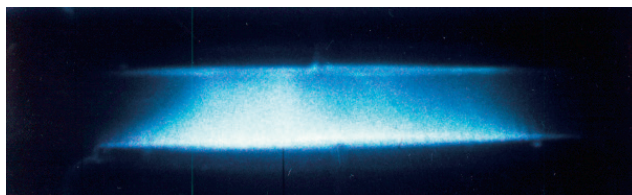

Diffuse high-current discharge ($i = 60$ kA)

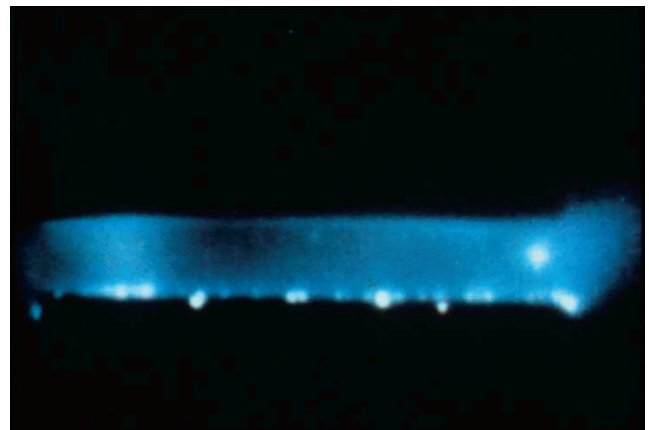

Typical diffuse arc during load current interruption

Figure 40: Radial- and axial-field arcing

Generator vacuum circuit breakers

Type GMSG-GCB generator circuit breakers

Drawout type generator circuit breakers for use in type GM-SG metal-clad switchgear are available. These circuit breakers are derived from the same type 3AH3 family of circuit breaker operating mechanisms as our standard non-generator circuit breakers. The basic design of the circuit breakers is the same, making maintenance and operation of the generator circuit breakers the same as for non-generator circuit breakers. This means that there is no incremental or additional training needed for your maintenance or operational personnel. The type GMSG-GCB generator circuit breakers exploit the long history of successful service provided by the entire type 3A (including types 3AF and 3AH operators) family of vacuum circuit breakers.

These generator circuit breakers fully conform to the requirements for generator circuit breakers as specified in IEEE Std C37.013™, International Standard – High-voltage switchgear and controlgear – Part 37- 013: Alternating-current generator circuit breakers.

In our discussion of generator circuit breakers, the term “distribution circuit breakers” will be used to refer to ordinary (non-generator) circuit breakers conforming to IEEE Stds. C37.04, C37.06 and C37.09.

The ratings for the type GMSG-GCB generator circuit breakers are listed on page 39.

Generator application differences

What makes the application to a generator different than ordinary distribution circuit breaker applications to feeders, motors, main circuit breakers or other non-generator circuits? Several aspects differ considerably, including:

- Very high X/R ratio
- Higher momentary (close and latch) currents
- Faster rate of rise of transient recovery voltage (TRV)
- Delayed current zeros
- No reclosing duty
- Out-of-phase switching duty.

Very high X/R ratio

The standards for distribution circuit breakers are based on a circuit X/R ratio of 17 (at 60 Hz), which results in a 45 ms time constant of decay of the dc component of a short-circuit current. This determines the amount of dc current that is added to the ac component of the short-circuit current during type or design testing. A circuit breaker with rated interrupting time of 50 ms (historically termed a “three-cycle breaker”) requires a %dc component of 47 percent (at contact part), which is equivalent to the historic “S-factor” of 1.2. The S-factor was defined in IEEE Std C37.04-1979 as the ratio of the total rms asymmetrical current to the symmetrical current. While the S-factor is no longer in the standards, it provides a simple way to grasp the difference between a generator circuit breaker and a distribution circuit breaker.

In contrast, IEEE Std C37.013 specifies that tests be conducted based on an X/R ratio of 50 (at 60 Hz), which corresponds to a time constant of decay of the dc component of the short-circuit current of 133 ms.

This results in a much higher dc current at a given contact-part time than for a distribution circuit breaker. Using the example of a generator circuit breaker with rated interrupting time of 50 ms, the %dc component at contact part would be 78 percent and the required S-factor would be 1.48.

If a circuit breaker rated 50 kA symmetrical, the corresponding required asymmetrical interrupting capability would be $50 \times 1.2 = 60$ kA for the distribution circuit breaker, and $50 \times 1.48 = 72$ kA for the generator circuit breaker. This demonstrates that a generator circuit breaker is subjected to much heavier interrupting requirements than a distribution circuit breaker.

Higher momentary duty

The higher X/R ratio of a generator application also affects the required peak withstand capability of the circuit breaker. This is due to the much slower rate of decay of the dc component of the short-circuit current. For a distribution circuit breaker, the peak withstand current rating is 260 percent of the symmetrical interrupting rating of the circuit breaker. For the generator circuit breaker, the peak withstand current rating is 274 percent of the symmetrical interrupting rating of the circuit breaker. The peak withstand current is related to the historic concept of a momentary current, sometimes referred to as "bus bracing," and is the current that the circuit breaker must withstand during a fault closing operation, as well as the current that the switchgear must withstand without damage. This current is also commonly called the closing and latching current. The difference between 274 percent and 260 percent may seem slight, but it results in a mechanical duty over 10 percent higher on a generator circuit breaker than on a distribution circuit breaker.

Faster rate of TRV

TRV is the result of interrupting current flow in a load circuit. When a short-circuit current is interrupted, the current and voltage are almost 90 degrees out-of-phase. Thus, when the current goes through zero, the system voltage is nearly at a maximum instantaneous value. When the interruption occurs, the capacitance of the load circuit is charged to the maximum voltage, and electrical energy stored in the capacitance begins to transfer to magnetic energy stored in the inductances.

In a generator circuit breaker application, the generator (or the step-up transformer if the fault source is from the generator) is a highly inductive component with very low capacitance. As a result, the natural frequency of this circuit (consisting of high inductance and low capacitance) is very high.

Therefore, the TRV produced by the load circuit upon interruption of a short-circuit current has a very high rate of rise, much higher than that of a distribution circuit.

For comparison, for a distribution circuit breaker rated 15 kV, the rate of rise of TRV (RRRV) for short-circuits is 0.39 kV/ μ s for a traditional indoor circuit breaker (now termed a class S1 circuit breaker in IEEE Std C37.06-2009). In contrast, the RRRV of a generator circuit breaker, in accordance with IEEE Std C37.013 for a system source fault is 4.0 kV/ μ s, for a machine of 101-200 MVA.

While this difference is severe, the vacuum circuit breaker is ideally suited to fast RRRV applications. The dielectric strength between the contacts recovers extremely rapidly following interruption.

Delayed current zeros

Generator applications may be subject to a phenomenon frequently referred to as "missing current zeros," but which is properly termed "delayed current zeros."

Generally, it is assumed that the symmetrical current during a short-circuit has a constant magnitude and does not decline with the duration of the fault. Of course, the dc component of a short circuit does decline, but the ac component (the symmetrical current) is considered constant.

However, in a generator application, it may be that the symmetrical current magnitude does not remain constant. It may decline as the generator slows down during the fault. If the time constant of decay of the ac component (the symmetrical current) is faster than the time constant of decay of the dc component, then the summation of the ac and dc components will move the resultant current away from the zero axis.

For this reason, IEEE Std C37.013 requires that tests be conducted in which the test circuit is intentionally adjusted to delay the first current zero for an extended time.

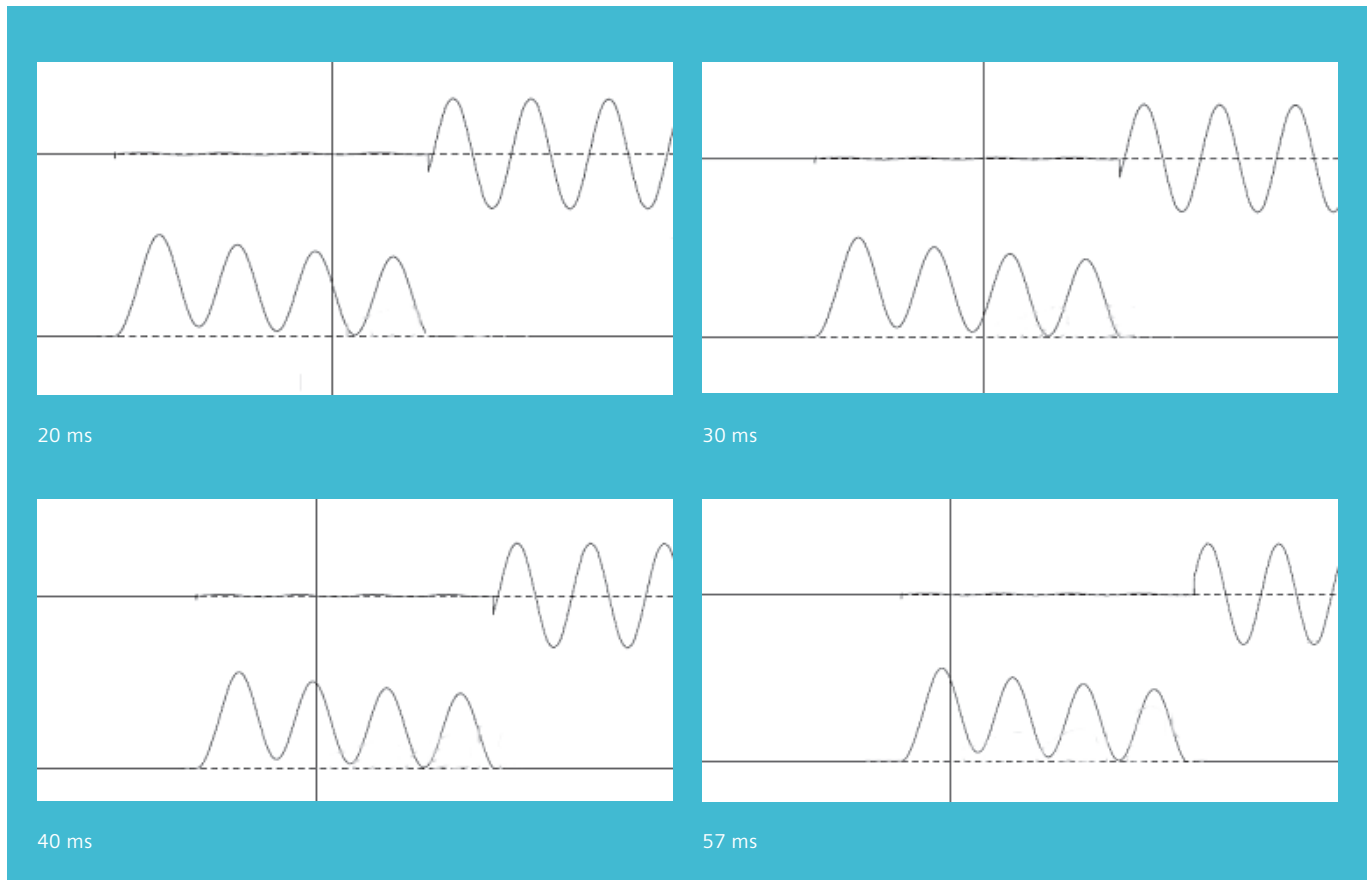

Figure 41: Delayed current zero tests example

Figure 41: Delayed current zero tests example on page 32 shows test currents in which the first current zero was intentionally delayed in the power test laboratory. The delay from circuit breaker contact parting to first current zero was delayed progressively from about 20 ms to over 57 ms in the tests shown. Further delay was not possible due to limitation in the laboratory.

No reclosing duty

One difference between a generator circuit breaker and a distribution circuit breaker is actually less severe. In a generator application, reclosing is never used. While the circuit breaker could probably deal with the duty, the need to establish synchronism between machine and system makes reclosing impractical.

Out-of-phase switching duty

Generator applications also have to consider the potential for the circuit breaker to interrupt short-circuit currents when the generator is out-of-phase with the power system. During such conditions, the voltage across the open contacts is much higher than during normal interruptions. In the worst case of machine and system 180 degrees out-of-phase, the voltage across the contacts would be twice that of normal interruptions. However, IEEE Std C37.013 considers 90 degrees to be the upper limit to avoid damage to the machine. IEEE considers out-of-phase switching as an optional capability. The type GMSG-GCB generator circuit breakers are tested for out-of-phase switching capability.

Standards

Requirements for generator circuit breakers are given in IEEE Std C37.013. Originally created to cover circuit breakers for machines of 100 MVA and higher, it was amended in 2007 to extend requirements to encompass machines as small as 10 MVA. The standards for distribution circuit breakers (including IEEE Stds C37.04, C37.06, C37.09 and C37.010) do not apply to generator circuit breakers.

In the case of a drawout type circuit breaker for use in metal-clad switchgear, the circuit breaker design, construction and type testing must be coordinated with IEEE Std C37.20.2. In particular, drawout interlocks, temperature rise and other aspects peculiar to metal-clad switchgear must be met.

Some may wonder why it was necessary to create new standards for generator circuit breakers. After all, the standards for distribution circuit breakers have served us well for many decades in such applications. This is certainly a reasonable statement, as distribution circuit breakers have been used in generator applications for over 50 years with good success. However, the use of distributed generation is increasing, and the size of the machines involved is also increasing. In addition, prime movers (such as aero-derivative gas turbines) with relatively low rotating inertia are now common.

A low inertia machine introduces more significant concerns with respect to delayed current zeros.

In addition, the testing protocols in the standards have improved dramatically in recent years, in part due to increased data gathering capabilities in the power test laboratories, as well as due to the improved ability of the laboratories to control the point-on-wave at contact parting. These improvements have made it possible to explore the capabilities of circuit breakers to a level never imagined some decades ago.

Design testing considerations

The short-circuit tests required for generator circuit breakers are extreme and only a few laboratories can conduct such tests. Siemens insists on testing our generator circuit breakers using direct power tests, in which the short-circuit current and recovery voltage are both supplied by the short-circuit generator. This limits the number of power laboratories in the world capable of such tests to a mere handful.

One of the major difficulties that laboratories have is the high RRRV requirements for the TRV during tests. Most laboratories have a relatively high amount of stray capacitance inherent in the laboratory itself, making it impossible for them to produce RRRV values in the range of 3.0 kV/μs to 4.5 kV/μs. Siemens tests have been conducted with direct power tests on each of the ratings available in the type GMSG-GCB circuit breakers.

In addition, all tests have been conducted as three-phase tests, except for out-of-phase and delayed current zero tests, where laboratory limits force the tests to be made on a single-phase basis. Unlike some other companies, Siemens does not use synthetic test methods, in which short-circuit current is provided by the generator, but recovery voltage is provided by a separate low-power, high-voltage source. While the standards allow synthetic testing, Siemens prefers direct testing.

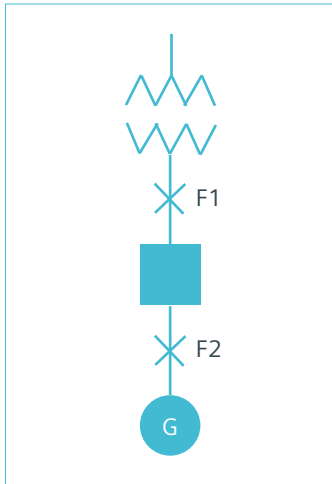

Figure 42: Simplified one-line diagram

Rating structure

One of the confusing aspects of a generator application is that the generator circuit breaker has different ratings for a system-source fault than for a generator-source fault. Consider, for example, the simplified one-line diagram in Figure 42.

For a fault at F1 in the diagram, the fault receives current both from the step-up transformer and from the generator.

However, only the current from the generator passes through the generator circuit breaker. The generator has a relatively low short-circuit capability and a relatively high sub-transient reactance, and thus the short-circuit current through the generator circuit breaker with fault at location F1 is relatively low.

In contrast, for a fault at location F2, the total current into the fault is the same but this time, only the contribution from the step-up transformer passes through the generator circuit breaker. The short-circuit capability for the system (transformer) source fault is very high since the transformer is normally connected to a robust high voltage system. In addition, the transformer impedance is relatively low compared to the sub-transient reactance of a generator. The result is that the short-circuit current originating from the system (the transformer) is usually at least twice the short-circuit current that can originate from the generator.

This explains why generator circuit breakers have a short-circuit interrupting rating that is based on a system-source fault condition. This rating is used as the nominal rating of the circuit breaker. Standards require the generator-source interrupting rating to be 50 percent of the system-source rating.

Mechanical endurance

The mechanical endurance required by IEEE Std C37.013, clause 4.108 is a mere 1,000 operations. The type GMSG-GCB generator circuit breaker operators share the design heritage of the rest of the type 3AH3 operator family, and have been tested to demonstrate mechanical endurance of 10,000 operations, exceeding the endurance required by the standards for generator circuit breakers.

Technical data

| Control voltages, ANSI/IEEE C37.06-2009 | | | Close coil | Trip coil | Spring charging motor | |
|---|---------|---------|----------------|-------------------|-------------------------|----------|
| Nominal | Range | | | | A | Charging |
| | Close | Trip | A ¹ | A ^{1,3} | Run (Avg.) ¹ | Seconds |
| 24 Vdc | 19-28 | 14-28 | 15.0 | 15/---- | ---- | ---- |
| 48 Vdc | 36-56 | 28-56 | 11.4 | 11.4/30 | 8 | 10 |
| 125 Vdc | 100-140 | 70-140 | 2.1 | 4.8/7.4 | 4 | 10 |
| 250 Vdc | 200-280 | 140-280 | 2.1 | 4.2/9.6 | 2 | 10 |
| 120 Vac | 104-127 | 104-127 | 2.0 | ---- ² | 6 | 10 |
| 240 Vac | 208-254 | 208-254 | 2.0 | ---- ² | 3 | 10 |

Table 3: Type GMSG circuit breaker control data⁴

Footnotes:

- Current at nominal voltage.
- Capacitor trip.
- Value preceding slash (/) is the current for the standard trip coil with standard rating interrupting time. Value following (/) is current for optional trip coil with three-cycle interrupting time.
- means this selection is not available at this voltage.

| Type switch | Continuous current (A) | Control circuit voltage | | | | |
|-----------------|------------------------|-------------------------|---------|--------------------|---------|---------|
| | | 120 Vac | 240 Vac | 48 Vdc | 125 Vdc | 250 Vdc |
| Circuit breaker | 10 | 10 | 5 | 10/30 ² | 5 | 3 |
| TOC | 15 | 15 | 10 | 0.5 | 0.5 | 0.2 |
| MOC | 20 | 15 | 10 | 10 | 10 | 5 |

Table 4: Interrupting capacity auxiliary switch contacts¹

Footnotes:

- All switch contacts are non-convertible.
- Two contacts in series.

| | | |
|--|-------------------------------------|---------|
| Spring charging time | | ≤ 10 s |
| Close time from energizing close coil at rated control voltage to contact touch (last pole) | | ≤ 65 ms |
| Opening time from energization trip coil at rated control voltage to contact part (last pole), not including arcing time | 5-cycle interrupting time (83 ms) | ≤ 56 ms |
| | 3.5-cycle interrupting time (58 ms) | ≤ 43 ms |
| | 3-cycle interrupting time (50 ms) | ≤ 33 ms |

Table 5: Circuit breaker operating times (type 3AH3 operator)

Table 6: Type GMSG circuit breaker ratings (new "constant kA" ratings basis)

| Circuit breaker type ¹ | Maximum design voltage (V) ² | Voltage range factor (K) ³ | Withstand voltage levels | | Continuous current ⁴ | Short-circuit (I) ^{5, 6} | |
|-----------------------------------|---|---------------------------------------|--------------------------------------|---------------------------------|--|-----------------------------------|------------------------|
| | kV rms | | Power frequency kV rms | Lightning impulse (BIL) kV peak | A rms | kA rms sym | |
| 5-GMSG-40-xxxx-104 | 4.76 | 1.0 | 19 | 60 | 1,200, 2,000, 3,000, 4,000FC | 40 | |
| 5-GMSG-50-xxxx-130 | 4.76 | 1.0 | 19 | 60 | 1,200, 2,000, 3,000, 4,000FC | 50 | |
| 5-GMSG-63-xxxx-164 | 4.76 | 1.0 | 19 | 60 | 1,200, 2,000, 3,000, 4,000FC | 63 | |
| 7-GMSG-40-xxxx-104 | 8.25 | 1.0 | 36 | 95 | 1,200, 2,000, 3,000, 4,000FC | 40 | |
| 15-GMSG-25-xxxx-65 | 15.0 | 1.0 | 36 | 95 | 1,200, 2,000 | 25 | |
| 15-GMSG-40-xxxx-104 | 15.0 | 1.0 | 36 | 95 | 1,200, 2,000, 3,000, 4,000FC | 40 | |
| 15-GMSG-50-xxxx-130 | 15.0 | 1.0 | 36 | 95 | 1,200, 2,000, 3,000, 4,000FC | 50 | |
| 15-GMSG-63-xxxx-164 | 15.0 | 1.0 | 36 | 95 | 1,200, 2,000, 3,000, 4,000FC | 63 | |
| Circuit breaker type ¹ | Interrupting time ⁷ | Permissible tripping delay (Y) | Maximum symmetrical interrupting (I) | % dc component | Short-time current (I) (three seconds) | Closing and latching (momentary) | |
| | ms/cycles | Sec | kA rms sym | % | kA rms | Asymmetrical (1.55 x I) kA rms | Peak (2.6 x I) kA peak |
| 5-GMSG-40-xxxx-104 | 83/5 | 2 | 40 | 47 | 40 | 62 | 104 |
| 5-GMSG-50-xxxx-130 | 83/5 | 2 | 50 | 47 | 50 | 78 | 130 |
| 5-GMSG-63-xxxx-164 | 83/5 | 2 | 63 | 47 | 63 | 98 | 164 |
| 7-GMSG-40-xxxx-104 | 83/5 | 2 | 40 | 47 | 40 | 62 | 104 |
| 15-GMSG-25-xxxx-65 | 83/5 | 2 | 25 | 47 | 25 | 39 | 65 |
| 15-GMSG-40-xxxx-104 | 83/5 | 2 | 40 | 47 | 40 | 62 | 104 |
| 15-GMSG-50-xxxx-130 | 83/5 | 2 | 50 | 47 | 50 | 78 | 130 |
| 15-GMSG-63-xxxx-164 | 83/5 | 2 | 63 | 47 | 63 | 98 | 164 |

Footnotes:

1. "xxxx" in type designation refers to the continuous current rating 1,200 A, 2,000 A or 3,000 A, as appropriate. The 4,000 A fan-cooled rating is achieved using a 3,000 A circuit breaker, in combination with fan cooling as indicated in Footnote 4.
2. Maximum design voltage for which the circuit breaker is designed and the upper limit for operation.
3. K is listed for information purposes only. For circuit breakers rated on a "constant kA" ratings basis, the voltage range factor is 1.0.
4. 4,000FC indicates that fan cooling is included in the switchgear structure (indoor only) for this rating. Consult factory for availability of 4,000 A rating in Shelter-Clad and Shelter-Clad+ outdoor switchgear. 4,000 A rating is not available in OGM-SG non-walkin outdoor switchgear. When furnished, 4,000 A main bus is self-cooled.
5. All values apply to polyphase and line-to-line faults.
6. Standard duty cycle is O - 0.3 s - CO - 3 min. - CO.
7. Standard rating interrupting time is five-cycles (83 ms). Optional rated interrupting time of three-cycles (50 ms) is available (except with 24 Vdc tripping).

These ratings are in accordance with:

- ANSI/IEEE C37.04 Standard Rating Structure for AC High-Voltage Circuit Breakers
- ANSI/IEEE C37.06 AC High-Voltage Circuit Breakers Rated on a Symmetrical Current Basis - Preferred Ratings and Related Required Capabilities for Voltages Above 1,000 Volts
- ANSI/IEEE C37.09 Standard Test Procedure for AC High-Voltage Circuit Breakers Rated on a Symmetrical Current Basis
- ANSI/IEEE C37.010 Application Guide for AC High-Voltage Circuit Breakers Rated on a Symmetrical Current Basis.

Table 7: Type GMSG circuit breaker ratings (historic "constant MVA" ratings basis)

| Circuit breaker type ¹ | Nominal voltage class | Nominal three-phase MVA class ² | Maximum design voltage (V) ³ | Continuous current ⁴ | | Voltage range factor (K) ⁵ | Withstand voltage levels | |
|-----------------------------------|--|--|---|---|--------------------------------|---------------------------------------|---|--|
| | kV | MVA | kV rms | A rms | | ---- | Power frequency kV rms | Lightning impulse (BIL) kV peak |
| 5-GMSG-250-xxxx-97 | 4.16 | 250 | 4.76 | 1,200, 2,000 | | 1.24 | 19 | 60 |
| 5-GMSG-350-xxxx-132 | 4.16 | 350 | 4.76 | 1,200, 2,000, 3,000, 4,000FC | | 1.19 | 19 | 60 |
| 7-GMSG-500-xxxx-111 | 7.2 | 500 | 8.25 | 1,200, 2,000, 3,000, 4,000FC | | 1.25 | 36 | 95 |
| 15-GMSG-500-xxxx-62 | 13.8 | 500 | 15.0 | 1,200, 2,000, 3,000, 4,000FC | | 1.30 | 36 | 95 |
| 15-GMSG-750-xxxx-97 | 13.8 | 750 | 15.0 | 1,200, 2,000, 3,000, 4,000FC | | 1.30 | 36 | 95 |
| 15-GMSG-1000-xxxx-130 | 13.8 | 1,000 | 15.0 | 1,200, 2,000, 3,000, 4,000FC | | 1.30 | 36 | 95 |
| Circuit breaker type ¹ | Short-circuit (at rated maximum design voltage) (I) ^{6,8} | Short-time current (K x I) (three seconds) | Rated maximum design voltage (V) divided by K (= V/K) | Maximum symmetrical interrupting (K x I) ⁹ | Permissible tripping delay (Y) | Interrupting time ¹⁰ | Closing and latching (momentary) | |
| | kA rms sym | kA rms | kV rms | kA rms sym | Sec | ms/cycles | Asymmetrical (1.6 x K x I) ¹¹ kA rms | Peak (2.7 x K x I) ¹¹ kA peak |
| 5-GMSG-250-xxxx-97 | 29 | 36 | 3.85 | 36 | 2 | 83/5 | 58 | 97 |
| 5-GMSG-350-xxxx-132 | 41 | 49 | 4.0 | 49 | 2 | 83/5 | 78 | 132 |
| 7-GMSG-500-xxxx-111 | 33 | 41 | 6.6 | 41 | 2 | 83/5 | 66 | 111 |
| 15-GMSG-500-xxxx-62 | 18 | 23 | 11.5 | 23 | 2 | 83/5 | 37 | 62 |
| 15-GMSG-750-xxxx-97 | 28 | 36 | 11.5 | 36 | 2 | 83/5 | 58 | 97 |
| 15-GMSG-1000-xxxx-130 | 37 | 48 | 11.5 | 48 | 2 | 83/5 | 77 | 130 |

For footnotes, please refer to page 38.

These ratings are in accordance with:

- ANSI/IEEE C37.04 Standard Rating Structure for AC High-Voltage Circuit Breakers Rated on a Symmetrical Current Basis
- ANSI C37.06 AC High-Voltage Circuit Breakers Rated on a Symmetrical Current Basis - Preferred Ratings and Related Required Capabilities
- ANSI/IEEE C37.09 Standard Test Procedure for AC High-Voltage Circuit Breakers Rated on a Symmetrical Current Basis
- ANSI/IEEE C37.010 Application Guide for AC High-Voltage Circuit Breakers Rated on a Symmetrical Current Basis.



Type GMSG vacuum circuit breaker

Footnotes:

1. "xxxx" in type designation refers to the continuous current rating 1,200 A, 2,000 A or 3,000 A, as appropriate. The 4,000 A fan-cooled rating is achieved using a 3,000 A circuit breaker, in combination with fan cooling as indicated in Footnote 4.
2. "Nominal three-phase MVA class" is included for reference only. This information is not listed in ANSI C37.06-1987.
3. Maximum design voltage for which the circuit breaker is designed and the upper limit for operation.
4. 4,000FC indicates that fan cooling is included in the switchgear structure for this rating (indoor only). Consult factory for availability of 4,000 A rating in Shelter-Clad or Shelter-Clad+ outdoor switchgear. 4,000 A rating is not available in OGM-SG non-walkin outdoor switchgear. When furnished, 4,000 A main bus is self-cooled.
5. K is the ratio of the rated maximum design voltage to the lower limit of the range of operating voltage in which the required symmetrical and asymmetrical interrupting capabilities vary in inverse proportion to the operating voltage.
6. The following formula shall be used to obtain the required symmetrical interrupting capability of a circuit breaker at an operating voltage between 1/K times rated maximum design voltage and rated maximum design voltage: Required symmetrical interrupting capability = rated short-circuit current (I) x [(rated maximum design voltage)/(operating voltage)]. For operating voltages below 1/K times maximum design voltage, the required symmetrical interrupting capability of the circuit breaker shall be equal to K times rated short-circuit current.
7. Within the limitations stated in ANSI/IEEE C37.04-1979, all values apply to polyphase and line-to-line faults. For single phase-to-ground faults, the specific conditions stated in clause 5.10.2.3 of ANSI/IEEE C37.04-1979 apply.
8. Standard duty cycle is O - 15s - CO.
9. Current values in this row are not to be exceeded even for operating voltage below 1/K times rated maximum design voltage. For operating voltages between rated maximum design voltage and 1/K times rated maximum design voltage, follow Footnote 5.
10. Standard rating interrupting time is five-cycles (83 ms). Optional rated interrupting time of three-cycles (50 ms) is available (except with 24 Vdc tripping).
11. Current values in this row are independent of operating voltage up to and including rated maximum voltage.

Table 8: Type GMSG-GCB circuit breaker ratings

| Rated values and related capabilities | IEEE Std C37.013 clause | Units | Circuit breaker type ³ | | |
|--|--|---|--|---|---|
| | | | 15-GMSG-GCB-40-XXXX-110 | 15-GMSG-GCB-50-XXXX-137 | 15-GMSG-GCB-63-XXXX-173 |
| Rated maximum voltage (V) | 5.1 | kV | 15.0 | 15.0 | 15.0 |
| Power frequency | 5.2 | Hz | 60 | 60 | 60 |
| Rated continuous current | 5.3 | A | 1,200, 2,000, 3,000, 4,000FC | 1,200, 2,000, 3,000, 4,000FC | 1,200, 2,000, 3,000, 4,000FC |
| Rated dielectric strength (withstand voltage) 1. Power frequency, one minute 2. Impulse | 5.4.2 C37.013a, Table 4 | kV kV peak | 38 95 | 38 95 | 38 95 |
| Rated short-circuit duty cycle | 5.5 | | CO-30 min-CO | CO-30 min-CO | CO-30 min-CO |
| Rated interrupting time ^{1,2} | 5.6 | ms | < 80 ms | < 80 ms | < 80 ms |
| Rated short-circuit current 1. System source (100%) (I) 2. Generator source (50%) | 5.8.1 5.8.2.3 | kA sym kA sym | 40 20 | 50 25 | 63 31.5 |
| dc component | | % | 75 | 64 | 61 |
| Asymmetry ratio (historical "S" factor) | | ---- | 1.46 | 1.35 | 1.32 |
| Asymmetrical interrupting (ref) | | kA rms | 57.9 | 67.5 | 83 |
| Delayed current zero capability | | ms | 40 | 30 | 30 |
| Close and latch capability (274% I) | | kA peak | 110 | 137 | 173 |
| Short-time current carrying capability (100% I) | 5.8.2.7 | kA sym | 40 | 50 | 63 |
| Short-time current duration | 5.8.2.7 | s | 3 | 3 | 3 |
| Transient recovery voltage (TRV) rating System source 1. E ₂ peak voltage 2. RRRV (TRV rate) 3. T ₂ time-to-peak Generator source 1. E ₂ crest voltage 2. RRRV (TRV rate) 3. T ₂ time-to-peak Out-of-phase switching 1. E ₂ crest voltage 2. RRRV (TRV rate) 3. T ₂ time-to-peak | 5.9 C37.013a, Table 5 C37.013a, Table 6 C37.013a, Table 9 | kV kV / μs μs kV kV / μs μs kV kV / μs μs | 27.6 (1.84 V) 3.5 9.3 (0.62 V) 27.6 (1.84 V) 1.6 20.25 (1.35 V) 39.0 (2.6 V) 3.3 13.4 (0.89 V) | 27.6 (1.84 V) 4.5 7.2 (0.48 V) 27.6 (1.84 V) 1.8 18.0 (1.20 V) 39.0 (2.6 V) 4.1 10.8 (0.72 V) | 27.6 (1.84 V) 4.5 7.2 (0.48 V) 27.6 (1.84 V) 1.8 18.0 (1.20 V) 39.0 (2.6 V) 4.1 10.8 (0.72 V) |
| Rated load-current switching capability | 5.10 | A | 1,200, 2,000, 3,000 | 1,200, 2,000, 3,000, 4,000 | 1,200, 2,000, 3,000, 4,000 |
| Out-of-phase current switching capability | 5.12 | kA | 20 | 25 | 31.5 |
| Mechanical endurance | | operations | 10,000 | 10,000 | 10,000 |

Footnotes:

¹ Interrupting time is based on the first current zero occurring no later than 66 ms after fault initiation, for example, %dc component <100.

² Interrupting time of 50 ms available, provided that the first current zero occurs no later than 50 ms after fault initiation.

³ "xxxx" in type designation refers to the continuous current rating 1,200 A, 2,000 A or 3,000 A, as appropriate. The 4,000 A fan-cooled rating is achieved using a 3,000 A circuit breaker in combination with fan cooling in the switchgear structure (indoor only).



Figure 43: Current transformer

Table 9: Current transformers^{1,4}

| Ratio | 60 Hz metering accuracy at burden | | | | Relay class |
|---|-----------------------------------|------|------------------|------|-------------|
| | B0.1 | B0.5 | B1.0 | B2.0 | |
| Type MD toroidal standard accuracy ⁴ | | | | | |
| 100:5 | 2.4 ² | ---- | ---- | ---- | C 15 |
| 150:5 | 0.6 | 2.4 | ---- | ---- | C 20 |
| 200:5 | 0.6 | 1.2 | ---- | ---- | C 25 |
| 250:5 | 0.6 | 1.2 | ---- | ---- | C 35 |
| 300:5 | 0.6 | 1.2 | 2.4 | ---- | C 40 |
| 400:5 | 0.3 | 0.6 | 2.4 ² | ---- | C 60 |
| 500:5 | 0.3 | 0.3 | 1.2 | ---- | C 75 |
| 600:5 ³ | 0.3 | 0.3 | 0.6 | ---- | C 100 |
| 800:5 | 0.3 | 0.3 | 0.6 | 0.6 | C 130 |
| 1,000:5 | 0.3 | 0.3 | 0.3 | 0.3 | C 170 |
| 1,200:5 ³ | 0.3 | 0.3 | 0.3 | 0.3 | C 200 |
| 1,500:5 | 0.3 | 0.3 | 0.3 | 0.3 | C 200 |
| 2,000:5 ³ | 0.3 | 0.3 | 0.3 | 0.3 | C 200 |
| 2,500:5 | 0.3 | 0.3 | 0.3 | 0.3 | C 230 |
| 3,000:5 ³ | 0.3 | 0.3 | 0.3 | 0.3 | C 240 |
| 4,000:5 ³ | 0.3 | 0.3 | 0.3 | 0.3 | C 240 |
| Type MDD toroidal special accuracy ⁴ | | | | | |
| 75:5 | 2.4 ² | 4.8 | ---- | ---- | C 20 |
| 100:5 | 1.2 | 2.4 | ---- | ---- | C 30 |
| 150:5 | 0.6 | 1.2 | 2.4 | 4.8 | C 40 |
| 200:5 | 0.6 | 1.2 | 1.2 | 2.4 | C 60 |
| 250:5 | 0.3 | 0.6 | 1.2 | 2.4 | C 80 |
| 300:5 | 0.3 | 0.6 | 0.6 | 1.2 | C 100 |
| 400:5 | 0.3 | 0.3 | 0.6 | 0.6 | C 130 |
| 500:5 | 0.3 | 0.3 | 0.3 | 0.6 | C 160 |
| 600:5 ³ | 0.3 | 0.3 | 0.3 | 0.3 | C 210 |
| 800:5 | 0.3 | 0.3 | 0.3 | 0.3 | C 270 |
| 1,000:5 | 0.3 | 0.3 | 0.3 | 0.3 | C 340 |
| 1,200:5 ³ | 0.3 | 0.3 | 0.3 | 0.3 | C 425 |
| 1,500:5 | 0.3 | 0.3 | 0.3 | 0.3 | C 510 |
| 2,000:5 ³ | 0.3 | 0.3 | 0.3 | 0.3 | C 460 |
| 2,500:5 | 0.3 | 0.3 | 0.3 | 0.3 | C 580 |
| 3,000:5 ³ | 0.3 | 0.3 | 0.3 | 0.3 | C 660 |
| 4,000:5 ³ | 0.3 | 0.3 | 0.3 | 0.3 | C 460 |

Footnotes:

- ¹ One-second through current and momentary current are equal to the ratings of the associated circuit breakers.
- ² Exceeds ANSI/IEEE C37.20.2 accuracy limit.
- ³ Multi-ratio current transformers available. The accuracy ratings shown apply only to the full secondary winding.
- ⁴ Mounting restrictions:
 - MD: Up to two MD CTs per phase pn each primary disconnect bushing
 - MDD: Up to one MDD CT per phase on each primary disconnect bushing.

Table 10: Voltage transformers

| Voltage class | Ratio | Accuracy class | | | VA thermal rating |
|---------------|------------|----------------|-----|------|-------------------|
| | | X, Y | Z | ZZ | |
| 5 kV | 2,400/120 | 0.3 | 1.2 | ---- | 500 |
| 5 kV | 4,200/120 | 0.3 | 1.2 | ---- | 500 |
| 5 kV | 4,800/120 | 0.3 | 1.2 | ---- | 500 |
| 15 kV | 7,200/120 | 0.3 | 0.3 | 1.2 | 1,000 |
| 15 kV | 8,400/120 | 0.3 | 0.3 | 1.2 | 1,000 |
| 15 kV | 12,000/120 | 0.3 | 0.3 | 1.2 | 1,000 |
| 15 kV | 14,400/120 | 0.3 | 0.3 | 1.2 | 1,000 |

Table 11: Switchgear ratings

| Constant MVA ratings system | | | | | | | | |
|-----------------------------|--|------------------------|-------------------------------|--|---------------------|---------|---------------------------------------|---|
| Designation ¹ | Withstand voltage levels | | | Self-cooled main bus continuous current A rms ³ | Momentary withstand | | | |
| | Maximum design voltage kV rms ² | Power frequency kV rms | Lightning impulse BIL kV peak | | kA rms asymmetrical | kA peak | Short-time withstand current (2 s) kA | Internal arc resistance (IEEE C37.20.7) |
| GM-SG | 4.76 | 19 | 60 | 1,200, 2,000, 3,000, 4,000 | 58 | 97 | 36 | None |
| SGM-SG, S+GM-SG, OGM-SG | | | | 1,200, 2,000, 3,000, 4,000 ⁴ | 78 | 132 | 49 | |
| GM-SG | 8.25 | 36 | 95 | 1,200, 2,000, 3,000, 4,000 | 66 | 111 | 41 | |
| SGM-SG, S+GM-SG, OGM-SG | | | | 1,200, 2,000, 3,000, 4,000 ⁴ | | | | |
| GM-SG | 15.0 | 36 | 95 | 1,200, 2,000, 3,000, 4,000 | 37 | 62 | 23 | |
| SGM-SG, S+GM-SG, OGM-SG | | | | | 58 | 97 | 36 | |
| | | | | | 77 | 130 | 48 | |
| | | | | 1,200, 2,000, 3,000, 4,000 ⁴ | 37 | 62 | 23 | |
| 58 | | | | | 97 | 36 | | |
| 77 | | | | | 130 | 48 | | |

Footnotes:

- Designation refers to construction type for the equipment (indoor, outdoor non-walk-in, outdoor walk-in) as appropriate. Refer to Table 1: Type GM-SG family designation on page 5.
- Maximum design voltage for which the equipment is designed and the upper limit for operation.
- For self-cooled circuit breaker continuous current ratings, refer to Table 7: Type GMSG circuit breaker ratings (historic "constant MVA" ratings basis) on page 37.
- 3,000 A maximum in type OGM.

Table 11: Switchgear ratings (continued)

| Constant kA ratings system | | | | | | | | | | | |
|----------------------------|--|------------------------|-------------------------------|--|---------------------|---------|---------------------------------------|---|---|-----|----|
| Designation ¹ | Withstand voltage levels | | | Self-cooled main bus continuous current A rms ⁴ | Momentary withstand | | | | | | |
| | Maximum design voltage kV rms ² | Power frequency kV rms | Lightning impulse BIL kV peak | | kA rms asymmetrical | kA peak | Short-time withstand current (2 s) kA | Internal arc resistance (IEEE C37.20.7) | | | |
| GM-SG | 4.76 | 19 | 60 | 1,200, 2,000, 3,000, 4,000 | 62 | 104 | 40 | None | | | |
| | | | | | 78 | 130 | 50 | | | | |
| | | | | | 98 | 164 | 63 | | | | |
| SGM-SG, S+GM-SG, OGM-SG | | | | 1,200, 2,000, 3,000, 4,000 ⁵ | 62 | 104 | 40 | | | | |
| | | | | | 78 | 130 | 50 | | | | |
| | | | | | 98 | 164 | 63 | | | | |
| GM-SG | 8.25 | 36 | 95 | 1,200, 2,000, 3,000, 4,000 | 62 | 104 | 40 | | | | |
| SGM-SG, S+GM-SG, OGM-SG | | | | | | | | | 1,200, 2,000, 3,000, 4,000 ⁵ | | |
| | | | | | | | | | | | |
| GM-SG | | | | 15.0 | 36 | 95 | 1,200, 2,000, 3,000, 4,000 | | | 39 | 65 |
| | | | | | | | | | 62 | 104 | 40 |
| | | | | | | | | | 78 | 130 | 50 |
| SGM-SG, S+GM-SG, OGM-SG | 1,200, 2,000, 3,000, 4,000 ⁵ | 98 | 164 | | | | 63 | | | | |
| | | 39 | 65 | | | | 25 | | | | |
| | | 62 | 104 | | | | 40 | | | | |
| | | | | 78 | 130 | 50 | | | | | |
| | | | | 98 | 164 | 63 | | | | | |
| GM-SG-AR | 4.76 | 19 | 60 | 1,200, 2,000, 3,000, 4,000 | 62 | 104 | 40 | Accessibility type 2B, 0.5 s ³ | | | |
| | | | | | 78 | 130 | 50 | | | | |
| | | | | | 98 | 164 | 63 | | | | |
| SGM-SG-AR, S+GM-SG-AR | | | | 1,200, 2,000, 3,000, 4,000 ⁵ | 62 | 104 | 40 | | | | |
| | | | | | 78 | 130 | 50 | | | | |
| | | | | | 98 | 164 | 63 | | | | |
| GM-SG-AR | 8.25 | 36 | 95 | 1,200, 2,000, 3,000, 4,000 | 62 | 104 | 40 | | | | |
| SGM-SG-AR | | | | | | | | | 1,200, 2,000, 3,000, 4,000 ⁵ | | |
| | | | | | | | | | | | |
| GM-SG-AR | | | | 15.0 | 36 | 95 | 1,200, 2,000, 3,000, 4,000 | | | 39 | 65 |
| | | | | | | | | | 62 | 104 | 40 |
| | | | | | | | | | 78 | 130 | 50 |
| SGM-SG-AR, S+GM-SG-AR | 1,200, 2,000, 3,000, 4,000 ⁵ | 98 | 164 | | | | 63 | | | | |
| | | 39 | 65 | | | | 25 | | | | |
| | | 62 | 104 | | | | 40 | | | | |
| | | | | 78 | 130 | 50 | | | | | |
| | | | | 98 | 164 | 63 | | | | | |

Footnotes:

- ¹ Designation refers to construction type for the equipment (indoor, outdoor non-walk-in, outdoor walk-in, arc-resistant) as appropriate. Refer to Table 1: Type GM-SG family designation on page 5.
- ² Maximum design voltage for which the equipment is designed and the upper limit for operation.

- ³ Minimum of two section lineup.
- ⁴ For self-cooled circuit breaker continuous current ratings, refer to Table 6: Type GMSG circuit breaker ratings (new "constant kA" ratings basis) on page 36.
- ⁵ 3,000 A maximum in type OGM.

Table 12: Dimensions¹

| Type | Dimensions in inches (mm) ¹³ | | | | Weight lbs (kg) ¹² |
|----------------------|---|-----------------------------|---------------------------------|---------------------------------------|-------------------------------|
| | Height | Width | Depth ³ | Drawout aisle | |
| GM-SG | 95.3 (2,419) | 36.0 (914) | 98.7 (2,507) ⁴ | 72.0 (1,829) recommended ⁶ | 3,300 (1,497) |
| SGM-SG ¹⁴ | 114.8 (2,915) | 36.0 (914) ² | 173.4 (4,404) ⁵ | 72.0 (1,829) included | 5,000 (2,268) |
| OGM-SG | 113.6 (2,886) | 36.0 (914) ² | 101.9 (2,588) ^{5,10} | 72.0 (1,829) recommended ⁶ | 3,950 (1,792) |
| GM-SG-AR | 116.4 (2,957) ⁹ | 40.0 (1,016) ^{7,8} | 102.8 (2,611) ^{4,9,11} | 72.0 (1,829) recommended ⁶ | 4,100 (1,864) |
| SGM-SG-AR | 135.6 (3,444) | 40.0 (1,016) ^{7,8} | 179.8 (4,566) ⁵ | 72.0 (1,829) included | 5,900 (2,682) |

Footnotes:

- ¹ Dimensions are approximate.
- ² Add 6" (152 mm) to each end of the lineup for aisle extension 12" (304 mm) total.
- ³ Dimensions are approximate size of floor footprint. For outdoor equipment, enclosure overhangs floor frame. Refer to Footnote 5.
- ⁴ If indoor switchgear is installed on a raised housekeeping pad, the pad must not extend farther than 3" (75 mm) from the front of the switchgear to avoid interference with the use of the portable lift truck.
- ⁵ Add for roof and enclosure overhang:
 - Rear (cable side):
 - Non-walk-in: 3.6" (92 mm)
 - Shelter-Clad: 3.6" (92 mm).
 - Front (drawout side):
 - Non-walk-in: 3.7" (94 mm)
 - Shelter-Clad: 1.7" (43 mm).
- ⁶ 72" (1,829 mm) aisle space recommended allows room for interchange of circuit breakers. Minimum aisle space required for handling circuit breaker with lift truck is 65" (1,651 mm). Minimum aisle space required if all circuit breakers are at floor level is 55" (1,397 mm).
- ⁷ Add 9" (229 mm) to length of the lineup for end trims.
- ⁸ The switchgear must have at least 6" (152 mm) horizontal clearance:
 - From left and right sides to nearest wall or equipment, and
 - From rearmost extension of vents on rear to nearest wall or equipment.
- ⁹ No obstructions permitted within 10" (254 mm) of top of switchgear structure.
- ¹⁰ Add 4.5" (114 mm) to depth for front and rear doors.
- ¹¹ Add 1.0" (25 mm) for GM-SG-AR equipment rated 63 kA.
- ¹² Add weight of circuit breakers from Table 13.
- ¹³ Maximum shipping group five sections for GM-SG non-arc-resistant switchgear; four sections for all other types.
- ¹⁴ Shelter-Clad+ switchgear assemblies (types S+GM-SG and S+GM-SG-AR) are built in partnership with Siemens-qualified vendors, who provide detailed drawings of each custom assembly which include dimensions and weights. Please be sure to carefully review and follow all instructions provided in the order-specific Shelter-Clad+ drawing package.

 Table 13: Type GMSG vacuum circuit breaker weight in lbs (kg)^{1,2,3}

| Circuit breaker type | Continuous current A | | |
|------------------------------|----------------------|-----------|-----------|
| | 1,200 | 2,000 | 3,000 |
| 5-GMSG-40/5-GMSG-250 | 440 (200) | 650 (295) | 665 (302) |
| 5-GMSG-50/5-GMSG-350 | 455 (206) | 665 (302) | 670 (304) |
| 5-GMSG-63 | 809 (368) | 819 (372) | 824 (375) |
| 7-GMSG-40/7-GMSG-500 | 455 (206) | 665 (302) | 675 (306) |
| 15-GMSG-25/15-GMSG-500 | 430 (195) | 640 (290) | ---- |
| 15-GMSG-40/15-GMSG-750 | 445 (202) | 670 (304) | 675 (306) |
| 15-GMSG-50/15-GMSG-1000 | 460 (209) | 675 (306) | 680 (308) |
| 15-GMSG-63 | 819 (372) | 829 (377) | 834 (379) |
| 5-GMSG-GCB-40/15-GMSG-GCB-40 | 475 (215) | 685 (311) | 715 (324) |
| 5-GMSG-GCB-50/15-GMSG-GCB-50 | 825 (374) | 835 (379) | 865 (392) |
| 5-GMSG-GCB-63/15-GMSG-GCB-63 | 875 (397) | 900 (408) | 930 (427) |

Footnotes:

- ¹ Weight is approximate.
- ² Approximate circuit breaker (width x depth x height): 32" (813 mm) x 39" (991 mm) x 36" (914 mm). If packed for shipment separate from switchgear : 42" (1,067 mm) x 47" (1,194 mm) x 43" (1,092 mm).
- ³ Weight estimates are for circuit breaker only. Add 75 lbs (34 kg) if shipped separately packaged.

Stacking versatility

Figure 44: Stacking versatility



Footnotes for GM-SG non-arc-resistant (up to 63 kA) and GM-SG-AR arc-resistant (up to 50 kA) :

1. Main bus sizes 1,200 A, 2,000 A, 3,000 A or 4,000 A (self-cooled).
2. No rollout auxiliaries allowed in upper cell (C or D) if lower cell (B) has 3,000 A circuit breaker.
3. If 3,000 A circuit breaker is located in upper cell (A), one rollout auxiliary may be located in lower cell (F).
4. Fuse rollout for stationary CPT must be located in lower rollout cell F, if CPT is located in rear or is remote.
5. Stacking arrangements are available as shown for all types of equipment in the GM-SG family. Total circuit breaker loading in a vertical unit may not exceed main bus rating.
6. Consult Siemens for specific application assistance regarding total load limits in each unit or refer to ANSI/IEEE C37.20.2.
7. Generator circuit breakers (type GMSG-GCB) conform to same stacking rules as standard (non-generator) circuit breakers.
8. For fan-cooled 4,000 A rating, circuit breaker (3,000 A self-cooled, 4,000 A fan-cooled) may be located in lower cell (B) with fan cooling in cell (A) (indoor only).

Figure 44: Stacking versatility (continued)



Footnotes for GM-SG-AR arc-resistant 63 kA:

- ¹ Main bus sizes 1,200 A, 2,000 A, 3,000 A or 4,000 A (self-cooled).
- ² No rollout auxiliaries allowed in upper cell (A) if lower cell (B) has 3,000 A circuit breaker.
- ³ Auxiliary cells (A or B) may each contain one rollout (except as indicated in Footnotes 2 and 7).
- ⁴ Fuse rollout for stationary CPT must be located in lower rollout cell (B), if CPT is located in rear or is remote.
- ⁵ Stacking arrangements are available as shown for arc-resistant type GM-SG-AR equipment rated 63 kA. Total circuit breaker loading in a vertical unit may not exceed main bus rating. Consult Siemens for specific application assistance regarding total load limits in each unit or refer to ANSI/IEEE C37.20.2.
- ⁶ Generator circuit breakers (type GMSG-GCB) conform to same stacking rules as standard (non-generator) circuit breakers.
- ⁷ For fan-cooled 4,000 A rating, circuit breaker (3,000 A self-cooled, 4,000 A fan-cooled) may be located in lower cell (B) with fan cooling in cell (A) (indoor only).

Side views

Figure 45: Side views

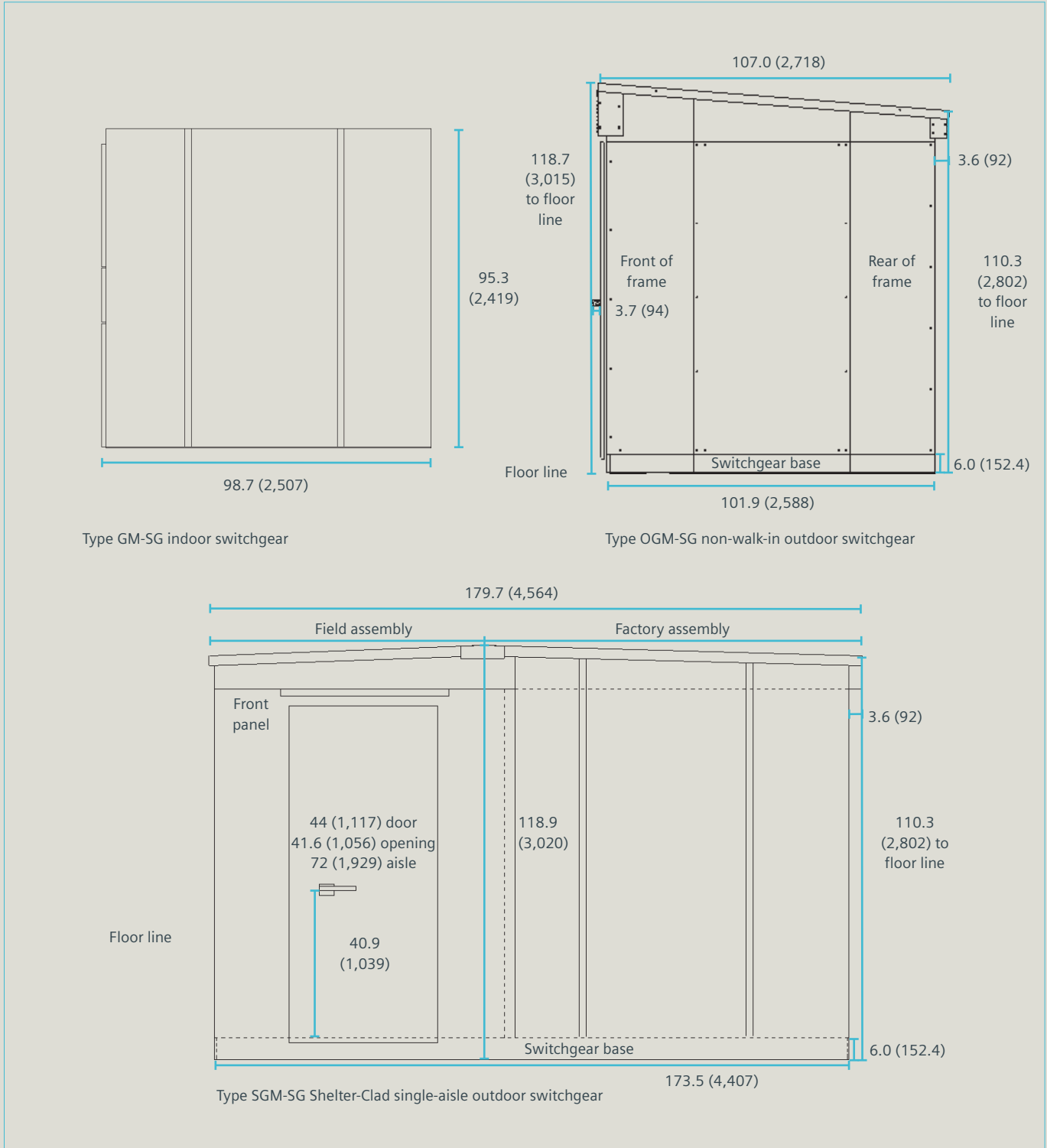
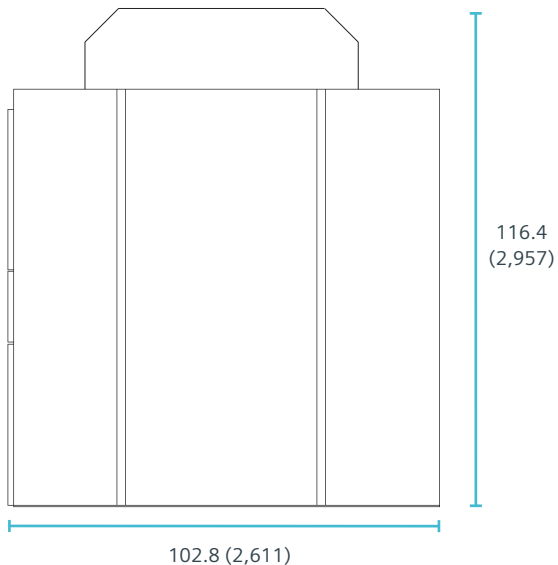
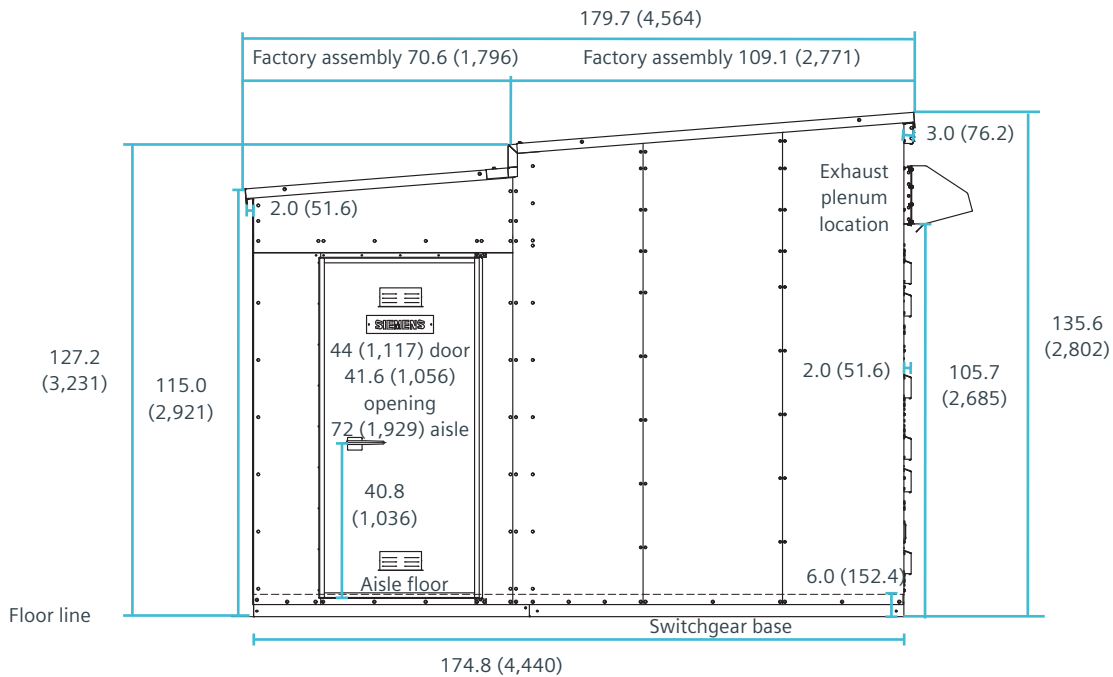

Figure 45: Side views (continued)



Type GM-SG-AR indoor switchgear



Type SGM-SG-AR Shelter-Clad single-aisle outdoor switchgear

Shelter-Clad+ switchgear assemblies are built in partnership with Siemens-qualified vendors, who provide detailed drawings of each custom assembly which include lifting, handling, support, and installation instructions. Please be sure to carefully review and follow all instructions provided in the order-specific Shelter-Clad+ drawing package.

Anchoring and section arrangements

Figure 45: Anchoring indoor type GM-SG switchgear

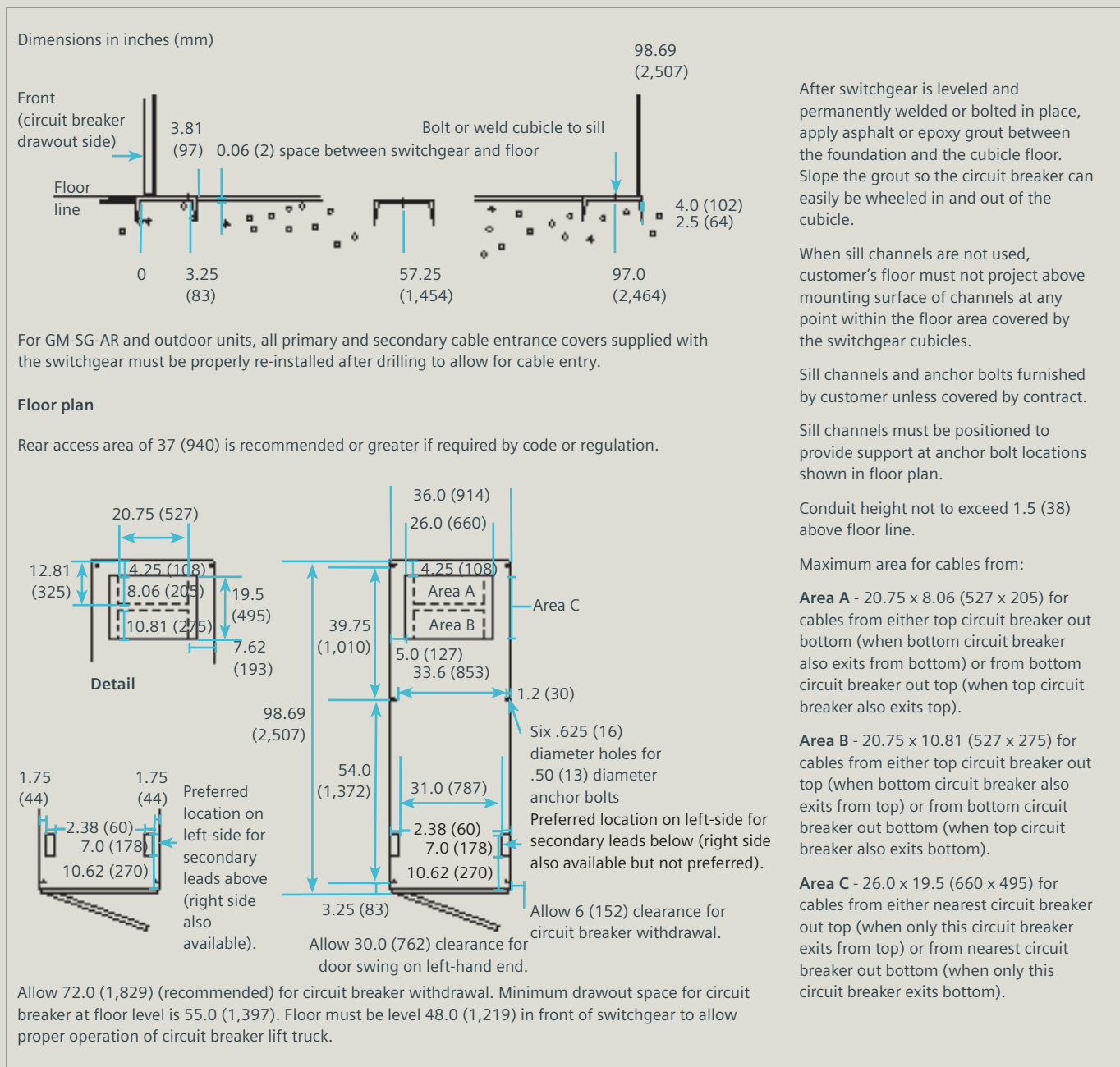

Figure 46: Anchoring indoor type GM-SG-AR switchgear

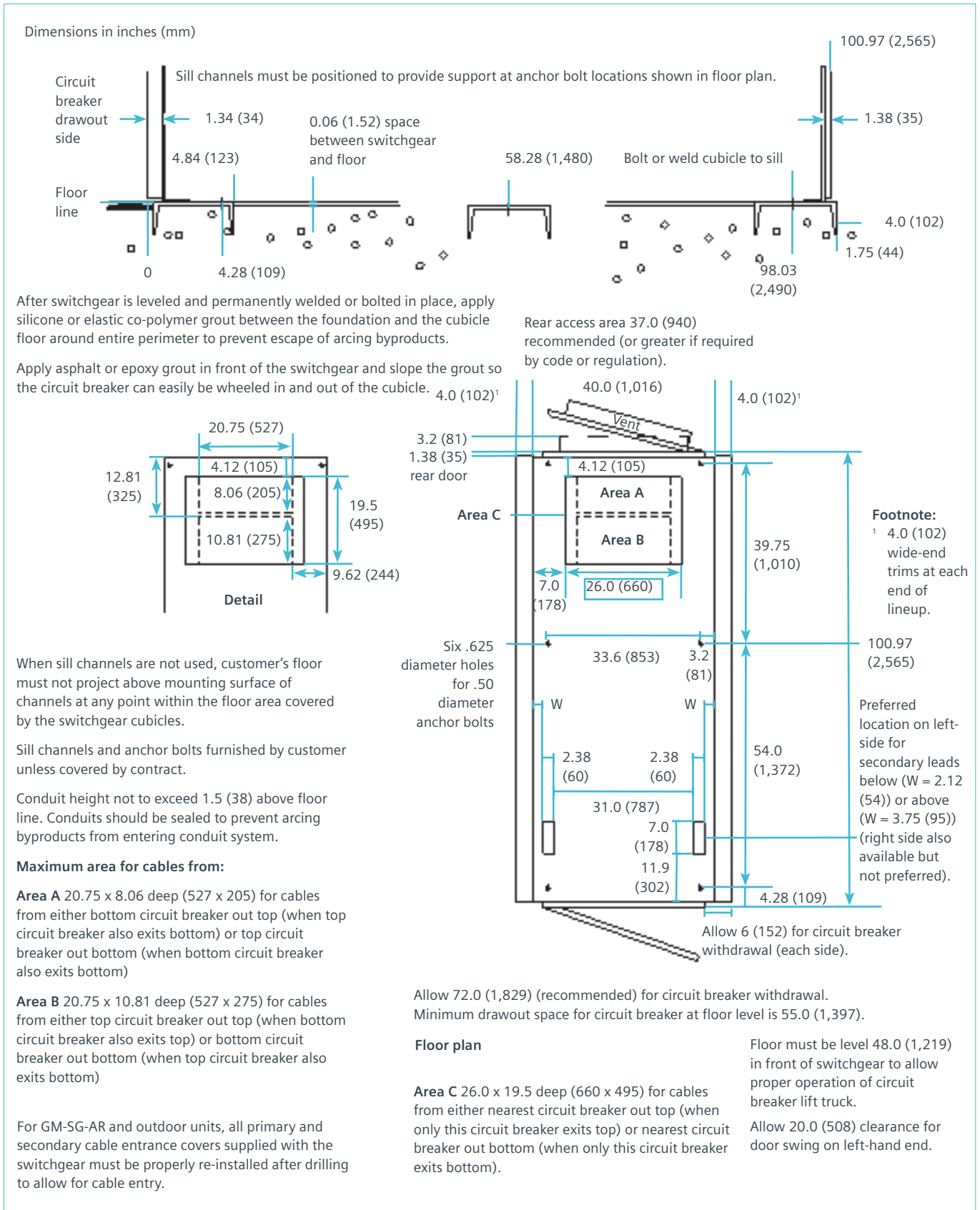

Figure 47: Section arrangement for GM-SG non-arc-resistant (up to 63 kA) and GM-SG-AR arc-resistant (up to 50 kA)¹⁻⁷

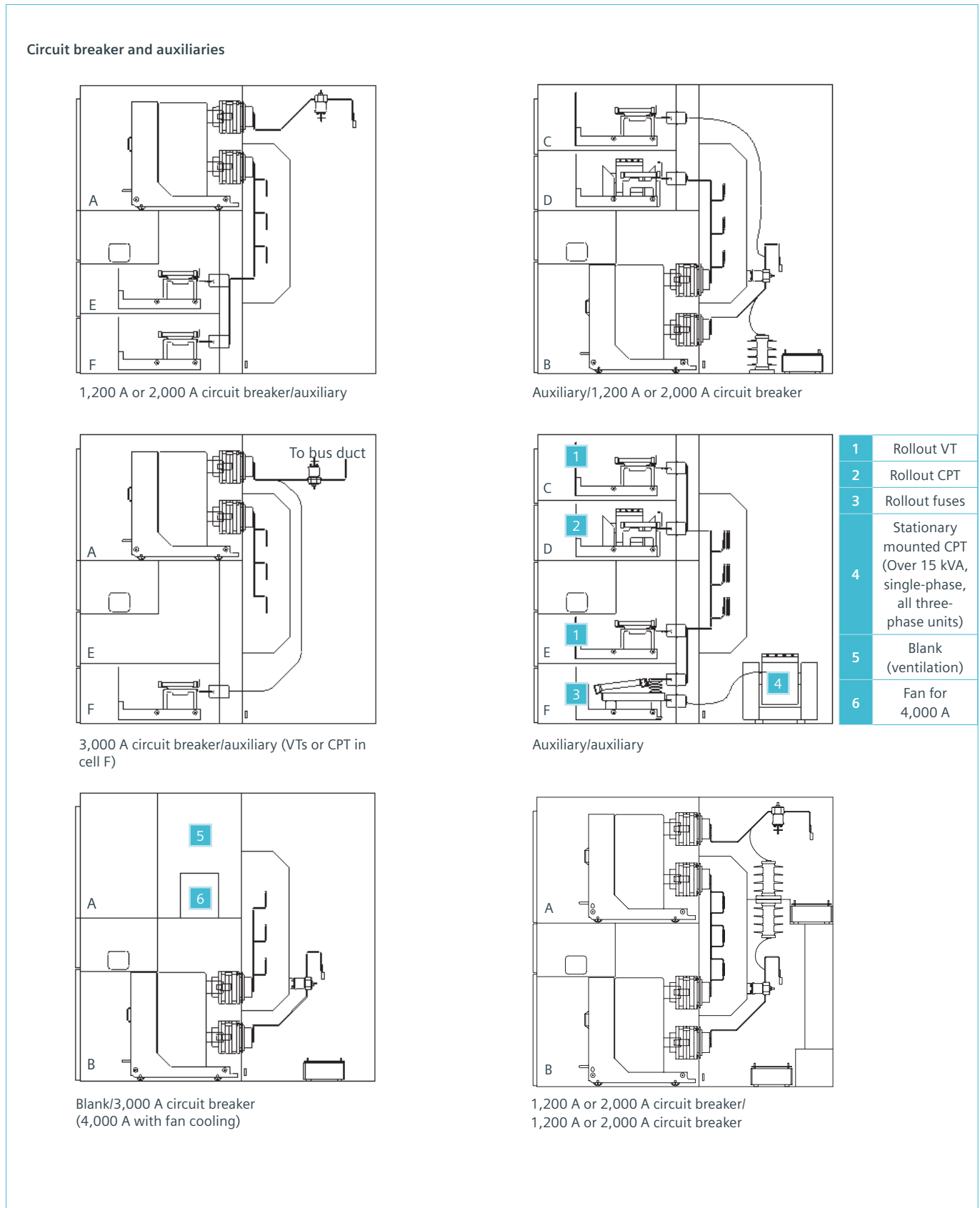
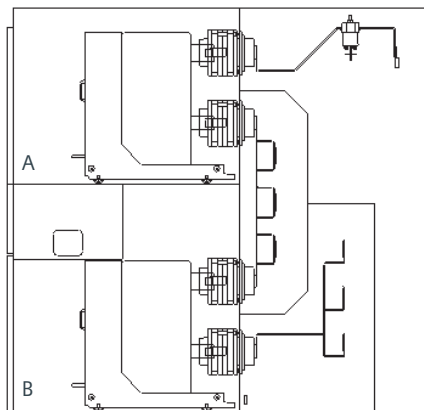
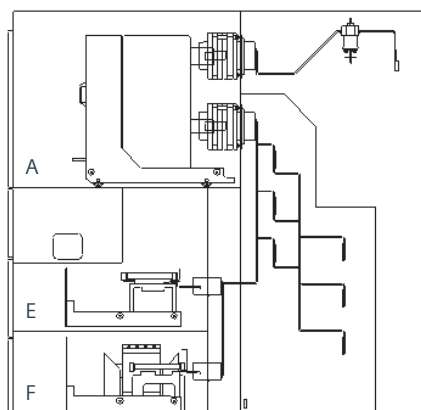

Figure 47: Section arrangement for GM-SG non-arc-resistant (up to 63 kA) and GM-SG-AR arc-resistant (up to 50 kA)¹⁻⁷ (continued)

Bus tie arrangements



Unit with bus tie circuit breaker in lower compartment



Unit adjacent to lower bus tie - cell F suitable for VTs or CPT only

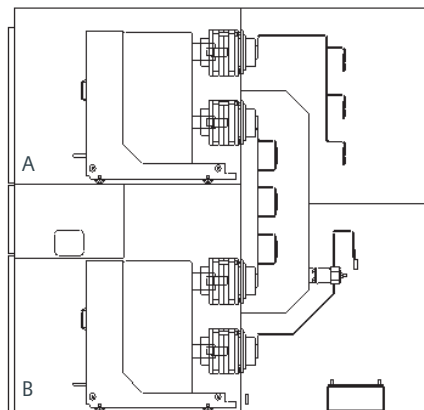

Unit with bus tie compartment in upper compartment

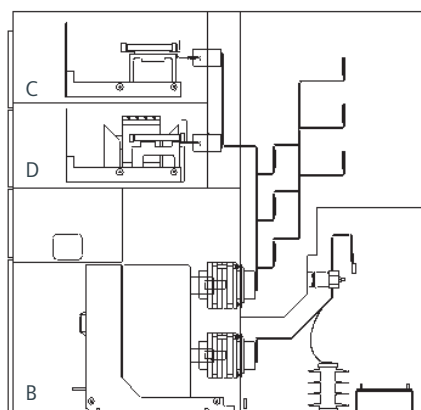

Unit adjacent to upper bus tie

Footnotes:

1. Bus tie circuit breaker (1,200 A, 2,000 A, 3,000 A) may be located in upper or lower compartment, as desired. Bus tie circuit breaker (4,000 A) must be located in lower cell.
2. Adjacent unit must normally have auxiliary compartment at same level as bus tie circuit breaker to accommodate transition bus. Consult Siemens if auxiliary compartment at same level as bus tie circuit breaker is not available.
3. Units with 1,200 A or 2,000 A bus tie circuit breakers may have a 1,200 A or 2,000 A feeder circuit breaker located in the same unit.
4. Units with 3,000 A or 4,000 A bus tie circuit breaker in the lower cell must have a vented auxiliary compartment (no rollout auxiliaries) above the circuit breaker. Units with 3,000 A bus tie circuit breaker in upper cell may have one rollout auxiliary in cell F.
5. Maximum main bus size 4,000 A (self-cooled).
6. A = upper compartment for circuit breaker or non-rollout auxiliaries. B = lower compartment for circuit breaker or non-rollout auxiliaries. C = VTs. D = VTs or CPT. E = VTs. F = VTs, CPT or rollout fuses for stationary CPT.
7. All available for both arc-resistant (up to 50 kA) and non-arc-resistant (up to 63 kA) structures.

Figure 48: Section arrangement for GM-SG-AR arc-resistant (up to 63 kA)¹⁻⁶

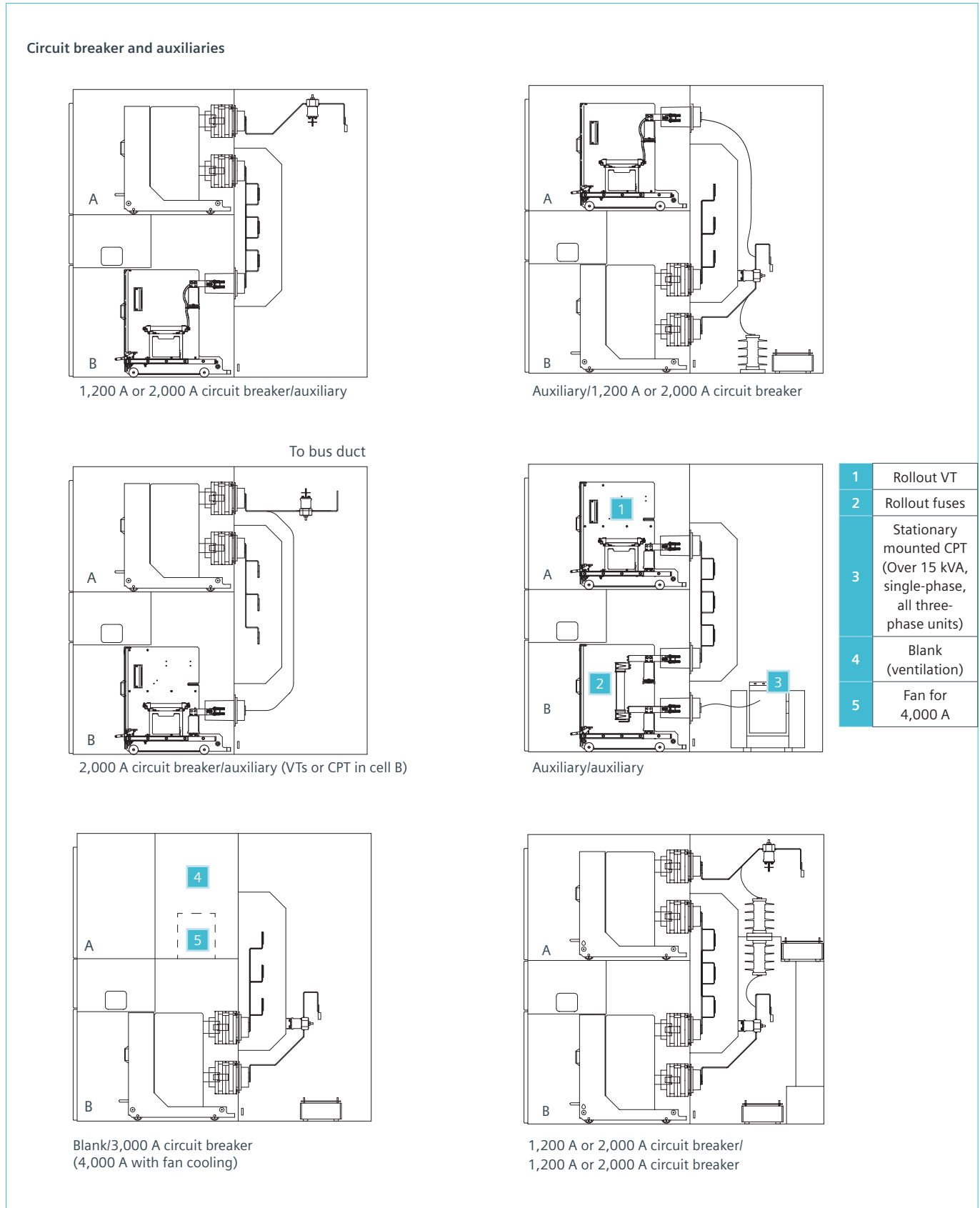
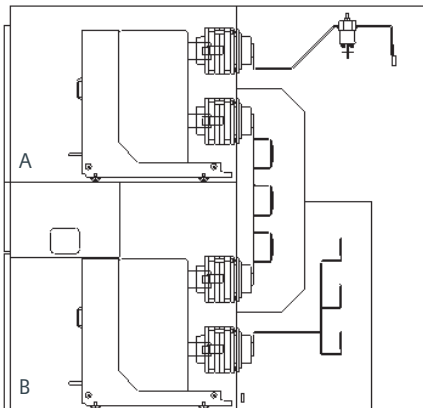
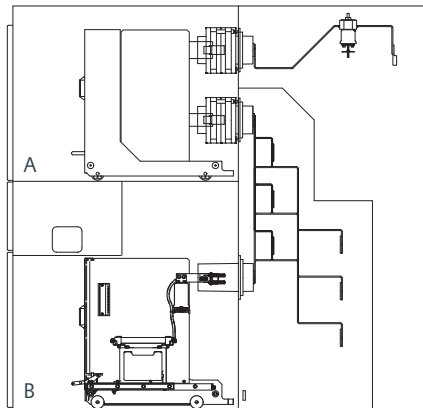

Figure 47: Section arrangement for GM-SG-AR arc-resistant (up to 63 kA)¹⁻⁶ (continued)

Bus tie arrangements



Unit with bus tie circuit breaker in lower compartment



Unit adjacent to lower bus tie - cell F suitable for VTs or CPT only

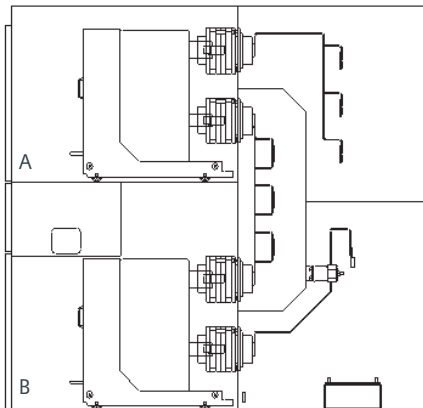

Unit with bus tie compartment in upper compartment

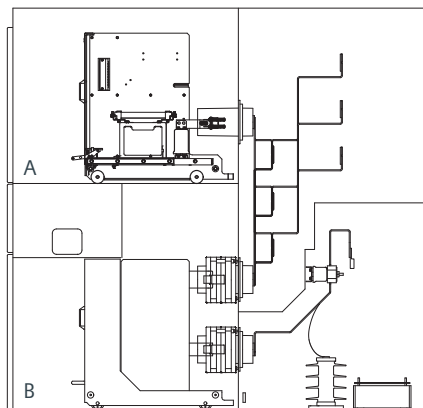

Unit adjacent to upper bus tie

Footnotes:

1. Bus tie circuit breaker (1,200 A or 2,000 A) may be located in upper or lower compartment, as desired. Bus tie circuit breaker (3,000 A or 4,000 A) must be located in lower cell.
2. Adjacent unit must normally have auxiliary compartment at same level as bus tie circuit breaker to accommodate transition bus. Consult Siemens if auxiliary compartment at same level as bus tie circuit breaker is not available.
3. Units with 1,200 A or 2,000 A bus tie circuit breakers may have a 1,200 A or 2,000 A feeder circuit breaker located in the same unit.
4. Units with 3,000 A or 4,000 A bus tie circuit breaker in the lower cell must have a vented auxiliary compartment (no rollout auxiliaries) above the circuit breaker.
5. Maximum main bus size 4,000 A (self-cooled).
6. A = upper compartment for circuit breaker or rollout auxiliaries. B = lower compartment for circuit breaker or rollout auxiliaries. A or B VTs, CPT or rollout fuses for stationary CPT.

Published by Siemens Industry, Inc. 2017.

Siemens Industry, Inc.
7000 Siemens Road
Wendell, North Carolina 27591

For more information, please contact our Customer Support Center.
Phone: +1 (800) 333-7421

www.usa.siemens.com/mvswitchgear

Order No. EMMS-T40007-01-4A00

Printed in U.S.A.

© 2017 Siemens Industry, Inc.

The technical data presented in this document is based on an actual case or on as-designed parameters, and therefore should not be relied upon for any specific application and does not constitute a performance guarantee for any projects. Actual results are dependent on variable conditions. Accordingly, Siemens does not make representations, warranties, or assurances as to the accuracy, currency or completeness of the content contained herein. If requested, we will provide specific technical data or specifications with respect to any customer's particular applications. Our company is constantly involved in engineering and development. For that reason, we reserve the right to modify, at any time, the technology and product specifications contained herein.