

Electronic Trip Unit, LI Model

Switch 1	I_n - Maximum trip unit rating (amps)	I_r - Continuous current rating (amps)									
	200	80	90	100	110	120	130	140	160	180	200
300	120	135	150	165	180	190	210	240	270	300	
400	150	160	175	200	225	250	300	315	350	400	

Switch 2	I_n - Maximum trip unit rating (amps)	t_{ld} - Long time delay (seconds @ $6 \times I_r$)									
	200, 300, 400	2.5	4	6	8	10	14	17	20	25	30

Switch 3	I_n - Maximum trip unit rating (amps)	I_i - Instantaneous pickup (amps)									
	200	250	300	400	600	800	1000	1200	1600	2000	2100
300	375	450	600	900	1200	1500	1800	2400	3000	3150	
400	500	600	800	1200	1600	2000	2400	3200	4000	4200	

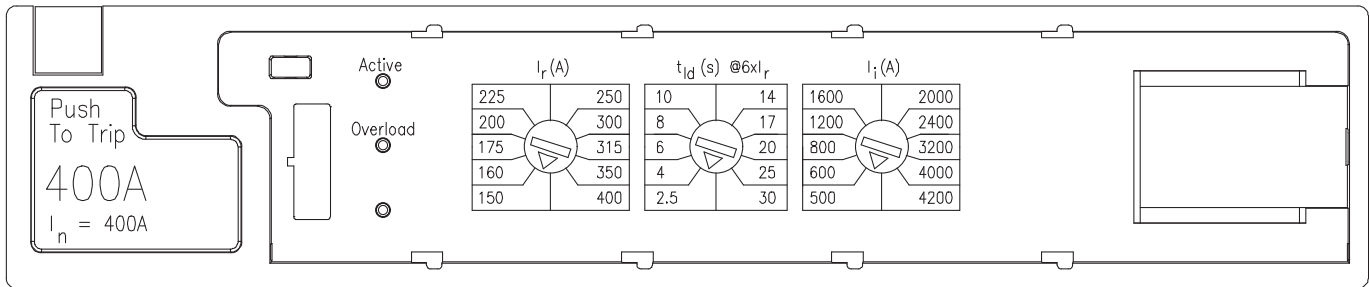

References

I_n = Maximum circuit breaker ampere rating

I_r = Continuous current rating expressed in amperes

I_i = Instantaneous pickup expressed in amperes

I_{sd} = Short time pickup expressed in multiples of I_r

I_g = Ground fault pickup expressed in amperes

t_{sd} = Short time delay - either fixed or I^2t time delay function

t_{ld} = Long time delay - I^2t time delay function

t_g = Ground fault delay - I^2t time delay function

Electronic Trip Unit, LIG Model

Switch 1	I_n - Maximum trip unit rating (amps)	I_r - Continuous current rating (amps)									
	200	80	90	100	110	120	130	140	160	180	200
	300	120	135	150	165	180	190	210	240	270	300
400	150	160	175	200	225	250	300	315	350	400	

Switch 2	I_n - Maximum trip unit rating (amps)	t_{ld} - Long time delay (seconds @ $6 \times I_r$)									
	200, 300, 400	2.5	4	6	8	10	14	17	20	25	30

Switch 3	I_n - Maximum trip unit rating (amps)	I_i - Instantaneous pickup (amps)									
	200	250	300	400	600	800	1000	1200	1600	2000	2100
	300	375	450	600	900	1200	1500	1800	2400	3000	3150
400	500	600	800	1200	1600	2000	2400	3200	4000	4200	

Switch 4	I_n - Maximum trip unit rating (amps)	I_g - Ground fault pickup (amps)									
	200	160	80	80	80	120	120	120	200	200	200
	300	240	120	120	120	180	180	180	300	300	300
400	320	160	160	160	240	240	240	400	400	400	

Switch 4	I_n - Maximum trip unit rating (amps)	t_g - Ground fault delay (seconds)									
	200, 300	0.1	0.1	0.2	0.3	0.1	0.2	0.3	0.1	0.2	0.3
	400	0.11	0.1	0.2	0.3	0.1	0.2	0.3	0.1	0.2	0.3

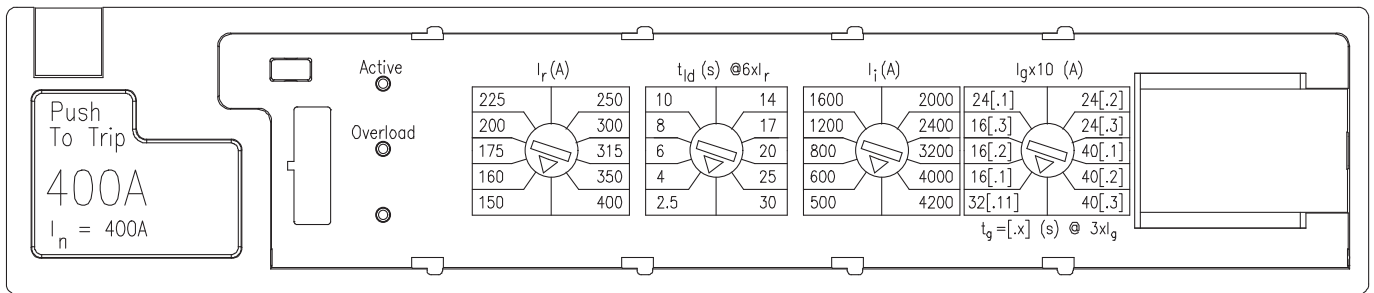

References

I_n = Maximum circuit breaker ampere rating

I_r = Continuous current rating expressed in amperes

I_i = Instantaneous pickup expressed in amperes

I_{sd} = Short time pickup expressed in multiples of I_r

I_g = Ground fault pickup expressed in amperes

t_{sd} = Short time delay - either fixed or I^2t time delay function

t_{ld} = Long time delay - I^2t time delay function

t_g = Ground fault delay - I^2t time delay function

Electronic Trip Unit, LSI Model

Switch 1	I_n - Maximum trip unit rating (amps)	I_r - Continuous amp (amps)									
	200	100	120	140	160	200	100	120	140	160	200
	300	150	180	210	240	300	150	180	210	240	300
	400	200	250	300	350	400	200	250	300	350	400
Switch 1	I_n - Maximum trip unit rating (amps)	t_{ld} - Long time delay (seconds @ 6 x I_r)									
	200, 300, 400	10	10	10	10	10	20	20	20	20	20

Switch 2	I_n - Maximum trip unit rating (amps)	I_{sd} - Short time pickup (amps) x I_r									
	200, 300, 400	1.5	2	2.5	3	4	5	6	7	8	10

Switch 3	I_n - Maximum trip unit rating (amps)	t_{sd} - Short time delay (seconds)									
	200, 300, 400	0.1-FIXED	0.2-FIXED	0.3-FIXED	0.4-FIXED	0.5-FIXED	0.1 - 8x I_r	0.2 - 8x I_r	0.3 - 8x I_r	0.4 - 8x I_r	0.5 - 8x I_r

Switch 4	I_n - Maximum trip unit rating (amps)	I_i - Instantaneous pickup (amps)									
	200	250	300	400	600	800	1000	1200	1600	2000	2100
	300	375	450	600	900	1200	1500	1800	2400	3000	3150
	400	500	600	800	1200	1600	2000	2400	3200	4000	4200

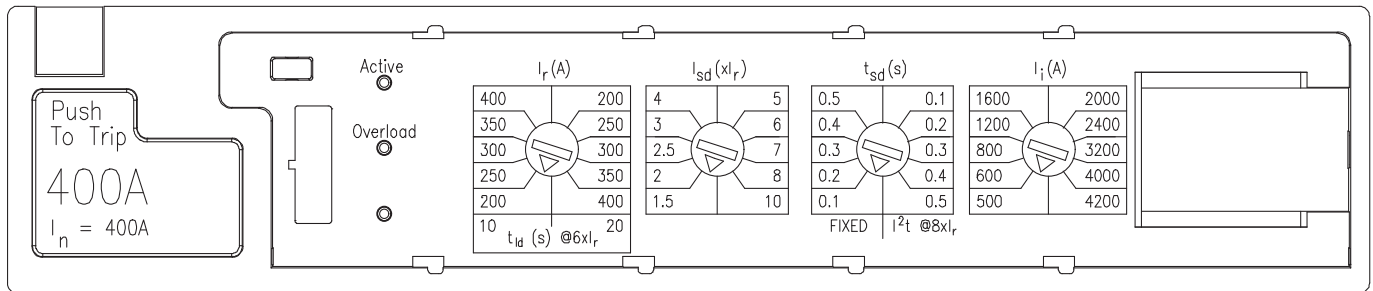

References

I_n = Maximum circuit breaker ampere rating

I_r = Continuous current rating expressed in amperes

I_i = Instantaneous pickup expressed in amperes

I_{sd} = Short time pickup expressed in multiples of I_r

I_g = Ground fault pickup expressed in amperes

t_{sd} = Short time delay - either fixed or I^2t time delay function

t_{ld} = Long time delay - I^2t time delay function

t_g = Ground fault delay - I^2t time delay function

Electronic Trip Unit, LSIG Model

Switch 1	I_n - Maximum trip unit rating (amps)	I_r - Continuous amp (amps)									
	200	100	120	140	160	200	100	120	140	160	200
	300	150	180	210	240	300	150	180	210	240	300
	400	200	250	300	350	400	200	250	300	350	400
Switch 1	I_n - Maximum trip unit rating (amps)	t_{ld} - Long time delay (seconds @ 6 x I_r)									
	200, 300, 400	10	10	10	10	10	20	20	20	20	20

Switch 2	I_n - Maximum trip unit rating (amps)	I_{sd} - Short time pickup (amps) x I_r										
	200, 300, 400	1.5	2	2.5	3	4	5	6	7	8	10	
	Switch 2	I_n - Maximum trip unit rating (amps)	I_i - Instantaneous pickup (amps)									
		200	1000	1000	1000	1000	1000	2100	2100	2100	2100	2100
300		1500	1500	1500	1500	1500	3150	3150	3150	3150	3150	
400	2000	2000	2000	2000	2000	4200	4200	4200	4200	4200		

Switch 3	I_n - Maximum trip unit rating (amps)	t_{sd} - Short time delay (seconds)									
	200, 300, 400	0.1-FIXED	0.2-FIXED	0.3-FIXED	0.4-FIXED	0.5-FIXED	0.1 - 8x I_r	0.2 - 8x I_r	0.3 - 8x I_r	0.4 - 8x I_r	0.5 - 8x I_r

Switch 4	I_n - Maximum trip unit rating (amps)	I_g - Ground fault pickup (amps)									
	200	160	80	80	80	120	120	120	200	200	200
	300	240	120	120	120	180	180	180	300	300	300
	400	320	160	160	160	240	240	240	400	400	400
Switch 4	I_n - Maximum trip unit rating (amps)	t_g - Ground fault delay									
	200, 300	0.1	0.1	0.2	0.3	0.1	0.2	0.3	0.1	0.2	0.3
	400	0.11	0.1	0.2	0.3	0.1	0.2	0.3	0.1	0.2	0.3

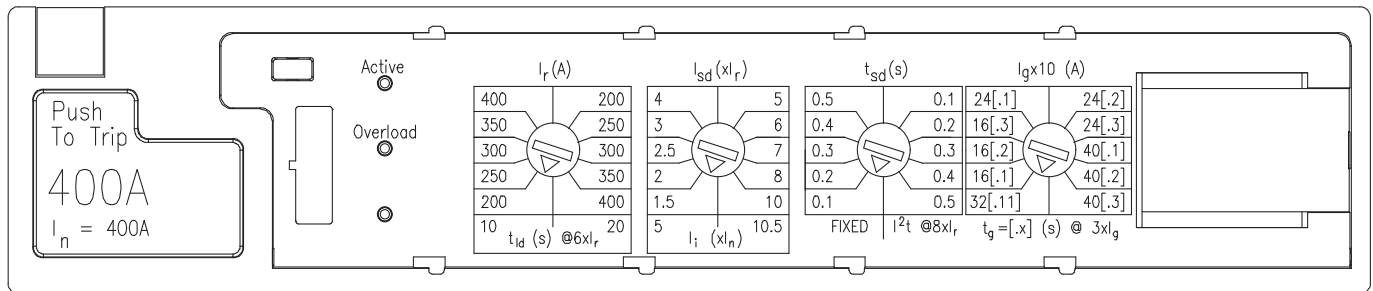

References

I_n = Maximum circuit breaker ampere rating

I_r = Continuous current rating expressed in amperes

I_i = Instantaneous pickup expressed in amperes

I_{sd} = Short time pickup expressed in multiples of I_r

I_g = Ground fault pickup expressed in amperes

t_{sd} = Short time delay - either fixed or I^2t time delay function

t_{ld} = Long time delay - I^2t time delay function

t_g = Ground fault delay - I^2t time delay function

Shipping Weights

Breaker Type	Number per Carton	Shipping Weight (lbs)
SJD6-B	1	20
SHJD6-B	1	20
SCJD6-B	1	33

Accessories

Shunt Trip Combinations

Control Voltage		1 Shunt Trip	1 Shunt Trip and 1 Auxiliary Switch
AC	DC	Catalog Number	Catalog Number
24		S17JLD6	-
48		S18JLD6	-
120		S01JLD6	S01JLD62A
240		S03JLD6	S03JLD62A
277		S15JLD6	S15JLD64A
480		S04JLD6	-
	12	S16JLD6	S16JLD62A
	24	S07JLD6	S07JLD62A
	48	S09JLD6	S09JLD62A
	125	S11JLD6	S11JLD62A
	250	S13JLD6	S13JLD62A

Lugs for 75°C Wire

Catalog Number	No of Cables per Connector	Wire Range
TA2J6500	2	#3/0-500 kcmil Cu
	2	#4/0-500 kcmil Al
TA1L6750	1	500-750 kcmil Al
	1	500-600 kcmil Cu
TC1J6600	1	#3/0-600 kcmil Cu
TC2J6500	2	#3/0-500 kcmil Cu
TA2J630	2	#4-#3/0-Cu/Al
Compression Lug		
CCL600	(1 pc.)	#1/0-500 kcmil Cu/Al

Undervoltage Trip Combinations

Control Voltage		1 Undervoltage Trip	1 Undervoltage Trip and 1 Auxiliary Switch	1 Undervoltage Trip and 2 Auxiliary Switches
AC	DC	Catalog Number	Catalog Number	Catalog Number
120		U01JLD6	U01JLD62A	U01JLD62AA
208		U02JLD6	U02JLD62A	U02JLD62AA
240		U03JLD6	U03JLD62A	U03JLD62AA
480		U06JLD6	U06JLD64A	U06JLD64AA
	24	U13JLD6	U13JLD62A	U13JLD62AA
	48	U14JLD6	U14JLD62A	U14JLD62AA
	125	U10JLD6	U10JLD62A	U10JLD62AA
	250	U12JLD6	U12JLD62A	U12JLD62AA

Neutral Transformers

Ampere Rating	Catalog Number
200	N02SJD
300	N03SJD
400	N04SJD

Note: Accessory modules can only be added to right side pole of solid state SJD and SLD frame circuit breakers. No accessories can be added if mechanical interlock is used.

Accessories

Auxiliary Switch Combinations

Maximum Voltage		1 Form C	2 Form C
AC	DC	Catalog Number	Catalog Number
480	250	A01JLD64	A02JLD64
-	12	A01JLDLV	A02JLDLV

Alarm Switch Combinations

Maximum Voltage		1 Alarm Switch	1 Alarm Switch and 1 Auxiliary Switch	1 Alarm Switch and 2 Auxiliary Switches
AC	DC	Catalog Number	Catalog Number	Catalog Number
480	250	B01JLD64	A01JLD64B	A02JLD64B

ETU Testing Unit

Breaker Type	Description	Catalog Number
SJD, SLD, SMD, SND, SPD	Power Stick	EPSP18V
	Spare cable for Power Stick	COMPCA

The EPSP18V Power Stick is a hand-held, battery-operated power supply that can be used for trip testing the Sensitrip IV electronic trip units. Requires two 9V batteries.

Note: Accessory modules can only be added to right side pole of solid state SJD and SLD frame circuit breakers. No accessories can be added if mechanical interlock is used.

DAS / Maintenance Mode Option and ZSI

- Optional advanced trip units incorporate DAS (Dynamic Arc Flash Sentry) / Maintenance Mode capability and integrated ZSI (Zone Selective Interlocking)
- Activation of DAS / Maintenance Mode capability requires customer-supplied 24V class II power supply, remote maintenance switch and light
- Trip unit type (Basic or Advanced) is designated in the catalog number as follows:
 - B = Basic – standard ETU (example: SJD6B400LSIG)
 - A = Advanced – ETU with DAS / Maintenance Mode & ZSI (example: SJD6A400LSIG)

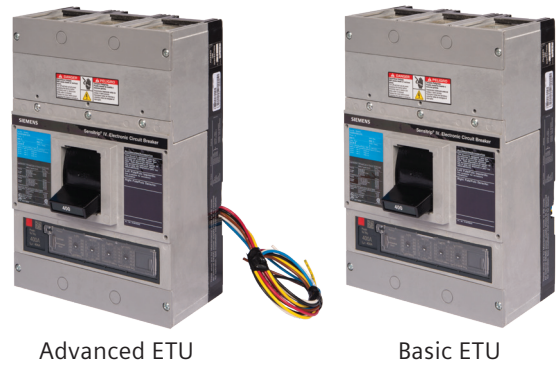

Recommended Components for DAS / Maintenance Mode

Component		Catalog Number
AC/DC Power Supply		6EP3331-6SB00-0AY0
Maintenance Light		3SU1102-6AA50-1AA0
Maintenance Switch	Keyed	3SU1100-4BF11-1BA0
	Non-keyed	3SU1100-2BF60-1BA0

Wiring Diagram for DAS / Maintenance Mode

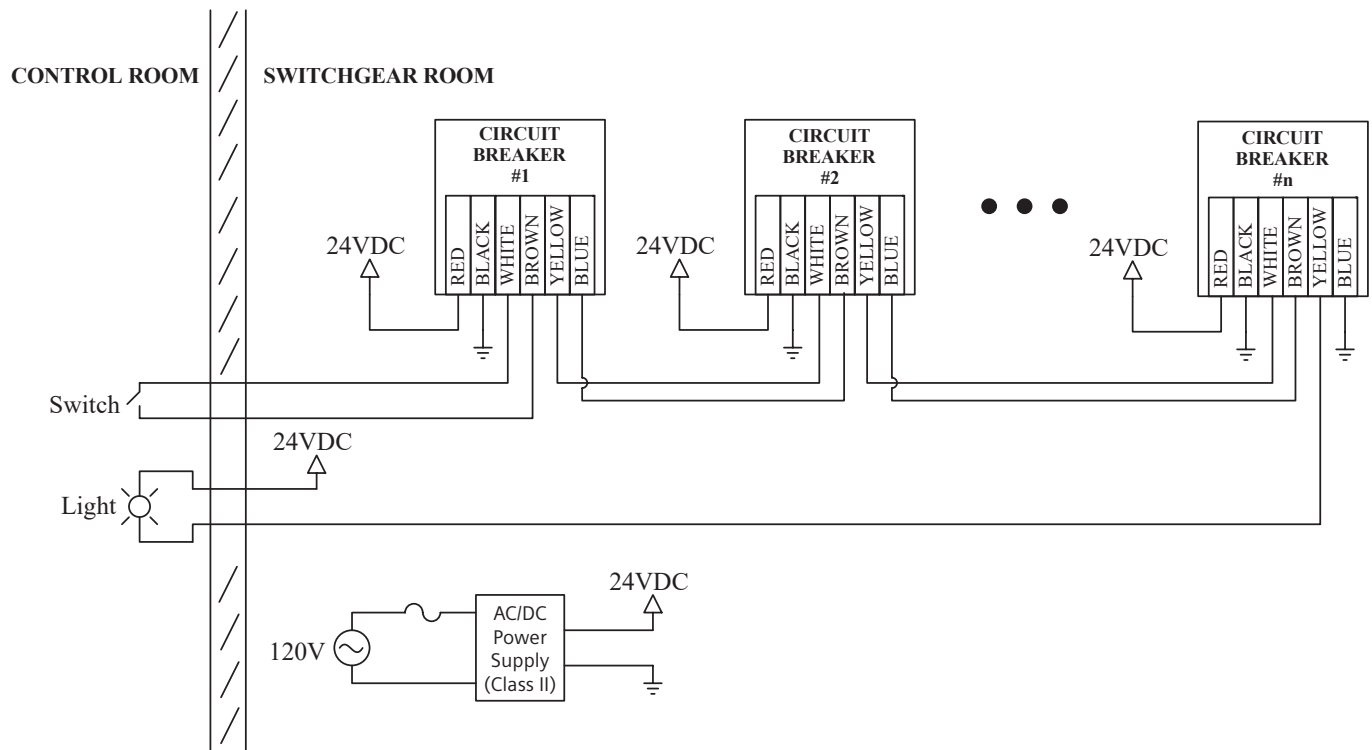

Dimensional Drawing

Sentron Sensitrip IV Outline Drawing

JD and LD Frame Types SJD6-B, SHJD6-B, SLD6-B, SHLD6-B

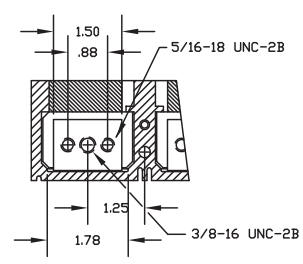
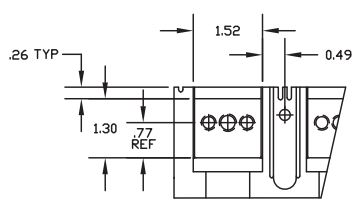
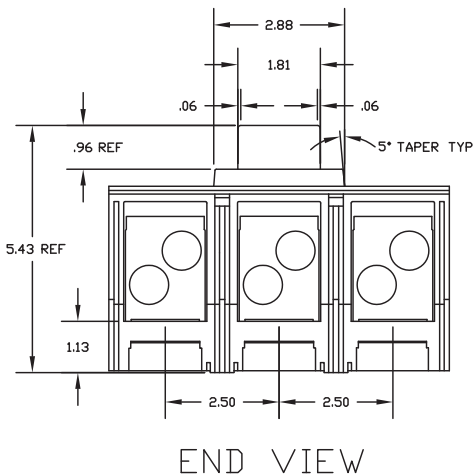
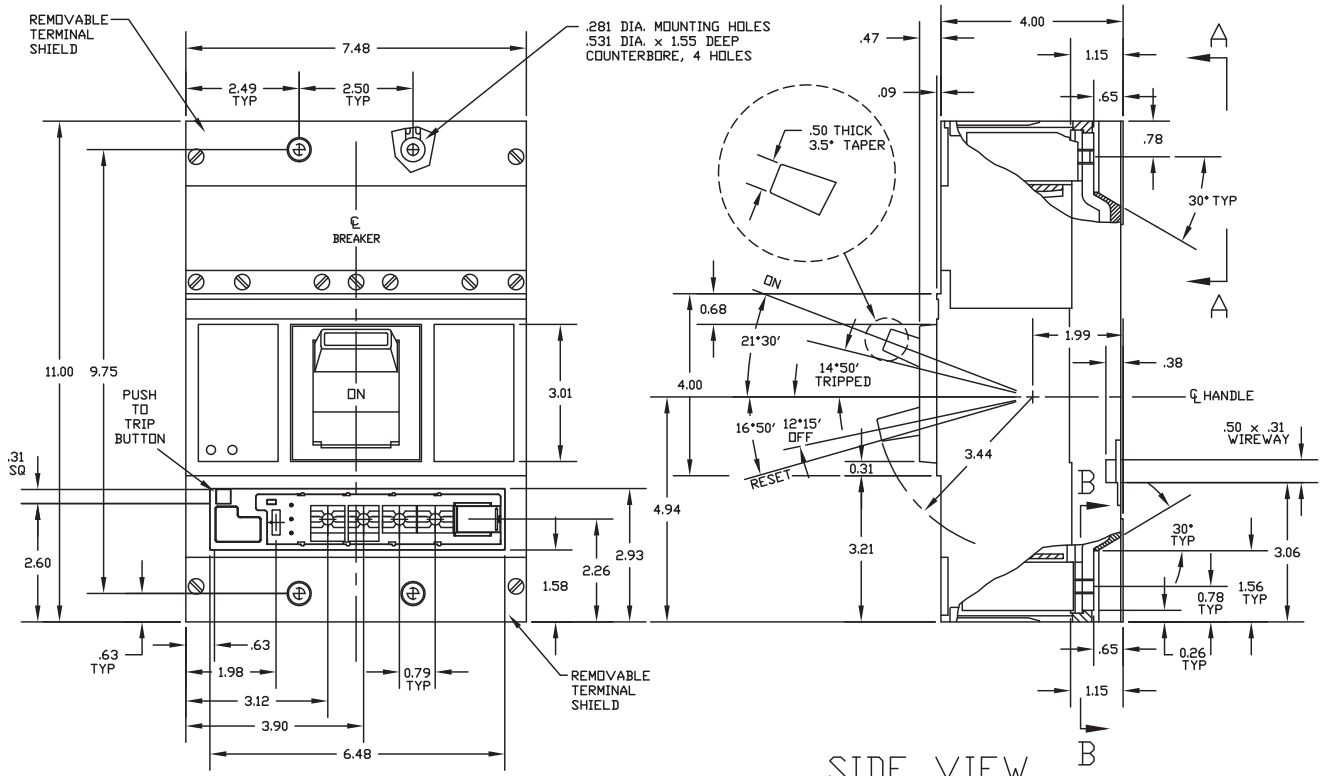

HANDLE OPERATING FORCES		
OPERATION	JD-FRAME (lb.)	LD-FRAME (lb.)
OFF TO ON	44	44
ON TO OFF	50	44
TRIPPED TO RESET	60	60

① All drawing dimensions are shown in inches.

**Published by
Siemens 2018**

Siemens Canada Limited
1577 North Service Rd E
Oakville, ON L6H 0H6

Siemens Customer Interaction Center: 1-800-333-7421
cic.ca@siemens.com

All Rights Reserved
© 2018, Siemens Canada Limited
www.siemens.ca/power distribution

The technical data presented in this document is based on an actual case or on as-designed parameters, and therefore should not be relied upon for any specific application and does not constitute a performance guarantee for any projects. Actual results are dependent on variable conditions. Accordingly, Siemens does not make representations, warranties, or assurances as to the accuracy, currency or completeness of the content contained herein. If requested, we will provide specific technical data or specifications with respect to any customer's particular applications. Our company is constantly involved in engineering and development. For that reason, we reserve the right to modify, at any time, the technology and product specifications contained herein.